



2817 Canal Street
New Orleans, LA 70119

New Orleans Regional Transit Authority Finance Committee

Meeting Agenda - Final-Revised

Thursday, March 13, 2025

11:00 AM

RTA Board Room

The New Orleans Regional Transit Authority (RTA) hereby declares that, in accordance with La. R.S. 42:17.1 (A)(2)(a)-(c), a meeting will be held in person on Thursday, March 13, 2025 at 11:00 a.m. Meetings start at the scheduled time, but may be delayed until a quorum of the Commissioners is present. The agency's website will stream the in-person meeting live, and wearing masks in the boardroom is optional.

Written comments on any matter included on the agenda will be accepted in the following ways: 1) Submission of a Speaker Card on meeting day; 2) Electronically by email sent to: rtaboard@rtaforward.org prior to the meeting; or 3) By U.S. Mail send to 2817 Canal Street, Attention: Office of Board Affairs, New Orleans, LA 70119.

This meeting is accessible to persons with disabilities. To help assure availability, modifications or accommodations linked to a disability must be requested 72 hours before the meeting or hearing. Please direct requests for public meeting accommodations to the Office of Board Affairs, 2817 Canal Street, NOLA 70119, or call 504-827-8341 or by email (rtaboard@rtaforward.org).

1. Call To Order

2. Roll Call

3. Consideration of Meeting Minutes

[Finance Meeting Minutes - February 13, 2025]

[25-029](#)

4. Committee Chairman's Report

5. Chief Executive Officer's Report

6. Chief Financial Officer's Report

7. DBE Report

8. Chief Planning and Capital Project Officer's Report**9. Five Year Capital Improvement Plan**

5-Year Capital Investment Program 2025-2029 [25-027](#)

10. Informational Report

2024 Annual Fare Report [25-025](#)

11. Procurements

A. Authorizations:

Purchase of Canal and Riverfront Streetcar Tires [25-022](#)

Outside Counsel Legal Services [25-024](#)

RTA Insurance Brokerage Services for Property and Casualty Coverages [25-028](#)

B. Amendments:

Change Order Request- Carr, Riggs, & Ingram Contract (RFQ2019-021) [25-023](#)

12. New Business**13. Audience Questions & Comments****14. Adjournment**

[03.13.25 Fin Committee Meeting PowerPoint Presentation] [**25-035**](#)



New Orleans Regional Transit Authority

2817 Canal Street
New Orleans, LA 70119

Board Report and Staff Summary

File #: 25-029

Board of Commissioners

[Finance Meeting Minutes - February 13, 2025]



2817 Canal Street
New Orleans, LA 70119

New Orleans Regional Transit Authority Finance Committee

Meeting Minutes - Draft

Thursday, February 13, 2025

11:00 AM

RTA Board Room

The New Orleans Regional Transit Authority (RTA) hereby declares that, in accordance with La. R.S. 42:17.1 (A)(2)(a)-(c), a meeting will be held in person on Thursday, February 13, 2025 at 11:00 a.m. Meetings start at the scheduled time, but may be delayed until a quorum of the Commissioners is present. The agency's website will stream the in-person meeting live, and wearing masks in the boardroom is optional.

Written comments on any matter included on the agenda will be accepted in the following ways: 1) Submission of a Speaker Card on meeting day; 2) Electronically by email sent to: rtaoard@rtaforward.org prior to the meeting; or 3) By U.S. Mail send to 2817 Canal Street, Attention: Office of Board Affairs, New Orleans, LA 70119.

This meeting is accessible to persons with disabilities. To help assure availability, modifications or accommodations linked to a disability must be requested 72 hours before the meeting or hearing. Please direct requests for public meeting accommodations to the Office of Board Affairs, 2817 Canal Street, NOLA 70119, or call 504-827-8341 or by email (rtaoard@rtaforward.org).

1. Call To Order

2. Roll Call

Commissioners Present: Commissioner Colin, Commissioner Daniels and Commissioner Walton

Commissioner Also Present: Commissioners Sams

3. Consideration of Meeting Minutes (January 9, 2025)

Commissioner Daniels moved and Commissioner Colin seconded to approve the Meeting Minutes of January 9, 2025. The motion was approved unanimously.

4. Committee Chairman's Report

No Report.

5. Chief Executive Officer's Report

The monthly Chief Executive Officer's Report was given. This report can be found in the PowerPoint Presentation for the Finance Meeting.

It was reported that the RTA Lead Group was giving their presentations on February 18, 2025, on problems that they have identified in the agency and solutions to solve these problems. If the Commissioners are not able to attend a video of the presentation can be emailed.

Staff has hired a consultant to help with the recruitment of a Chief of Human Resources Officer. This process should take a total of 90 days. This job will be advertised in all the major trade outlets and staff will make sure that the Board receives a copy of the job description.

The RTA was closing the gap in ridership from the pre COVID numbers.

The process for the Triennial Review has started and this is the second Triennial Review since the RTA became public. The Triennial Review will take place in the summer of 2025.

The RTA was signing the contract with ULU Union. This union is for a select number of administration employees.

6. Chief Financial Officer's Report

The monthly Chief Financial Officer's Report was given. This report can be found in the PowerPoint Presentation for the Finance Meeting.

It was reported that ridership was down by 4.5%, which was less than a half million riders but this does not affect the farebox recovery rate as much as the operating expenses does.

Commissioner Colin asked the team to put an asterisk by the month's payroll is three times a month.

The Youth Fare Program numbers will be reconciled in the budget under Passenger Fares. Commissioner Walton stated that at the end of the Program he would like to use the numbers as a metric. The CEO stated that Ride and the Public Library were responsible for registering the youth for the program and the RTA responsibility was Marketing the program.

Regarding invoices the CFO reported that currently the RTA pays net of 30 and does not have any outstanding invoices.

7. DBE Report

The monthly DBE Report was given. This report can be found in the PowerPoint Presentation for the Finance Meeting.

Commissioner Daniels stated that the RTA has been consistent with Federal Law and he does not think the RTA has to shift how it achieves the excellence in DBE.

8. Chief Planning and Capital Project Officer's Report

The monthly Chief Planning and Capital Project Officer's Report was given. This report can be found in the PowerPoint Presentation for the Finance Meeting.

Commissioner Daniels stated that if any changes occur with the funding for the Capital Projects, please let the Board know as soon as staff become aware.

Commissioner Colin asked that staff create a one-page report for the public outlining the RTA's accomplishments using Federal Funding. The CEO stated the RTA can share the Annual Report with the public that has this information.

The CEO reported that for every \$1.00 spent on a Capital Project it is a \$5.00 return economically.

9. Authorization

Authorization Resolution to file applications with the Federal
Transit Administration

[25-012](#)

Commissioner Daniels moved and Commissioner Colon seconded to approve the Authorization to file Applications with the Federal Transit Administration. The motion was approved unanimously.

Enactment No: 25-012

10. New Business

None.

11. Audience Questions & Comments

None.

12. Adjournment

Commissioner Daniels moved and Commissioner Colin seconded to adjourn the Finance Committee Meeting of February 13, 2025. The meeting was adjourned unanimously.

[02.13.25 Fin PowerPoint]

[25-018](#)



Board Report and Staff Summary

File #: 25-027

Finance Committee

5-Year Capital Investment Program 2025-2029

DESCRIPTION: RTA 5-year Capital Investment Program 2025-29	AGENDA NO: Click or tap here to enter text.
ACTION REQUEST: <input checked="" type="checkbox"/> Approval <input type="checkbox"/> Review Comment <input type="checkbox"/> Information Only <input type="checkbox"/> Other	

RECOMMENDATION:

Authorize the Chief Executive Officer to implement the 5-year Capital Investment Program (CIP) 2025-2029 for the 2025 Calendar Year.

ISSUE/BACKGROUND:

Although the agency has had a long-range, strategic plan, the Strategic Mobility Plan, since 2018 there had been no accompanying formal program of capital projects and initiatives to map out those efforts, their connection to the strategic goals of the agency, budgets, and financing plan. This work is typically accomplished by most public institutions as a Capital Improvement or Investment Program (CIP) with a five (5) year horizon. This timeframe strikes a balance between the long-term maturation of projects, particularly large capital ones, and reasonably predictable financial and tactical forecasting. A CIP does not typically have all funds identified in this 5-year window for all projects but rather sets prioritized guidance for development and pursuit of financing, particularly for projects early in the development stage.

The CIP is also an opportunity to formalize a program of major projects for repair, replacement, and general State of Good Repair (a formal FTA term) of existing vehicles, facilities, rail systems and other assets. The identification of these needs is also being formalized through the Transit Asset Management Plan (TAM), another plan that FTA requires to be updated a minimum of every 4 years and connects to related formula funding for said needs.

In 2023, the Board adopted a 5-year update of the Strategic Mobility Plan to reflect significant changes and accomplishments since 2018. In late 2023, the staff prepared the agency’s first 5-year Capital Investment Program (CIP) to align with this update and its goals, strategies, and actions. The 2024-2028 5-year CIP was introduced to the Board at several meetings (Agenda Item 23-216); however, due to lack of quorum during this time, the item was never fully adopted.

DISCUSSION:

The updated 5-Year Capital Investment Program (CIP) is a 5-year roadmap for 2025 through 2029 that will continue to be updated annually in line with the annual budget process where the next year’s expenditures are fully committed. All local funds in the CY2025 Operating and Capital Budget adopted by the Board in December 2024 for the capital program align with this 5-year CIP. Further

out, a majority of funding in the 5-year CIP is anticipated or projected. By outlining the program first, the CIP serves as a roadmap for securing funding based on strategic priorities including pursuing grants, financing opportunities, and other sources. It is also a means of accountability for the public and the Board to ensure individual activities (e.g. grant applications, new projects) pursued by the staff are in-line with this plan and the agencies strategic priorities.

The 5-year CIP 2025-2029 reflects the need to deliver significant investments in greater transit experience including rapid rides across the region (BRT), faster payment methods, and expanded passenger facilities. This expansion also comes with the need to grow responsibly and maintain current assets and new ones as they come online. The total 5-year CIP program budget is \$627 million. Major projects include the BRT East-West Bank Corridor Project (\$282 million) with the initial project development phase funded but requiring an exploration of bond funding during 2025; the Downtown Transit Center (\$32 million); expansion of passenger facilities through smaller mobility hubs (phase 1, \$10 million); ADA accessible stops for the entire system (\$10 million); and transit priority corridors for bus (\$10.8 million); and developing a roadmap for system streetcar modernization (\$1 million). The 5-year CIP also includes over \$26 million for State-of-Good-Repair projects to maintain and preserve existing assets in good condition.

FINANCIAL IMPACT:

There is no direct financial impact to the agency for the 5-year CIP 2025-2029. Local funds are committed through the annual Operating and Capital Budget. The CIP will guide the pursuit of future funding opportunities such as grants and bond issuance, each of which will align the program budget and plan and will be brought to board as individual actions. The approved CY2025 Operating Budget has local funds for capital expenses totaling \$17.51 million that will be leveraged with a projected \$41.96 million in grant funds based on cash flow projects for the portfolio of projects.

NEXT STEPS:

None.

ATTACHMENTS:

1. Five-Year Capital Investment Program 2025-2029

Prepared By: Dwight Norton
Title: Chief Planning & Capital Projects Officer

Reviewed By: Rafe Rabalais
Title: Director of Capital Projects

Reviewed By: Gizelle Banks
Title: Chief Financial Officer



Lona Edwards Hankins
Chief Executive Officer

3/11/2025

Date



RESOLUTION NO. _____

FILE ID NO 25-027

STATE OF LOUISIANA

PARISH OF ORLEANS

**RESOLUTION TO ADOPT THE 5-YEAR
CAPITAL INVESTMENT PROGRAM (CIP) FOR 2025 THROUGH 2029**

Introduced by Commissioner _____,
seconded by Commissioner _____.

WHEREAS, the New Orleans Regional Transit Authority (RTA) Board of Commissioners adopted a Strategic Mobility Plan in 2018 and a 5-year update in 2023 to define the agency’s long-range, strategic goals with strategies and actions to accomplish these goals; and

WHEREAS, the Capital Investment Program (CIP) is a 5-year roadmap that will be updated annually in-line with the annual budget process where all local funds for the capital program in the approved CY2024 Operating and Capital Budget align with this CIP for 2025-2029; and

WHEREAS, the 5-year CIP 2025-2029 reflects the need to make significant investments in greater transit experience including rapid rides across the region (BRT), faster payment methods, and expanded passenger facilities.

NOW, THEREFORE, BE IT RESOLVED by the Board of Commissioners of the Regional Transit Authority (RTA) that the Chairman of the Board, or their designee, is authorized to implement the 5-year Capital Investment Program 2025-2029 for CY 2025.



Regional Transit Authority
2817 Canal Street
New Orleans, LA 70119-6301

504.827.8300

www.norta.com

Resolution No. _____
Page 2

THE FOREGOING WAS READ IN FULL, THE ROLL WAS CALLED ON THE ADOPTION THEREOF AND RESULTED AS FOLLOWS:

YEAS: _____

NAYS: _____

ABSTAIN: _____

ABSENT: _____

AND THE RESOLUTION WAS ADOPTED ON THE 25th DAY OF MARCH 2025.

FRED A. NEAL, JR.
CHAIRMAN
RTA BOARD OF COMMISSIONERS

NEW ORLEANS REGIONAL TRANSIT AUTHORITY

FIVE-YEAR CAPITAL INVESTMENT PROGRAM

2025 – 2029 DRAFT

February 2025



CONTENTS

1 INTRODUCTION	2
Overview.....	3
Plans → Program → Projects.....	5
Major Funding Sources.....	8
CIP Implementation Process	9
2 PROGRAM DETAILS	10
Major Projects.....	11
All Projects by Category	27

DRAFT

1 | INTRODUCTION

DRAFT

OVERVIEW

One of the RTA’s key roles is to develop and implement a Capital Investment Program (CIP) – in coordination and in alignment with the federal government, the state legislature, the metropolitan planning organization, regional city and parish governments and most importantly the public.

This CIP is a 5-year roadmap that will be updated annually in-line with the annual budget process where the next year’s expenditures are fully committed. A large portion of funding in the 5-year CIP is anticipated or projected. By outlining program first, the CIP serves as a roadmap for securing funding based on strategic priorities including pursuing grants, financing opportunities and other sources.

The CIP 2025-2029 reflects the need to make significant investments in greater transit experience including rapid rides across the region (BRT), faster payment methods, and expanded passenger facilities. This expansion also comes with need to grow responsibly and maintain current assets and new ones as they come online.

The investments described in this plan are capital expenditures organized into the following categories:

- **State of Good Repair:** Investments in end-of-life asset replacement needs
- **Fleet:** The replacement and addition vehicles for all modes is critical to RTA’s needs to maintain and provide reliable service.
- **Facilities:** RTA has several facilities that support operational needs, but is building out a first-ever program of facilities for passengers over the next five years.
- **Fixed-Guideway:** Includes modernization and development of rail (streetcar), dedicated busways, and bus rapid transit (BRT)
- **Technology:** Modernizing and integrating RTA’s software and hardware systems continues to be a critical need.
- **Marine:** Investments in ferry service, fleet and facilities.

The CIP also includes a number of specific plans and studies identified as essential next steps prior developing projects for evaluation and inclusion in future versions of this CIP.

Key Administrative Activities for 2025:

- Onboard a Program Management Consultant (PMC) to assist in program administration and major projects management
- Support Asset Management to complete condition assessments on all RTA facilities and rail systems
- Transition CIP into RTA’s budgeting software, launched in 2024
- Update Project Manager Manual to reflect new software and procedures
- Develop a Capital Program policy for Board adoption to set guidance on funding goals, spending allowances and reporting requirements
- Explore a Capital reserve account to even out local funds over time
- Initiate bonding capacity research

Program Investments By Category

The graphs below provide an overview of project costs by category and the overall funding sources for the program over the next 5 years. Details on CIP projects are in the next section.

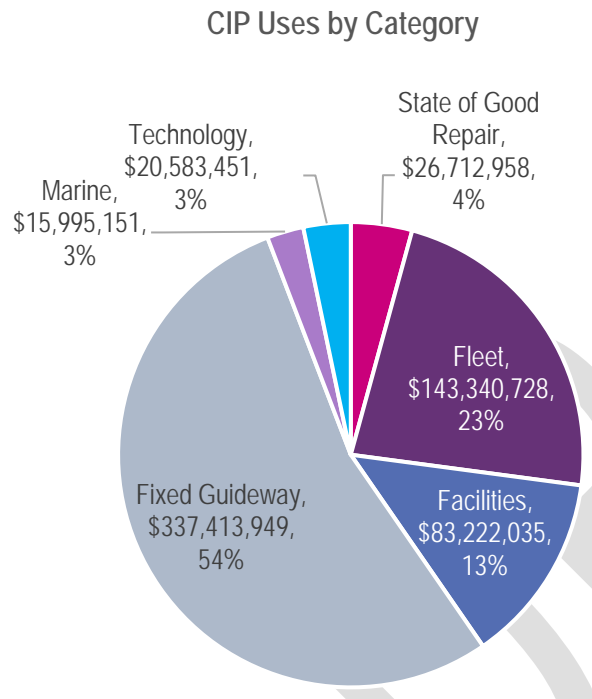

Note: Fixed Guideway includes \$282 million for Bus Rapid Transit (BRT) East-West Bank

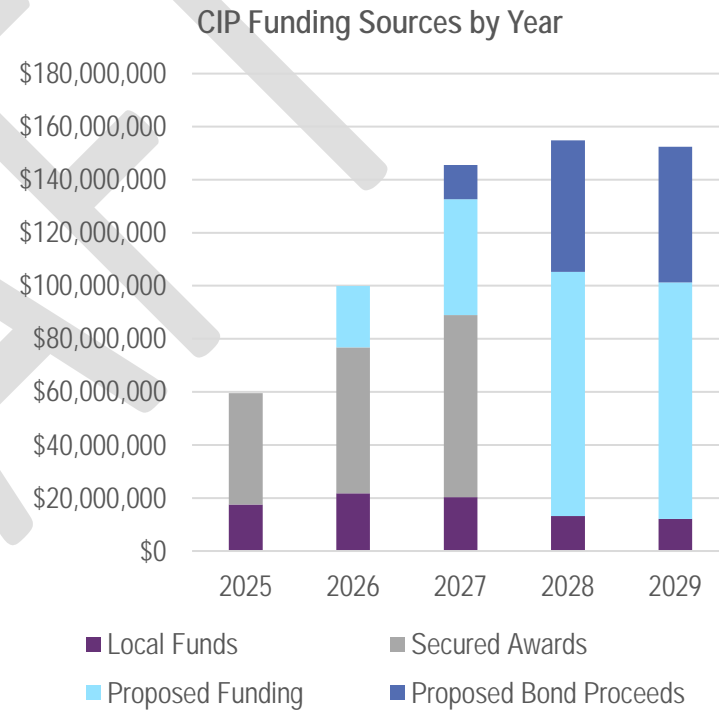

PLANS 🕒 PROGRAM 🕒 PROJECTS

This CIP continues to be informed by two major plans: the Strategic Mobility Plan and the Transit Asset Management Plan.

The **Strategic Mobility Plan (SMP)** is a strategic vision directed by public and stakeholder input collected throughout the original development process in 2018 and the recent 2023 update. RTA organizational priorities are built around funding programs within which projects are selected based on objective and comparative evaluation that meet the goals and strategies identified in the SMP. Some of the specific actions in the SMP are specific plans and studies as a necessary first step to further understand a need or challenge and develop solutions that may include detailed projects for evaluation into the CIP.

The **Transit Asset Management Plan (TAM)** is a federally required plan that is updated at minimum every four years, most recently in 2023. The TAM includes condition assessments on all systems including fleet, rail, power systems, and facilities. Based on the expended useful life of each of the components and their current assessment rating, a program of improvements are developed for maintaining RTA assets in a "State of Good Repair" (SGR). Projects are then connected to grants from FTA dedicated to SOGR. Improvements that are of significant size or effort are considered capital projects. A key activity by the Capital Projects department and Asset Management Division will be complete updated condition assessments on all facilities and rail systems in 2025 inform future projects to ensure basic systems are maintained and in good working order.

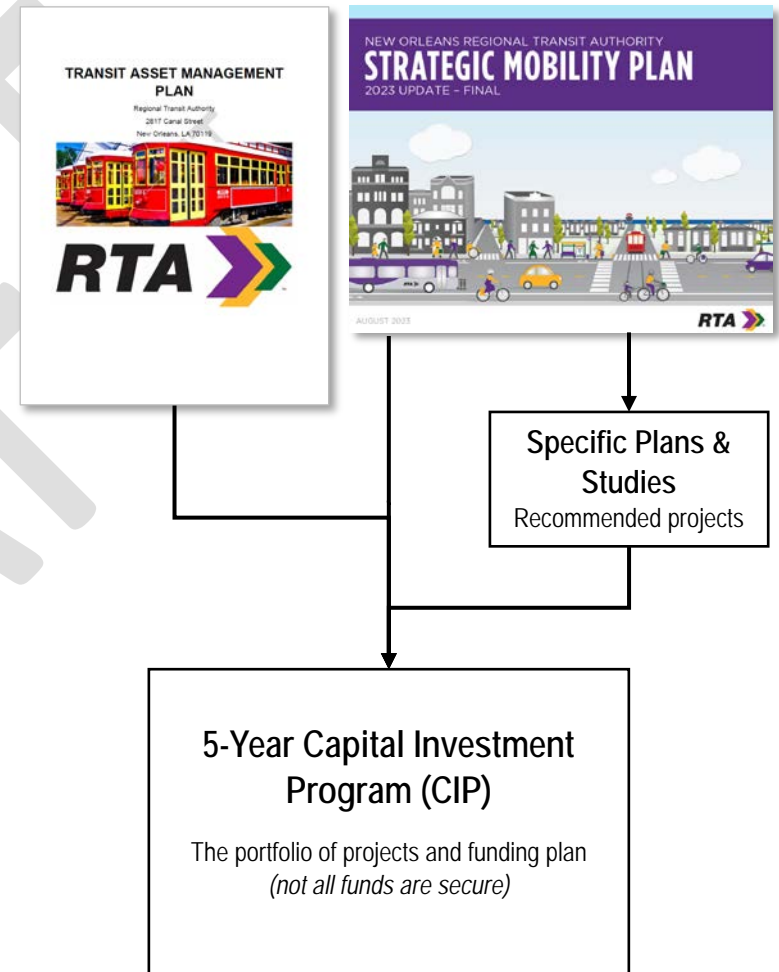

Progress on SMP Implementation Priorities

The following summary from the SMP 2023 Update highlights key activities that directly inform direction for investment and current status on implementation progress.

STRENGTHEN THE FOUNDATION (2 YEARS)

BUILD THE SYSTEM (5 YEARS)

By 2025...			By 2028...		
ACTIVITY	STATUS	PROGRESS	ACTIVITY	STATUS	PROGRESS
Improve public information and customer service	●	New see-say launched New alert tools in development	Construct Bus Rapid Transit corridor connecting New Orleans East to West Bank	●	Design starting in 2025; target launch 2029
Improve transit stops through stop rebalancing and expanding stop amenities including benches, shelters, art, and information	●	Stops inventory underway	Begin introducing new service types, including Bus Rapid Transit, High-Capacity Transit, Select Service, and regional express service	●	Planning underway
Speed up travel times by offering more pay-before-boarding fare media options	●	Fare technology RFP to release in 2025	Speed up travel times and improve on-time performance by adding dedicated transit lanes, signal priority improvements, and other transit priority treatments	●	Transit priority corridor inhouse assessment underway
Increase reliability with study and plan for transit priority elements, such as traffic signal priority, dedicated lanes	●	Inhouse analysis framework started	Construct transit centers in Downtown, New Orleans East, and Algiers and smaller hubs at major transfer points	●	\$46 million secured for transit centers; Design to begin in 2025
Introduce and expand low- or no-emission vehicles into the fleet	●	14 hybrid buses in service Batter electric buses will be ordered in 2025	Improve ADA accessibility of service, including making all transit stops ADA accessible by 2030	●	Accessibility study underway; Awarded \$6.9M for ADA streetcar stops
Pilot emerging mobility options	●	Procurement of software for on-demand underway	Identify and secure additional funding sources	●	In development
			Introduce streetcar corridor modernization to enable faster safer and more accessible streetcar service	●	Streetcar Modernization master plan to start in 2025

LEGEND:

● On pace ● Getting on track ● Behind schedule

Investment Priorities

The three priorities for new CIP are, in order of importance: Reliability, Modernization, and Expansion. These priorities express the broadest goals for RTA investments.

Reliability

Maintain and improve the overall condition, safety and reliability of the transportation system. (10% of all investments, without BRT increases to 18%)

- Necessary routine and capital maintenance and ensuring safety of the system
- State of good repair projects designed primarily to bring asset condition up to an acceptable level
- Asset management and system preservation projects

Modernization

Modernize the transportation system to make it safer, more accessible, more resilient, more sustainable and accommodate growth. (29% of all investments)

- Compliance with federal mandates or other statutory requirements for safety and/or accessibility improvements
- Projects that go beyond state of good repair and substantially modernize existing assets, including for resilience and sustainability benefits
- Projects that result in improved performance and quality of transit service (e.g. transit priority treatments)

Expansion

Expand diverse transportation options for communities throughout the region. (61% of all investments - without BRT, drops to 31%)

- Projects that introduce new modes of service
- Projects that expand fixed-guideway (BRT, streetcar and dedicated busways) network and/or services
- Projects that expand passenger and operations facilities

The remaining investments support plans and studies necessary to further develop future service, programs and projects.

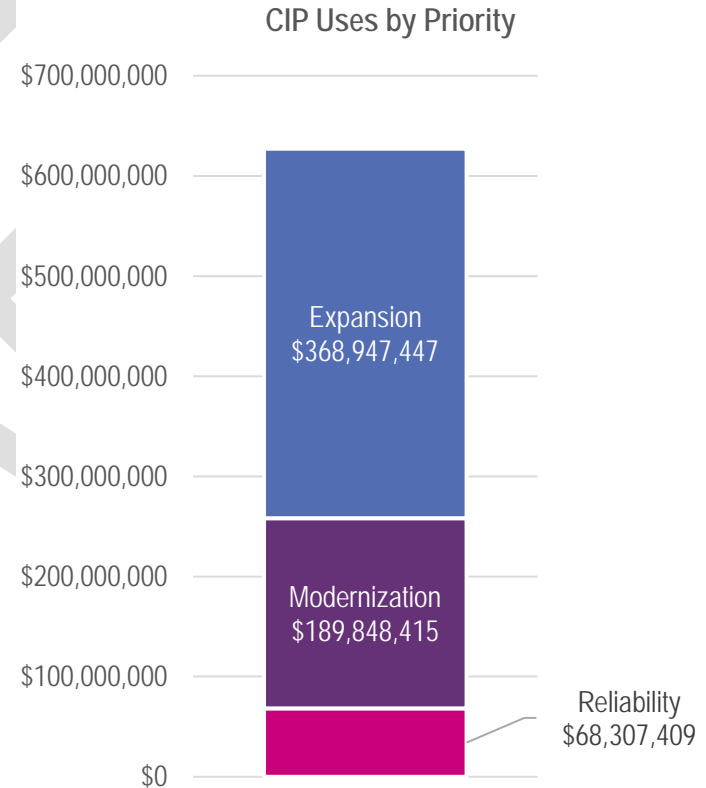

Note: Expansion includes \$282 million for Bus Rapid Transit (BRT) East-West Bank Corridor

MAJOR FUNDING SOURCES

RTA General Fund

A portion RTA's annual budget includes funds dedicated to the capital program. This annual allocation includes matching funds for grants and other direct local funding for projects.

Federal Transit Administration (FTA)

FTA is the primary sponsor of the majority of RTA's capital program and State of Good Repair (SOGR) projects. This funding category is a mix of formula funding grants and competitive grants the agency involves RTA drawing down obligated amounts to reimburse project spending. The spending by source tables do not include FTA funds available to Regional Transit Authority partners.

Bonds

RTA has full authority to issue revenue bonds. Bonds are historically backed by a portion of the agency's sales tax revenue. The agency has two bond issues that were refinancing of early bond issues, most recently for streetcar expansion, and have a repayment balance of \$101 million with debt service payments through 2036.

A new bond issue is central to the funding strategy for BRT East-West Bank corridor project.

State of Louisiana

There are several funding sources from the State of Louisiana for the CIP. One of the main ones includes the State Capital Outlay

which entities submit request for project for review and evaluation annually for funding. The state also has several state highway improvement programs for rehabilitation, safety and other enhancement. Historically, RTA has not received significant capital funding from the State.

Other and Emerging Sources

Several other federal opportunities exist such as from U.S. DOT for general transportation opportunities and FEMA for disaster recovery and hazard mitigation. RTA has also partnered with other government entities for joint investments including the City of New Orleans and other local entities.

Undeveloped sources include value capture opportunities such as through tax-increment financing (TIF) or infrastructure improvement districts. Property-based value capture is needed to fund infrastructure due to its higher revenue and direct benefit potential to real-estate development. Due to a heavily restricted property millage, the New Orleans region has historically only used sale-tax based TIFs.

Newer financing opportunities in development include emerging products from Finance New Orleans for low-interest loans to enhance infrastructure resilience and expanded eligibility for projects from the U.S. Transportation Infrastructure Finance and Innovation Act (TIFIA) loan program.

CIP IMPLEMENTATION PROCESS

With this program of projects identified in the next section, funding needs that are not already secured are reviewed and refined on an annual basis. Funding needs then inform a strategy that includes identification and pursuit of grant funding, other 3rd party sources such as governmental partnerships, financing opportunities and local funding. Secured funding is finalized through the annual budget process for the next year. All projects for 2024 are fully funded. The chart at right illustrates the process.

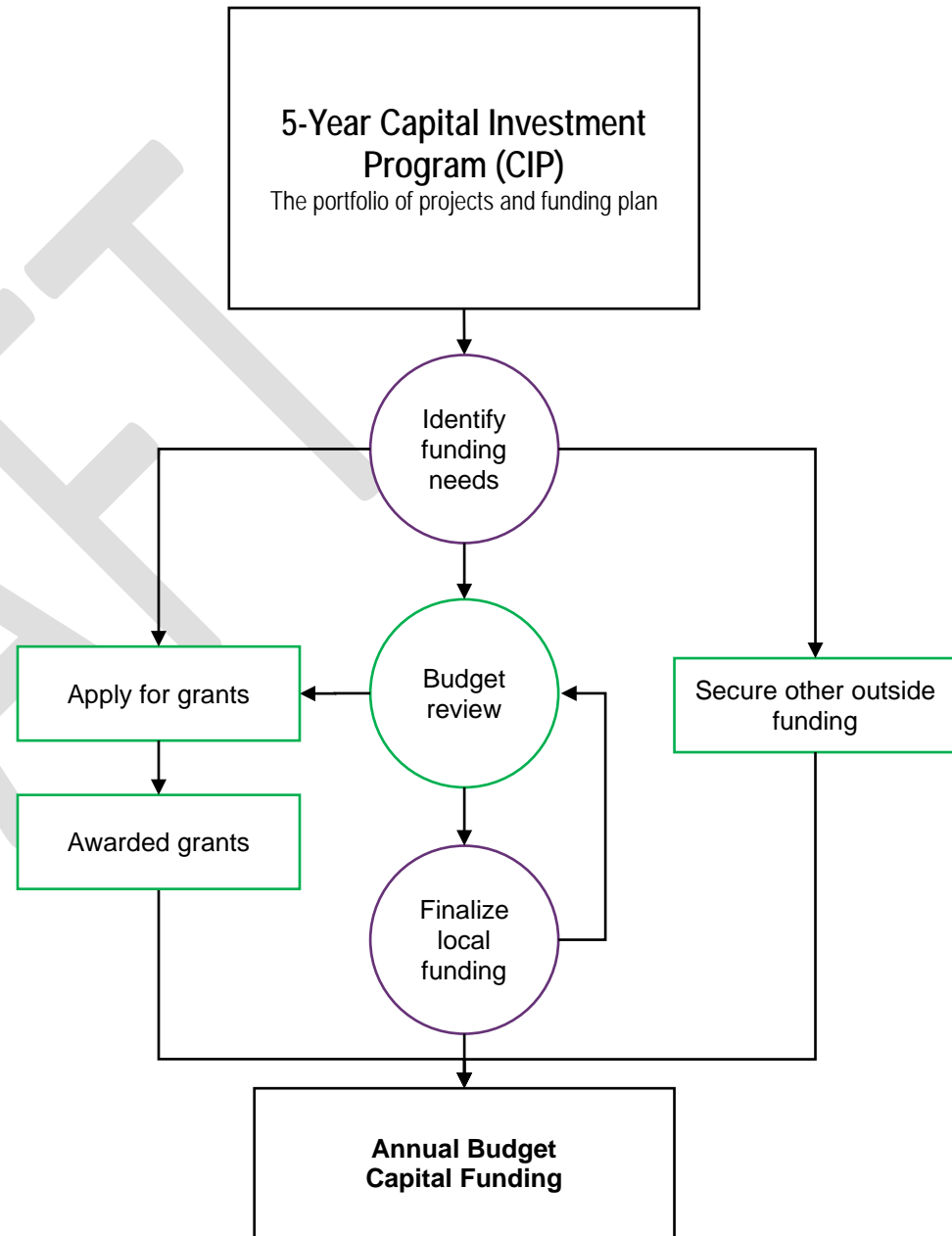

2 | PROGRAM DETAILS

DRAFT

MAJOR PROJECTS

This section includes funding details for selected strategically significant projects in the CIP. Remaining projects listed in the next section.

The most significant project, as measured by cost and beneficial impact, is the Bus Rapid Transit (BRT) East-West Bank Corridor. The current financing plan is based on the project's Feasibility Study which was concluded in late 2023.

All amounts shown are in 2023 dollars and not adjusted for year-of-expenditure; however, all budgets do include progressive contingencies based on the duration of the project.

DRAFT

Algiers Ferry Buildings Renovation

Renovation of the Algiers Point Ferry Terminal and improvement to surrounding areas and access, and renovate Maintenance Facility

Project #: 2019-MA-01

SMP Action: UP4

Project Category: FA - Facilities

Project Type: Modernization

Project Status: Construction starting mid-2025

Project Budget:

Task	Amount
Administration (internal)	\$218,919
Planning/Study	\$0
PM/CM (3rd party)	\$0
Design/Engineering	\$1,100,000
Construction	\$8,220,617
Equipment/Materials	\$150,000
Vehicles	\$0
Other	\$0
Total	\$9,689,536



Project Funding Sources:

Source	Total Cost	pre-2025	2025	2026	2027	2028	2029
RTA Local Funds	\$1,879,708	\$120,437	\$1,231,766	\$527,505			
Secured Grants/Other Sources	\$7,809,828	\$481,750	\$5,218,060	\$2,110,019			
Proposed Grants/Other Sources	\$0	\$0	\$0	\$0			
Total	\$9,689,536	\$602,187	\$6,449,826	\$2,637,523			

Carrollton Double Crossover Replacement

Replacement of special trackwork at the end of the St Charles streetcar route on Carrollton Av to improve safety and reliability.

Project #: 2019-FG-01 SMP Action: TAM
 Category: SGR – State of Good Repair Type: Reliability

Project Status: Construction starting mid-2025

Project Budget:

Task	Amount
Administration (internal)	\$0
Planning/Study	\$0
PM/CM (3rd party)	\$0
Design/Engineering	\$109,800
Construction	\$2,899,634
Equipment/Materials	\$1,294,680
Vehicles	\$0
Other	\$0
Total	\$4,304,114



Project Funding Sources:

Source	Total Cost	pre-2025	2025	2026	2027	2028	2029
RTA Local Funds	\$ 860,823	\$460,823	\$400,000				
Secured Grants/Other Sources	\$3,443,291	\$1,843,291	\$1,600,000				
Proposed Grants/Other Sources	\$0		\$0				
Total	\$4,304,114	\$2,304,114	\$2,000,000				

Algiers Ferry Barges Replacement

Replace landing barges at Algiers Point and Lower Algiers with new, standardized design for interoperability between ferry landing locations.

Project #: 2022-MA-01
Project Category: MA - Marine

SMP Action: UP4
Project Type: Modernization

Project Status: In Design; Construction start late 2025

Project Budget:

Task	Amount
Administration (internal)	\$212,387
Planning/Study	\$0
PM/CM (3rd party)	\$0
Design/Engineering	\$1,093,558
Construction	\$12,364,206
Equipment/Materials	\$0
Vehicles	\$0
Other	\$0
Total	\$13,670,151



Project Funding Sources:

Source	Total Cost	2025	2026	2027	2028	2029
RTA Local Funds	\$2,734,033	\$2,075,089	\$518,772			
Secured Grants/Other Sources	\$10,936,117	\$8,300,354	\$2,075,089			
Proposed Grants/Other Sources	\$0	\$0	\$0			
Total	\$13,670,151	\$901,803	\$4,058,114			

Downtown Transit Center

Programming, design and construction of the Downtown Transit Center as the main transfer point between local bus service in neutral ground of Basin St at Canal St with connections to streetcars and future Bus Rapid Transit. Project includes improving corridor along Loyla/Basin St to improve safety and comfort for all users including transit, bicycling and walking.

Project #: 2015-FA-01
 Project Category: FA - Facilities

SMP Action: PR21
 Project Type: Expansion

Project Status: Design starting mid-2025

Project Budget:

Task	Amount
Administration (internal)	\$132,061
Planning/Study	\$0
PM/CM (3rd party)	\$235,824
Design/Engineering	\$4,003,692
Construction	\$28,662,054
Equipment/Materials	\$0
Vehicles	\$0
Other	\$0
Total	\$33,033,631



Project Funding Sources:

Source	Total Cost	2025	2026	2027	2028	2029
RTA Local Funds	\$6,737,075	\$370,221	\$1,425,307	\$4,940,585		
Secured Grants/Other Sources	\$26,296,557	\$1,445,069	\$5,563,343	\$19,284,390		
Proposed Grants/Other Sources						
Total	\$33,033,632	\$1,815,290	\$6,988,650	\$24,224,976		

BRT East-West Bank Corridor

Bus Rapid Transit (BRT) linking New Orleans East and Algiers to downtown through 13.5 mile alignment over 50% in dedicated lanes and other transit priority along 15 stations spaced 1/2 - 1 mile apart.

Project #: 2021-FG-01
Category: FG - Fixed Guideway

SMP Action: CO3
Type: Expansion



Project Status: Design starting mid-2025

Project Budget:

Task	Amount
Administration (internal)	\$0
Planning/Study	\$599,949
PM/CM (3rd party)	\$20,760,000
Design/Engineering	\$26,814,000
Construction	\$194,000,000
Equipment/Materials	\$0
Vehicles	\$39,000,000
Other	\$0
Total	\$282,473,949

Project Funding Sources:

Source	Total Cost	2025	2026	2027	2028	2029
RTA Local Funds	\$20,037,000	0	\$486,021	\$2,187,797	\$8,751,187	\$8,611,996
Secured Grants/Other Sources	\$7,500,000	\$3,000,000	\$4,500,000	\$0	\$0	\$0
Proposed Grants/Other Sources*	\$140,836,999	0	\$512,590	\$15,377,687	\$61,510,750	\$63,435,973
Proposed Bond Proceeds	\$113,881,877	0	\$0	\$12,805,914	\$49,571,278	\$51,122,808
Total	\$282,473,949	\$3,000,000	\$5,498,610	\$30,371,398	\$119,833,215	\$123,170,778

* Includes \$120 million federal CIG grant (50% cap) and \$20.7 million mix of other state/city funds

St Charles Loop Replacement, Phase 4

Replacement of end-of-life trackwork around Harmony Circle and adjacent segments on the the St Charles streetcar route in downtown to improve safety and reliability.

Project #: 2023-FG-01 SMP Action: TAM
Category: SGR – State of Good Repair Type: Reliability

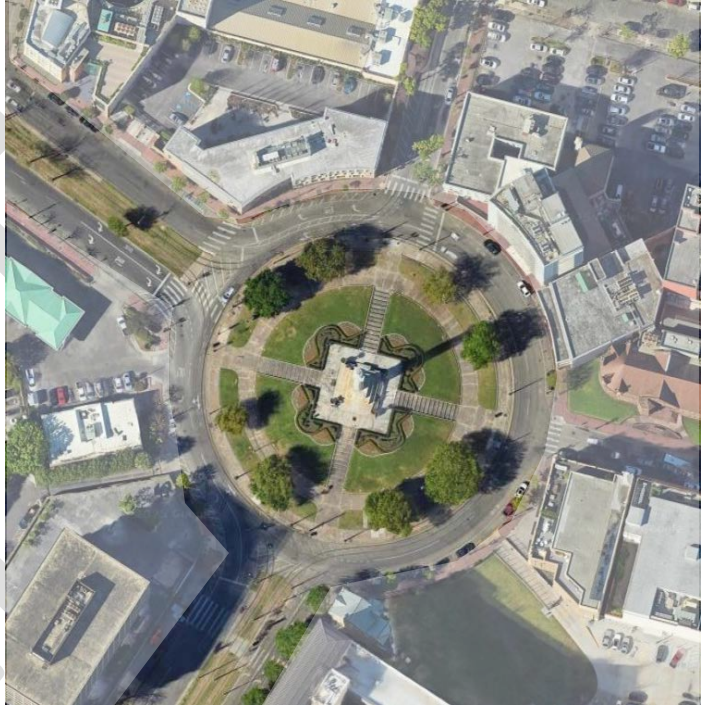

Project Status: Design starting mid-2025

Project Budget:

Task	Amount
Administration (internal)	\$0
Planning/Study	\$0
PM/CM (3rd party)	\$600,000
Design/Engineering	\$1,400,000
Construction	\$5,500,000
Equipment/Materials	\$5,000,000
Vehicles	\$0
Other	\$0
Total	\$12,500,000

Project Funding Sources:

Source	Total Cost	2025	2026	2027	2028	2029
RTA Local Funds	\$5,483,520	\$1,368,765	\$4,114,755			
Secured Grants/Other Sources	\$3,280,000	\$818,735	\$2,461,265			
Proposed Grants/Other Sources	\$3,736,480	\$0	\$3,736,480			
Total	\$12,500,000	\$2,187,500	\$10,312,500			

UPT Admin Office Renovation

Design and construction of administrative offices at the Union Passenger Terminal 2nd Floor

Project #: 2022-FA-01
Project Category: FA - Facilities

SMP Action: UP3
Project Type: Modernization

Project Status: Design start in Q2 2025

Project Budget:

Task	Amount
Administration (internal)	\$100,000
Planning/Study	\$100,000
PM/CM (3rd party)	\$0
Design/Engineering	\$240,000
Construction	\$4,560,000
Equipment/Materials	\$0
Vehicles	\$0
Other	\$0
Total	\$5,000,000



Project Funding Sources:

Source	Total Cost	2025	2026	2027	2028	2029
RTA Local Funds	\$1,000,000	\$523,733	\$476,267			
Secured Grants/Other Sources	\$4,000,000	\$2,094,933	\$1,905,067			
Proposed Grants/Other Sources	\$0					
Total	\$5,000,000	\$2,618,667	\$2,381,333			

Comprehensive Fare Modernization Initiative

Introduce re-chargable tap cards and other modern fare collection technologies to reduce boarding times, lower maintenance costs and increase fare recovery rate.

Project #: 2022-IT-02

SMP Action: PR4

Project Category: IT - Technology

Project Type: Modernization

Project Status: In Planning; Design starts late 2025

Project Budget:

Task	Amount
Administration (internal)	\$0
Planning/Study	\$561,588
PM/CM (3rd party)	\$0
Design/Engineering	\$850,000
Construction	\$0
Equipment/Materials	\$7,225,000
Vehicles	\$0
Other	\$0
Total	\$8,636,588

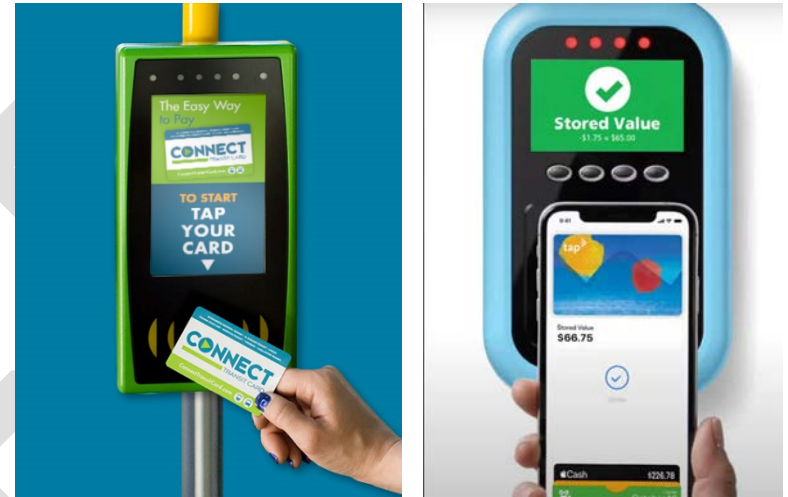

Project Funding Sources:

Source	Total Cost	2025	2026	2027	2028	2029
RTA Local Funds	\$1,727,318	\$277,318	\$1,450,000			
Secured Grants/Other Sources	\$6,909,270	\$1,109,270	\$5,800,000			
Proposed Grants/Other Sources						
Total	\$8,636,588	\$1,386,588	\$7,250,000			

Mobility Hubs, Phase 1

Design of six transfer hubs as recommended by Mobility Hub Study (2023-PS-01) and construction of 2-4 based on available funds; design of new transit shelter is include throughout locations

Project #: 2024-FA-04
Project Category: FA - Facilities

SMP Action: PR23
Project Type: Expansion

Project Status: Design starts mid-2025

Project Budget:

Task	Amount
Administration (internal)	\$325,000
Planning/Study	\$0
PM/CM (3rd party)	\$0
Design/Engineering	\$1,960,000
Construction	\$11,045,000
Equipment/Materials	\$0
Vehicles	\$0
Other	\$500,000
Total	\$13,830,000

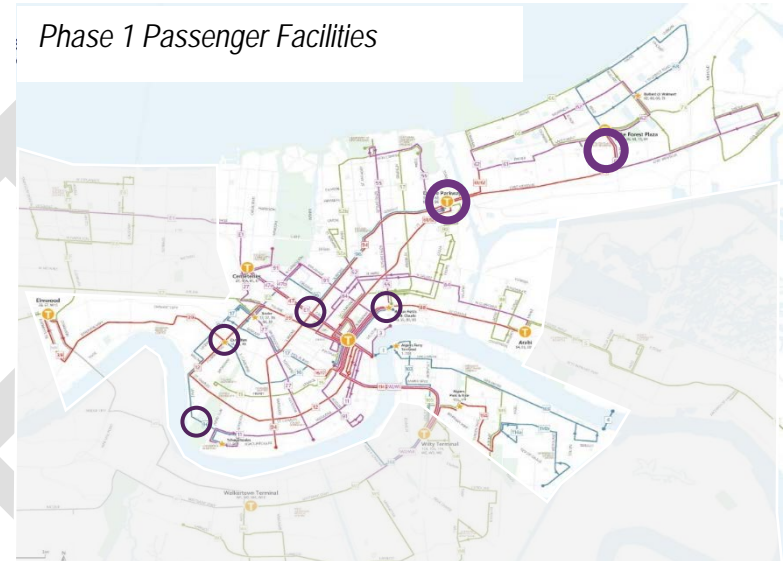

Project Funding Sources:

Source	Total Cost	2025	2026	2027	2028	2029
RTA Local Funds	\$2,766,000	\$284,965	\$1,862,207	\$598,414		
Secured Grants/Other Sources	\$11,064,000	\$1,139,859	\$7,448,829	\$2,393,657		
Proposed Grants/Other Sources	\$0	\$0	\$0	\$0		
Total	\$13,830,000	\$1,424,824	\$9,311,036	\$2,992,071		

Zero-Emission, Resilient Fleet

This transformational initiative will build on RTA's zero-emission pilot with 20 additional battery-electric buses, in-route charging infrastructure, and a 5MW solar-powered backup charging system. The project also include significant workforce development

Project #: 2023-FL-02

SMP Action: BR28

Project Category: FL - Fleet

Project Type: Modernization



Project Status: In Planning; Design starts Q2 2025

Project Budget:

Task	Amount
Administration (internal)	\$0
Planning/Study	\$120,000
PM/CM (3rd party)	\$731,000
Design/Engineering	\$0
Construction	\$13,586,879
Equipment/Materials	\$31,702,718
Vehicles	\$31,283,086
Other	\$4,500,000
Total	\$81,923,684



Project Funding Sources:

Source	Total Cost	2025	2026	2027	2028	2029
RTA Local Funds	\$10,434,600	\$1,612,250	\$2,510,917	\$6,261,433		
Secured Grants/Other Sources	\$71,539,114	\$10,395,020	\$17,501,323	\$43,642,772		
Proposed Grants/Other Sources						
Total	\$81,973,714	\$12,007,270	\$20,012,239	\$49,904,205		

All Stops Accessible Program, St Charles

Upgrade 40 stops along St Charles Streetcar route to be ADA compliant and consolidate several redundant stops to achieve full accessible stops.

Project #: 2023-FL-04
Category: FA - Facilities

SMP Action: BE7
Type: Modernization



Project Status: Design starts mid-2025

Project Budget:

Task	Amount
Administration (internal)	\$149,363
Planning/Study	\$217,182
PM/CM (3rd party)	\$398,302
Design/Engineering	\$497,878
Construction	\$5,602,931
Equipment/Materials	\$0
Vehicles	\$0
Other	\$0
Total	\$6,865,656

Project Funding Sources:

Source	Total Cost	2025	2026	2027	2028	2029
RTA Local Funds	\$1,373,131	\$100,000	\$400,000	\$873,131		
Secured Grants/Other Sources	\$5,492,525	\$400,000	\$1,600,000	\$3,492,525		
Proposed Grants/Other Sources	\$0					
Total	\$6,865,656	\$500,000	\$2,000,000	\$4,365,656		

Streetcar System Modernization

Modernize the streetcar system including, guideways, power systems and vehicles, to develop a safer and fully accessible system to improve speed and rider convenience.

Project #: CIP-2023-05

SMP Action: UP2

Project Category: FG - Fixed Guideway

Project Type: Modernization

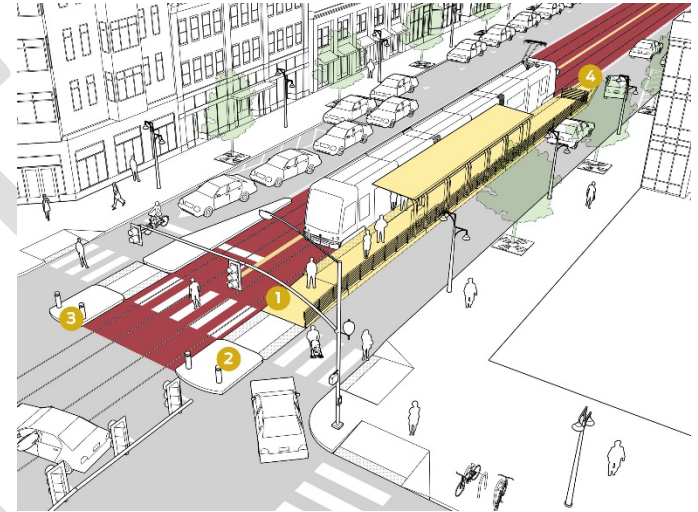

Project Status: Master Planning starts mid-2025

Project Budget:

Task	Amount
Administration (internal)	\$0
Planning/Study	\$1,000,000
PM/CM (3rd party)	\$0
Design/Engineering	TBD
Construction	TBD
Equipment/Materials	TBD
Vehicles	TBD
Other	\$0
Total	TBD

Project Funding Sources:

Source	Total Cost	2025	2026	2027	2028	2029
RTA Local Funds	\$250,000	\$100,000	\$150,000			
Secured Grants/Other Sources	\$750,000	\$250,000	\$500,000			
Proposed Grants/Other Sources	\$0	\$0	\$0			
Total	\$1,000,000	\$250,000	\$500,000	TBD	TBD	TBD

Note: Specific projects and associated costs will be identified through the master planning process

Select Bus Corridor Improvements

Safety, stops, and transit priority improvements to high-frequency bus corridors to increase speed, reliability and comfort

Project #: CIP-2023-06

SMP Action: CO1

Project Category: FG - Fixed Guideway

Project Type: Modernization

Project Status: Feasibility study starts late 2025

Project Budget:

Task	Amount
Administration (internal)	\$537,500
Planning/Study	\$0
PM/CM (3rd party)	\$0
Design/Engineering	\$1,075,000
Construction	\$6,987,500
Equipment/Materials	\$2,150,000
Vehicles	\$0
Other	\$0
Total	\$10,750,000

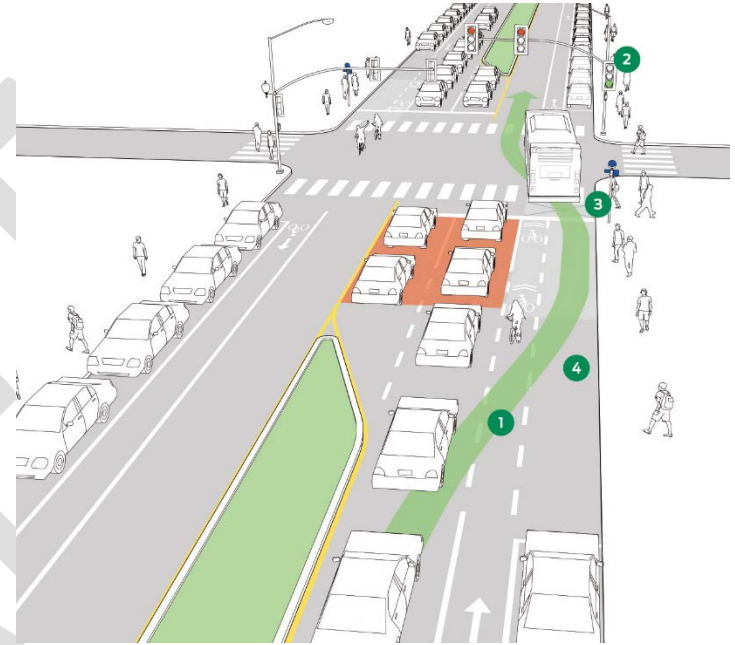

Project Funding Sources:

Source	Total Cost	2025	2026	2027	2028	2029
RTA Local Funds		\$0	\$0	\$0	\$1,000,000	\$1,000,000
Secured Grants/Other Sources		\$200,000	\$550,000	\$0	\$0	\$0
Proposed Grants/Other Sources		\$0	\$0	\$0	\$4,000,000	\$4,000,000
Total	\$10,750,000	\$550,000	\$5,200,000	\$0	\$5,000,000	\$0

Uptown-Downtown Streetcar Connector (Howard Av)

Extend streetcar track 0.2 miles from Loyola Av down Howard Av 2.5 blocks to connect to St Charles line with complete street elements and redesign Julia St Station

Project #: CIP-2016-01

SMP Action: UP2

Project Category: FG - Fixed Guideway

Project Type: Expansion

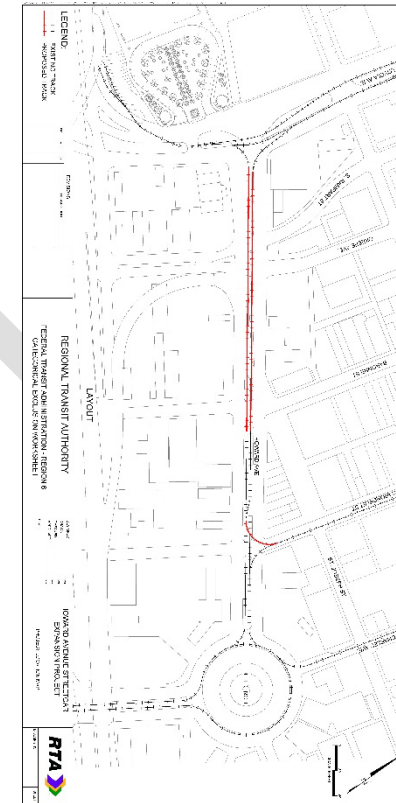

Project Status: In Planning

Project Budget:

Task	Amount
Administration (internal)	\$500,000
Planning/Study	\$0
PM/CM (3rd party)	\$0
Design/Engineering	\$1,000,000
Construction	\$6,000,000
Equipment/Materials	\$2,500,000
Vehicles	\$0
Other	\$0
Total	\$10,000,000

Project Funding Sources:

Source	Total Cost	2025	2026	2027	2028	2029
RTA Local Funds	\$0	\$0	\$500,000	\$0	\$0	\$0
Secured Grants/Other Sources	\$0	\$0	\$0	\$0	\$0	\$0
Proposed Grants/Other Sources	\$9,500,000	\$0	\$0	\$4,500,000	\$5,000,000	\$0
Total	\$10,000,000	\$0	\$1,000,000	\$4,000,000	\$5,000,000	\$0

Riverfront Streetcar Extention

Extension of Riverfront Streetcar 0.7 miles into River District with addition of two-three stops including multimodal transti stop intersecting with BRT

Project #: CIP-2023-04

SMP Action: UP2

Project Category: FG - Fixed Guideway

Project Type: Expansion

Project Status: In Planning

Project Budget:

Task	Amount
Administration (internal)	\$900,000
Planning/Study	\$0
PM/CM (3rd party)	\$0
Design/Engineering	\$1,800,000
Construction	\$9,000,000
Equipment/Materials	\$6,300,000
Vehicles	\$0
Other	\$0
Total	\$18,000,000



Project Funding Sources:

Source	Total Cost	2025	2026	2027	2028	2029
RTA Local Funds	\$0	\$0	\$0	\$0	\$0	\$0
Secured Grants/Other Sources	\$0	\$0	\$0	\$0	\$0	\$0
Proposed Grants/Other Sources	\$18,000,000	\$0	\$1,000,000	\$6,000,000	\$11,000,000	\$0
Total	\$18,000,000	\$0	\$1,000,000	\$6,000,000	\$11,000,000	\$0

ALL PROJECTS BY CATEGORY

Project Name	Project Number	Plan Ref	Project Type	Total Budget	Budget by Year				
					2025	2026	2027	2028	2029
State of Good Repair									
Carrollton Double Crossover	2019-FG-01	TAM	Reliability	\$4,304,114	\$2,000,000	\$0	\$0	\$0	\$0
St Charles Downtown Loop - Phase 4	2023-FG-01	TAM	Reliability	\$12,500,000	\$2,187,500	\$10,312,500	\$0	\$0	\$0
Facilities Improvement Projects	2024-FA-05	PR21	Reliability	\$1,713,083	\$1,642,625	\$570,458	\$0	\$0	\$0
Bus Lift Replacement	2024-FA-06	TAM	Reliability	\$1,983,397	\$1,983,397	\$0	\$0	\$0	\$0
Streetcar Infotainment Monitor Replacement	2024-FL-02	TAM	Reliability	\$950,000	\$162,000	\$648,000	\$0	\$0	\$0
Hydraulic Tamper	2024-FL-03	TAM	Reliability	\$900,000	\$900,000	\$0	\$0	\$0	\$0
AC Unit Replacement Streetcars	2024-FL-06	TAM	Reliability	\$700,000	\$700,000	\$0	\$0	\$0	\$0
Streetcar Wheel Replacement	2024-FL-07	TAM	Reliability	\$1,147,364	\$574,182	\$0	\$0	\$0	\$0
Bus Engine Repower	2025-FL-01	TAM	Reliability	\$1,000,000	\$1,000,000	\$0	\$0	\$0	\$0
Asset Management Inventory	OP-2024-01	BR27	Reliability	\$1,000,000	\$860,000	\$0	\$0	\$0	\$0
Streetcar System PM	PM-2024-01	TAM	Reliability	\$1,000,000	\$0	\$0	\$0	\$0	\$0
Fleet									
Zero-Emission Bus Pilot	2022-FL-05	BR28	Modernization	\$6,705,938	\$272,187	\$6,388,386	\$0	\$0	\$0
Zero-Emission, Resilient Fleet	2023-FL-02	BR28	Modernization	\$81,923,684	\$11,992,537	\$19,987,562	\$49,692,760	\$0	\$0
Hydraulic Tamper	2024-FL-03	TAM	Reliability	\$900,000	\$900,000	\$0	\$0	\$0	\$0
Fleet Support Vehicles	2024-FL-05	TAM	Reliability	\$770,000	\$770,000	\$0	\$0	\$0	\$0

Project Name	Project Number	Plan Ref	Project Type	Total Budget	Budget by Year				
					2025	2026	2027	2028	2029
Paratransit Fleet Replacement (2026)	CIP-2023-02	TAM	Reliability	\$2,664,000	\$0	\$2,664,000	\$0	\$0	\$0
Fixed-Route Fleet Replacement (2026)	CIP-2023-07	CO2	Reliability	\$14,000,000	\$0	\$14,000,000	\$0	\$0	\$0
Facilities									
Downtown Transit Center	2015-FA-01	PR21	Expansion	\$33,033,631	\$1,815,290	\$6,988,650	\$24,224,976	\$0	\$0
Algiers Ferry Buildings Renovation	2019-MA-01	UP4	Modernization	\$9,689,536	\$6,449,826	\$2,637,523	\$0	\$0	\$0
UPT Admin Office Renovation	2022-FA-01	UP3	Modernization	\$5,000,000	\$2,618,667	\$2,381,333	\$0	\$0	\$0
Interim Downtown Transit Hub Phase 2	2022-FA-04	PR21	Expansion	\$800,000	\$126,750	\$0	\$0	\$0	\$0
Transit Shelter Program	2023-FA-01	PR15	Expansion	\$2,500,000	\$500,000	\$500,000	\$500,000	\$500,000	\$500,000
All Stops Accessible Program - St Charles	2024-FA-03	BE7	Modernization	\$6,865,656	\$508,895	\$2,035,578	\$4,443,318	\$0	\$0
Mobility Hubs, Phase 1	2024-FA-04	PR23	Expansion	\$10,000,000	\$1,424,824	\$9,311,036	\$2,992,071	\$0	\$0
All Stops Accessible Program - Bus	2024-FA-07	BE7	Modernization	\$11,500,000	\$0	\$500,000	\$1,000,000	\$5,000,000	\$5,000,000
Mobility Hubs, Phase 2	CIP-2023-01	PR23	Expansion	\$33,000,000	\$0	\$0	\$9,000,000	\$4,500,000	\$4,500,000
Fixed Guideway									
BRT East-West Bank Corridor	2021-FG-01	CO3	Expansion	\$282,473,949	\$3,000,000	\$5,085,516	\$17,565,484	\$70,261,937	\$70,261,937
Uptown-Downtown Streetcar Connector (Howard Av)	CIP-2016-01	UP2	Expansion	\$9,500,000	\$0	\$500,000	\$4,000,000	\$5,000,000	\$0
BRT Extension, River District	CIP-2023-03	CO3	Expansion	\$10,000,000	\$0	\$0	\$0	\$5,000,000	\$5,000,000
Riverfront Streetcar Extension	CIP-2023-04	UP2	Expansion	\$17,000,000	\$0	\$0	\$1,000,000	\$5,000,000	\$11,000,000

Project Name	Project Number	Plan Ref	Project Type	Total Budget	Budget by Year				
					2025	2026	2027	2028	2029
Streetcar Corridor Modernization	CIP-2023-05	UP2	Modernization	\$5,750,000	\$250,000	\$500,000	\$0	\$5,000,000	\$0
Select Bus Corridor Improvements	CIP-2023-06	CO1	Modernization	\$10,750,000	\$200,000	\$550,000	\$0	\$5,000,000	\$5,000,000
Technology									
Fare Technology Modernization	2022-IT-02	PR4	Modernization	\$8,636,588	\$1,386,588	\$7,250,000	\$0	\$0	\$0
Paratransit Software Modernization	2023-IT-03	BR1	Modernization	\$500,000	\$500,000	\$0	\$0	\$0	\$0
Radio Infrastructure Modernization	2023-IT-07	UP9	Modernization	\$4,223,598	\$734,650	\$759,851	\$788,746	\$0	\$0
Timekeeping Software Modernization	2024-IT-03	BR1	Modernization	\$600,000	\$600,000	\$0	\$0	\$0	\$0
Marine									
Algiers Ferry Barges Replacement	2022-MA-01	UP4	Modernization	\$13,670,149	\$10,375,443	\$2,593,861	\$0	\$0	\$0
Marine Vessel Repair Contingency	2024-MA-01		Reliability	\$1,500,000	\$500,000	\$500,000	\$500,000	\$500,000	\$500,000
				Total Budget	Budget by Year				
					2025	2026	2027	2028	2029
Summary									
			Total Capital Investment Program (CIP)	\$627,268,271	\$59,471,878	\$99,963,404	\$145,501,090	\$154,833,215	\$152,384,745
			Secured Awards	\$198,044,404	\$41,962,945	\$54,916,555	\$68,628,428	\$0	\$0
			Proposed Funding	\$159,101,877	\$0	\$23,235,753	\$43,755,375	\$92,110,750	\$89,110,750
			Proposed Bond Proceeds	\$78,074,763	\$0	\$0	\$12,805,914	\$49,571,278	\$51,122,808
			Local (RTA) Funds	\$79,723,524	\$17,508,933	\$21,811,096	\$20,311,373	\$13,151,187	\$12,151,187

Notes:

1. All amount in 2024 dollars
2. Total Budget by funding source will not total due to budgets for projects including pre-2025 cost

THIS PAGE IS INTENTIONALLY LEFT BLANK

DRAFT



Board Report and Staff Summary

File #: 25-025

Finance Committee

2024 Annual Fare Report

DESCRIPTION: DESCRIPTION: Per the agency’s Fare Policy (Gen11), RTA staff will present an Annual Fare Report to inform the Board of Commissioners and the public of RTA’s performance relative to its Fare Policy Objectives.	AGENDA NO: Click or tap here to enter text.
ACTION REQUEST: <input type="checkbox"/> Approval <input type="checkbox"/> Review Comment <input checked="" type="checkbox"/> Information Only <input type="checkbox"/> Other	

RECOMMENDATION:

This is an informational report for the benefit of the RTA Board of Commissioners. The attached report summarizes gross fare revenue and total sales from the calendar year 2024 with comparisons to 2023 to illustrate year-over-year changes in rider behavior.

ISSUE/BACKGROUND:

In 2024, riders took over 14 million unlinked passenger trips (UPT) while spending over \$11 million on fare products to access RTA services. The attached report summarizes how much revenue RTA riders spent on fare products, what sales channels they used, and how those outcomes compare to 2023. It also includes a breakdown of what fare products were purchased in 2024 by rider discount type, bypass type, and by length of time-based pass.

A summary of special fare programs and overall fare access is also included.

DISCUSSION:

Highlights from the attached report include the finding that, although total gross passenger fares remained relatively steady from 2023 to 2024, riders bought an increasing share of their fare products before boarding a vehicle (the ‘pre-paid’ rate was approximately 49% in 2024 vs. 41% in 2023). This advances a goal of NORTA’s Strategic Mobility Plan to shift more purchase activity away from vehicle doors (and to pre-paid sales channels) in pursuit of faster boarding and more efficient service.

Also of note, RTA collected a similar gross revenue per unlinked passenger trip in 2023 and 2024- approximately \$0.79 per rider.

FINANCIAL IMPACT:

Click or tap here to enter text.

NEXT STEPS:

RTA Staff will prepare a separate report estimating the costs of fare collection.

ATTACHMENTS:

1. CY24 Annual Fare Report

Prepared By: Jack Duffy
Title: Manager, Fare Policy & Systems

Reviewed By: Gizelle Banks
Title: Chief Financial Officer



3/11/2025

Lona Edwards Hankins
Chief Executive Officer

Date

Annual Fare Report & Fare Structure Review

Report Year 2024

Introduction

The New Orleans Regional Transit Authority is committed to providing its riders and other public stakeholders with accurate, timely information related to all Fare Elements.

The Annual Fare Report outlines sales and gross fare revenue by sales channel; mode; and fare media. It also includes a summary of pass sales programs and of where fares are accessible. An outline of the cost of fare collection will follow in a separate report.

As established in the agency’s fare policy, the objectives of RTA’s fare programs are as follows:

Improve Service	Orient Fare-Related Decisions towards enhancing service reliability and increasing overall speed of service.
Maximize Ridership to Drive Revenue for Service Expansion	Set fare structure and fare pricing to maximize ridership and ensure consistent sales growth for investment into service enhancements.
Advance Diversity, Equity, and Inclusion	Approach Fare Elements and Fare-Related Decisions with a focus on diversity, equity, and inclusion and a commitment to equitable access and outcomes for riders.
Enhance Connectivity	Utilize Fare Elements to enhance regional connectivity and integration across all modes of transportation.
Increase Efficiency and Simplicity	Increase speed and efficiency of rider boarding and simplicity of Fare Elements for customers.
Prioritize Local, Regular Riders	Prioritize regular riders through all Fare Elements, while reducing barriers to entry for new riders.
Minimize Operator Involvement in Fare Collection	Minimize the role of operators in fare collection and fare disputes to allow them to focus on providing safe, reliable, and welcoming service.
Optimize Return on Investment	Optimize the value of capital and operating expenditures on Fare Elements.

Background

NORTA sells fares for its fixed-route service through sales channels in four broad categories:

1. **At-Vehicle** purchases made at the farebox of a bus or streetcar in revenue service or with deckhands when boarding a ferry;
2. at Ticket Vending Machines (**TVMs**) located in front of the A. Phillip Randolph Administrative Building at 2817 Canal Street and the Canal Street Ferry Terminal;
3. on **Mobile** platforms, i.e. passes available through the Le Pass app and other Token Transit-supported apps;
4. via **RTA Administrative** staff, whether at the Customer Service desk inside the A. Phillip Randolph Building, through the agency's website (and later mailed), or institutional 'client' sales.

NORTA passes sold at third-party brick-and-mortar retail locations (e.g. Walgreen's) are recorded as Client sales in this report.

Fare collection for fixed-route service involves on-vehicle farebox systems that accept cash, coins, and paper passes; those systems issue mag-stripe passes and change cards.

TVMs accept cash and credit cards and print paper, magnetic-stripe tickets that are validated at on-vehicle fareboxes, or, in the case of TVMs at the Canal Street Ferry Terminal, validated upon issuance.

Mobile ticketing is carried out in partnership with Token Transit as a back-end payment collection system. Most mobile passes are sold through the agency's branded, Moovit-developed white-label app, Le Pass. Token Transit also facilitates fare sales and validation through the Transit app, Google wallet, the Moovit, and the Token Transit app.

Magnetic-stripe pass products are also sold via direct sale from the agency. They are distributed at the customer service desk in the lobby of RTA headquarters when purchased in person, via USPS after purchase online at norta.com/store, or delivered locally by the agency for large purchases. Retail partners sell fare products at 15 locations across the city near some of the highest ridership locations.

Fare Table

NORTA sold the following fare products at the corresponding prices in RY2024:

	Adult	Priority Rider	Youth
Single-Ride Fare	\$ 1.25	\$ 0.40	\$ 0.50
Single-Ride Ferry Fare	\$ 2.00	\$ 1.00	\$ 1.00
SR Ferry Vehicle Driver	\$ 2.00	\$ 1.00	\$ 1.00
SR Ferry Vehicle Passenger	\$ 1.00	\$ 1.00	\$ 1.00
SR Ferry Driver + Trailer	\$ 5.00	\$ 4.00	\$ 4.00
SR Ferry Trailer Only	\$ 3.00	\$ 3.00	\$ 3.00
Regional Ride	\$ 6.00		
1-Day Jazzy Pass	\$ 3.00	\$ 0.80	\$ 1.00
3-Day Jazzy Pass	\$ 8.00		
7-Day Jazzy Pass	\$ 15.00		
31-Day Jazzy Pass	\$ 45.00	\$ 14.00	\$ 18.00

Annual Fare Revenue Report

Gross Fare Revenue by Sales Channel

The overall list price value of fare products sold by NORTA increased by 2.6% from 2023 to 2024. Ridership correspondingly changed by 12% on bus, -7.8% on streetcar, and -13.5% on ferry, year over year.

The following table displays the gross sales for RY2023 and RY2024, arranged by point of sale.

Point of Sale	2023	2024	RY24 YOY Change
At Vehicle	\$ 6,596,894.58	\$ 5,920,461.43	-10.3 %
TVM	\$ 40,889.95	\$ 70,804.85	73.2 %
Mobile	\$ 3,727,997.40	\$ 4,525,239.95	21.4 %
Admin	\$ 850,929.88	\$ 988,832.62	16.2 %
Total	\$ 11,216,711.81	\$ 11,505,338.85	2.6 %

The following table displays the total ridership recorded for RY2023 and RY2024, by mode.

Mode	2023	2024	RY24 YOY Change
Bus	8,706,476	9,749,386	12.0 %
Streetcar	3,859,266	3,557,751	-7.8 %
Ferry	967,648	836,788	-13.5 %
Paratransit	229,227	221,091	-3.5 %
Total	13,762,617	14,365,016	4.4 %

The same data, breaking out each mode for ‘At Vehicle’ and each administrative point of sale for ‘Admin’ is included below for further context. The year-over-year growth in pre-paid sales through mobile and direct sales from RTA admin staff (In-House / Client Sales) are significant. Decreases of collections at the ferry are due in part to service disruptions on the Chalmette ferry.

Source	2023	2024	RY24 YOY Change
Bus Farebox	\$ 3,228,400.69	\$ 3,234,552.94	0.2 %
Streetcar Farebox	\$ 2,201,346.72	\$ 1,786,164.03	-18.9 %
Ferry Ops	\$ 836,210.78	\$ 589,864.07	-29.5 %
Paratransit Ops	\$ 330,936.39	\$ 309,880.39	-6.4 %
TVM	\$ 40,889.95	\$ 70,804.85	73.2 %
Mobile	\$ 3,727,997.40	\$ 4,525,239.95	21.4 %
In-house / Client Sales	\$ 408,091.53	\$ 582,032.43	42.6 %
Website	\$ 376,613.20	\$ 348,600.30	-7.4 %
Customer Service	\$ 66,225.15	\$ 58,199.89	-12.1 %
Total	\$ 11,216,711.81	\$ 11,505,338.85	2.6 %

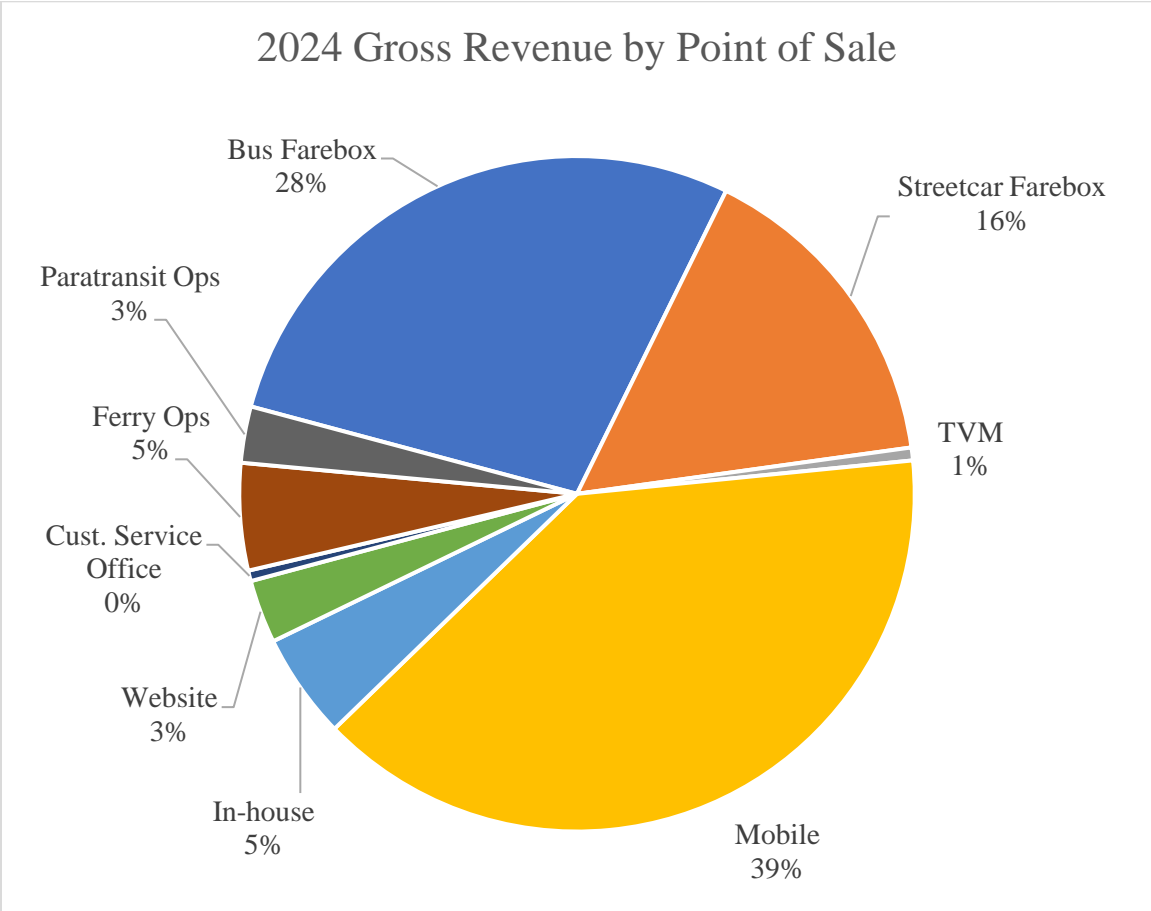

Revenue by Media

The table below displays the gross fare revenue collected by the fare media purchased. The two columns on the right display the share of gross revenue by media for the current reporting year (2024) and the previous year (2023) for comparison.

Medium	2024 Revenue	2024 %	2023 Revenue	2023 %
Paper Ticket	\$ 6,650,843.51	59.4%	\$ 7,134,653.02	65.5%
Mobile Pass	\$ 4,525,239.95	40.4%	\$ 3,727,997.40	34.2%
Token	\$ 19,375.00	0.2%	\$ 23,125.00	0.2%

In parallel with the shift from farebox purchases to mobile purchases shown in the section on points of sale, there has been a notable shift from paper tickets towards mobile tickets year on year.

Revenue by Pre-Paid Status

Source	2024 Gross Rev.	2024 Share	2023 Share
On Vehicle	\$ 5,610,581.04	50.1%	57.6%
Pre-Paid	\$ 5,584,877.42	49.9%	42.4%

Consistent with previous fare revenue breakdowns showing a shift from at-vehicle purchases towards mobile and direct agency sales, the overall share of fare revenue collected from pre-paid fare product purchases has grown year over year.

In 2024, almost 50% of passenger revenue was collected away from the doors of vehicles, marking significant progress towards an agency goal in the Strategic Mobility Plan for more pre-paid purchases. In fact, for the last four months of 2024, more revenue was collected in pre-paid sales.

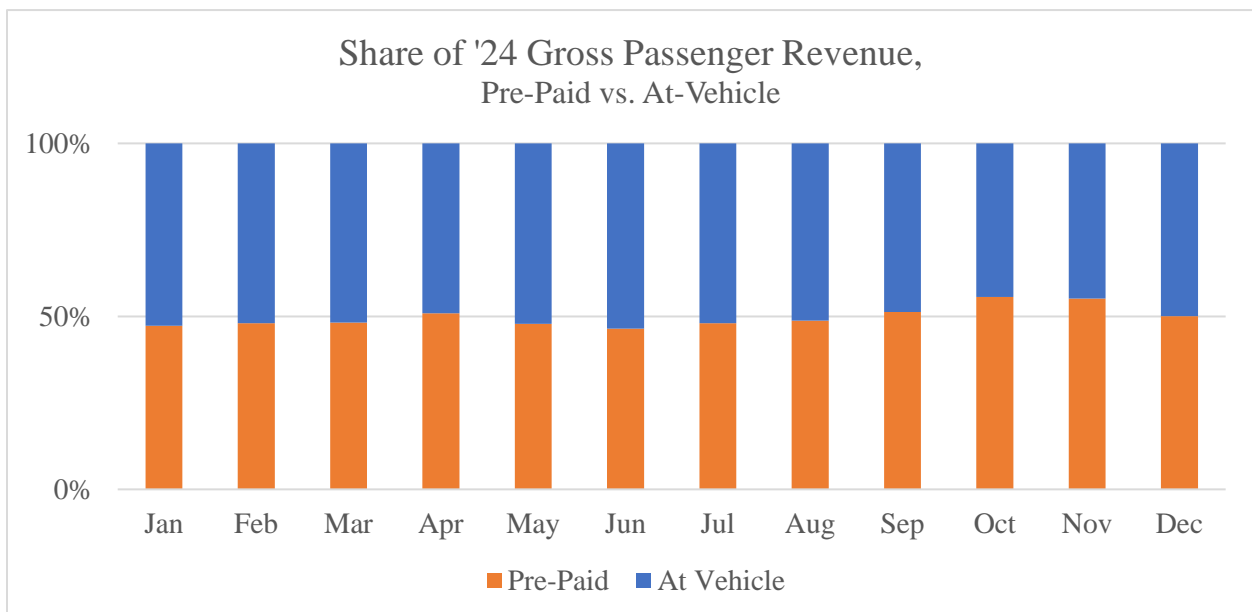

Revenue by Mode

The following tables show the share of passenger revenue that can be assigned to each of the transit modes operated by RTA for 2024 and 2023 for comparison. Paratransit fares are unique to paratransit.

The gross value of fare products purchased at the point of embarkation are assigned to the mode where they were purchased (e.g. a 1-day Jazzy Pass purchased at a bus farebox is assigned to bus revenue).

For pre-purchased products, fares specific to bus and streetcar (e.g. a \$1.25 adult single ride fare) are assigned to bus and streetcar as a function of ridership. The gross value of jazzy pass products (eligible on all three fixed route modes) are assigned across all three modes according to ridership. Ferry specific products are assigned entirely to ferry revenue.

Mode	2024 Ridership	'24 Est. Gross Revenue	Gross \$ / Rider
Bus	9,749,386	\$ 6,968,530.11	\$ 0.71
Streetcar	3,557,751	\$ 3,148,768.92	\$ 0.89
Ferry	836,788	\$ 1,078,159.43	\$ 1.29
Paratransit	221,091	\$ 309,880.39	\$ 1.40
Total	14,365,016	\$ 11,505,338.85	\$ 0.80

Mode	2023 Ridership	'23 Est. Gross Revenue	Gross \$ / Rider
Bus	8,706,476	\$ 6,119,625.27	\$ 0.70
Streetcar	3,859,266	\$ 3,482,922.03	\$ 0.90
Ferry	967,648	\$ 1,283,228.12	\$ 1.33
Paratransit	229,227	\$ 330,936.39	\$ 1.44
Total	13,762,617	\$ 11,216,711.81	\$ 0.82

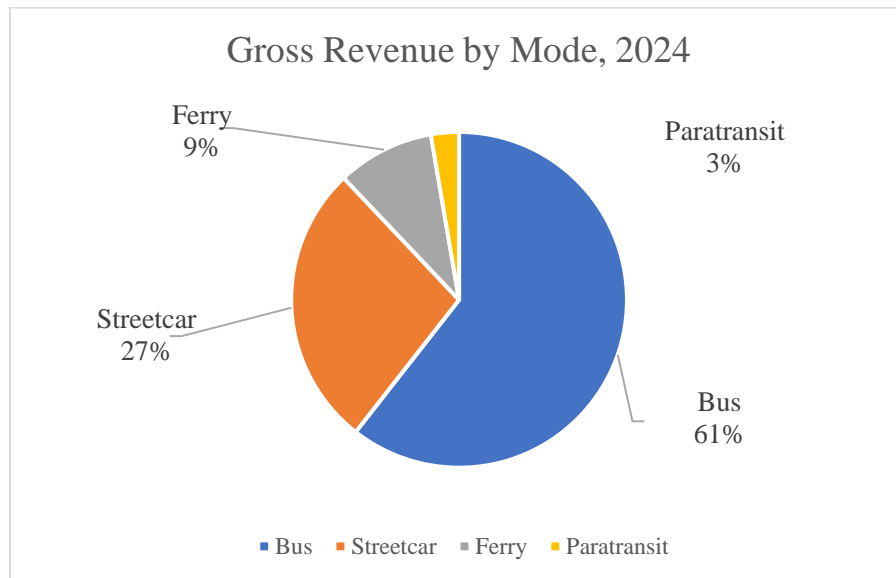

Fare Product Sales by Point of Sale, Product Type, Rider

The table below shows a comparison of total transactions across all points of sale in 2024, by rider type and fare type where applicable. Breakdowns indicate which types of fare products are being purchased where and by whom. Unclassified revenue collected at fixed route vehicles is not assigned to fare products for the purposes of this analysis.

Overall Sales by Product Type				
Product Type	Adult	Priority Rider	Youth	Grand Total
Ferry Single Ride	98,915	4,522	6,858	110,295
Bus-SR Single Ride	3,485,561	248,804	178,544	3,912,909
Jazzy Pass	902,647	634,382	283,988	1,821,017
Opportunity Pass	31,992		14,575	46,567
Regional Ride	20,888	218	607	21,713
U-Pass	50			50
Grand Total	4,540,053	887,926	484,572	5,912,551

Share of Total Sales				
Product Type	Adult	Priority Rider	Youth	Grand Total
Ferry Single Ride	2.18%	0.51%	1.42%	1.87%
Bus-SR Single Ride	76.77%	28.02%	36.85%	66.18%
Jazzy Pass	19.88%	71.45%	58.61%	30.80%
Opportunity Pass	0.70%	0.00%	3.01%	0.79%
Regional Ride	0.46%	0.02%	0.13%	0.37%
U-Pass	0.00%	0.00%	0.00%	0.00%
Grand Total	100.00%	100.00%	100.00%	100.00%

The overwhelming majority of fare products sold are bus-streetcar single-ride fares. Adult (full price) riders engage with the system very differently than discounted riders (priority riders and youth).

Because a full-price 1-day Jazzy Pass costs more than twice as much as a single ride for adult riders, riders only planning a round-trip save money by buying two separate fare products in separate transactions, rather than one Jazzy Pass to cover travel for the day ($\$1.25 \times 2 = \2.50 , rather than one \$3 Jazzy Pass). The high share of Jazzy Pass sales for Priority Riders and Youth suggests the pricing incentive is significant.

When the agency next changes fares, aligning round-trip adult single ride fares with the price of a 1-day Jazzy Pass has the potential to reduce the number of individual purchases being made with a pricing incentive.

Tables below break out the share of products sold within different product categories.

Day Pass Products	Total Passes (#)	Transit Access (Days)
Adult	923,535	1,836,067
Adult 1-Day Jazzy Pass	749,131	749,131
Adult 31-Day Jazzy Pass	17,292	536,052
Adult 3-Day Jazzy Pass	105,893	317,679
Adult 7-Day Jazzy Pass	30,331	212,317
Adult Regional Ride	20,888	20,888
Priority Rider	634,600	869,049
Priority Rider 1-Day Jazzy Pass	624,478	624,478
Priority Rider 31-Day Jazzy Pass	7,722	239,382
Priority Rider 3-Day Jazzy Pass	1,657	4,971
Priority Rider 7-Day Jazzy Pass	525	3,675
Priority Rider Regional 1-Day	218	218
Youth	284,595	441,721
Youth 1-Day Jazzy Pass	274,957	274,957
Youth 31-Day Jazzy Pass	4,858	150,598
Youth 3-Day Jazzy Pass	3,413	10,239
Youth 7-Day Jazzy Pass	760	5,320
Youth Regional 1-Day	607	607
Grand Total	1,842,730	3,150,512

The following graph indicates the relative transit access purchased via different day-based fare products. While this will likely overvalue the 1-day and 31-day Jazzy Passes—there are no 3-day or 7-day passes discounted for Priority Rider or Youth—it indicates that a majority of riders purchase RTA services in small increments. Taken with the relative rates of single ride vs. jazzy pass use above, most riders purchase their transit in units of single days, rather than months, despite the relative discount presented by 31-day pass pricing (e.g. one day of transit for an Adult is \$3 with a 1-day pass but only \$1.45 with a 31-day pass).

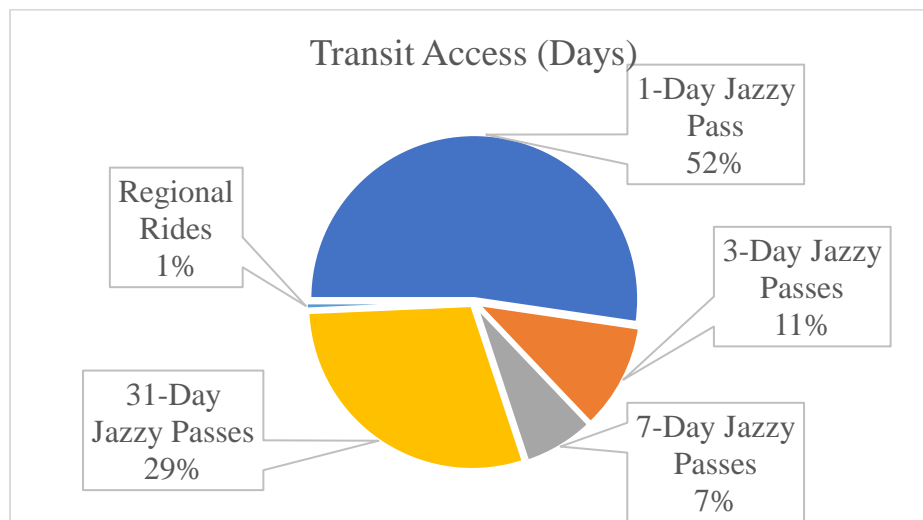

Special Pass Products	Total Passes (#)
Adult	52,930
Adult Regional Ride	20,888
Delgado U-Pass	50
Opportunity Pass (Adult)	31,992
Priority Rider	218
Priority Rider Regional 1-Day	218
Youth	15,182
Opportunity Pass (Youth)	14,575
Youth Regional 1-Day	607
Grand Total	68,330

Ferry Single Ride Products	Total Passes (#)
Adult	98,915
Adult Ferry Trailer Only	495
Adult Ferry Vehicle + Trailer	134
Adult Ferry Vehicle Driver	22,036
Adult Ferry Vehicle Passenger	9,253
Adult Ferry Walk-on	66,997
Priority Rider	4,522
Priority Rider Ferry Trailer Only	18
Priority Rider Ferry Vehicle + Trailer	25
Priority Rider Ferry Vehicle Driver	1,431
Priority Rider Ferry Vehicle Passenger	451
Priority Rider Ferry Walk-on	2,597
Youth	6,858
Youth Ferry Trailer Only	18
Youth Ferry Vehicle + Trailer	3
Youth Ferry Vehicle Driver	772
Youth Ferry Vehicle Passenger	474
Youth Ferry Walk-on	5,591
Grand Total	110,294

Marketing / Access

Summary of Retail Network & Fare Access Points

An up-to-date list of all current retail partners and locations can be found on NORTA's website at <https://www.norta.com/ride-with-us/how-to-pay/retail-partners>. As of December 31, 2024, NORTA passes were available for purchase at 16 locations, including 11 Walgreens locations, Unique Grocery, and the Velveteen Lounge and Restaurant.

1. Walgreen's, 1826 N. Broad St., New Orleans, LA 70119
2. Walgreen's, 801 Canal St., New Orleans, LA 70112
3. Walgreen's, 900 Canal St., New Orleans, LA 70112.
4. Walgreen's, 4001 Canal St., New Orleans, LA 70119
5. Walgreen's, 718 S. Carrollton Ave., New Orleans, LA 70118.
6. Walgreen's, 2418 S. Carrollton Ave., New Orleans, LA 70118
7. Walgreen's, 619 Decatur St., New Orleans, LA 70130
8. Walgreen's, 1100 Elysian Fields Ave., New Orleans, LA 70117
9. Walgreen's, 3216 Gentilly Blvd., New Orleans, LA 70122
10. Walgreen's, 11297 Lake Forest Blvd., New Orleans, LA 70128
11. Walgreen's, 5518 Magazine St., New Orleans, LA 70115
12. Walgreen's, 7401 Read Blvd., New Orleans, LA 70127
13. Walgreen's, 134 Royal St., New Orleans, LA 70130
14. Walgreen's, 1801 Saint Charles Ave., New Orleans, LA 70130
15. Unique Grocery, 129 Royal Street, New Orleans, LA 70130
16. Velveteen Lounge and Restaurant, 2565 Bayou Road, New Orleans, LA 70119

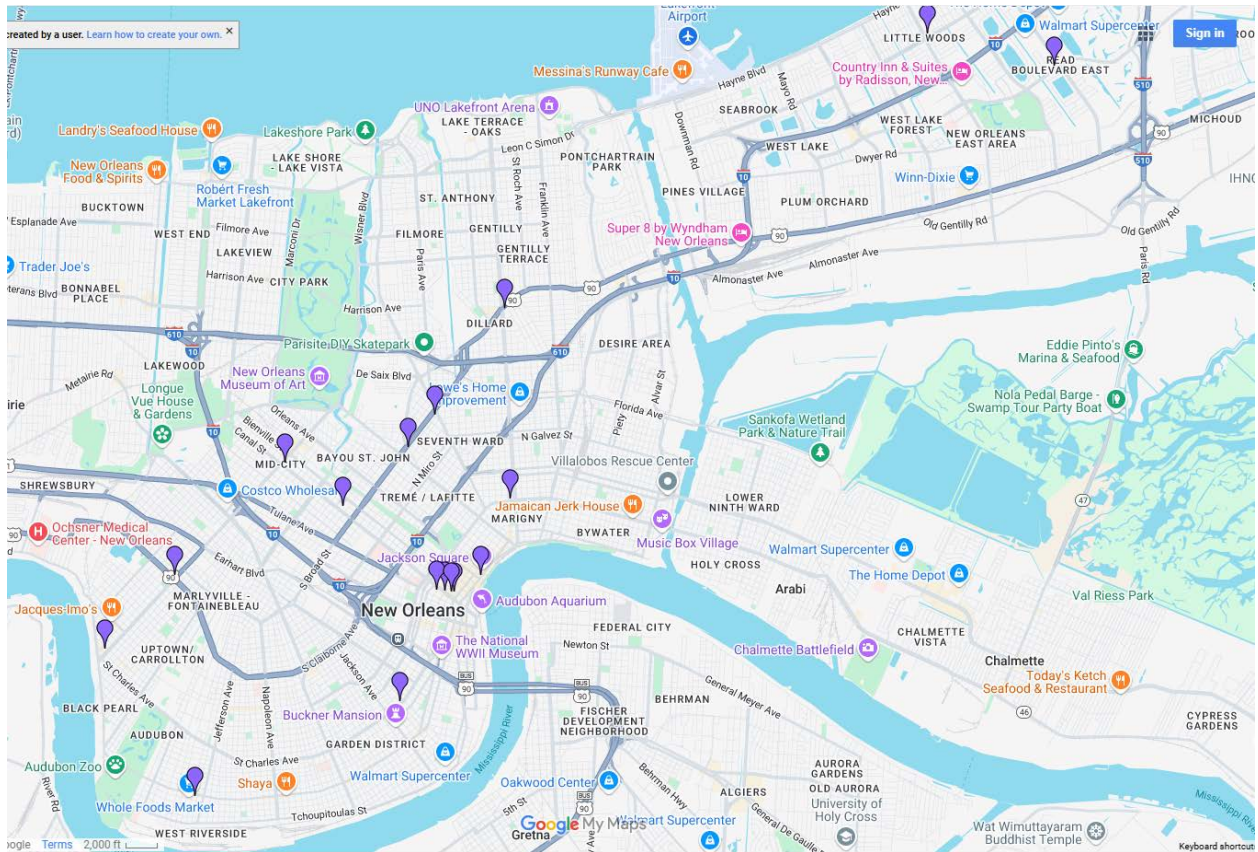

Figure 1 Locations of NORTA retail partners

Besides these retail partners, passes can be pre-purchased through NORTA’s website, in communication with NORTA’s marketing and pass sales office, on mobile devices, at the customer service desk in NORTA’s office at 2817 Canal Street during business hours, or at TVMs currently in operation in front of 2817 Canal Street and at the Canal Street Ferry Terminal.

Customer Service and Service Efficiency

Special Fare Programs

At the close of 2024, RTA had several pass sales programs in various stages of development:

In September 2024, the Opportunity Pass program launched in partnership with Ride New Orleans, New Orleans Children and Youth Planning Board, New Orleans Public Library and the City of New Orleans. The pilot program makes free one-day jazzy passes available to eligible riders—Opportunity Youth (ages 16-24) who reside in Orleans Parish and have access to the agency’s Le Pass app with a working phone number.

Through year-end 2024, there were 3,299 unique users signed up for the program. Activations of one-day passes below a monthly cap are included in tables on previous pages—in 2024 some 46,567 of these passes were activated by riders participating in the pilot.

Fare Free Days 2024

In 2024, NORTA observed seven fare-free days, as defined by the agency's Fare Policy.

1. February 4, 2024: Rosa Parks Day / Transit Equity Day
2. March 23, 2024: Election Day (Primary)
3. September 5, 2024: Claudette Colvin Day

4. October 19, 2024: Early Voting Saturday
5. October 26, 2024: Early Voting Saturday
6. November 5, 2024: Election Day (Presidential/Congressional)
7. December 7, 2024: Election Day (State Constitutional Amendments)

Estimated Fare Revenue Foregone

NORTA revenue service was impacted by Hurricane Francine for three days, from 9/11/24 to 9/13/24, in addition to the seven days listed above where fares were not sold at vehicles, on the mobile app, or at TVMs. Because 2024 was a leap year, this leaves 356 days with normal revenue service and fare collection.

A. Mode	B. Est. Annual Gross Revenue	C. Days w/ Fare Collection	D. Passenger Rev. / Fare Day	E. Fare-Free Days	F. Foregone Passenger Revenue (Total)
Bus	\$ 6,968,530.11	356	\$ 19,574.52	7	\$ 137,021.66
Streetcar	\$ 3,148,768.92	356	\$ 8,844.86	7	\$ 61,914.00
Ferry	\$ 1,078,159.43	356	\$ 3,028.54	7	\$ 21,199.76
Paratransit	\$ 309,880.39	356	\$ 870.45	7	\$ 6,093.15
Total	\$ 11,505,338.85		\$ 32,318.37		\$ 226,228.57

The table above estimates the passenger revenue foregone by the agency for each fare-free day (Total, Column D) and for all fare-free days in RY2024 (Total, Column F).



Fare Policy

(GEN11)

POLICY STATEMENT

The New Orleans Regional Transit Authority (RTA) is committed to providing high-quality public transportation services for the benefit of the individuals and communities that it serves. This mission is funded by fare revenues from riders across its service area. RTA manages all Fare Elements, including fare structure and pricing, fare marketing and access, fare technology, fare collection, and fare enforcement.

This Fare Policy references RTA's Title VI and Environmental Justice Policy Manual (last revised October 15, 2020).

PURPOSE

This Fare Policy establishes transparent guidance for all Fare Elements and Fare-Related Decisions at RTA. The policy is technology- and solution-agnostic. It establishes RTA's goals, values, and commitments as they relate to fares.

This policy will be reviewed bi-annually and will be automatically reviewed and updated in the event of the following: (1) a change in the fare structure, (2) a Major Fare Technology Change, (3) any changes in State or Local Legislation related to Fare Elements, or (4) changes to any other RTA Policies that impact Fare Elements.

APPLICATION

This policy applies to all RTA employees involved in Fare Elements or Fare-Related Decisions.

ADOPTED BY:

The RTA Board of Commissioners on 9/27/2022, Resolution 22-071.

APPROVED BY:

A handwritten signature in blue ink, appearing to read "Alex Z. Wiggins".

Alex Z. Wiggins
Chief Executive Officer

Effective Date: 9/27/2022
Date of Last Review: 9/27/2022

1.0 Fare Policy Objectives

To guide Fare-Related Decisions, RTA has developed the following Fare Policy Objectives. These objectives reflect the complexity of implementing and managing Fare Elements that (1) meet the needs of the RTA and its users, (2) address the social, environmental, and economic goals for public transportation, and (3) fulfil federal civil rights obligations.

All RTA Fare-Related Decisions are guided by the Fare Policy Objectives. Some possible strategies may achieve one objective at the expense of another. These objectives should be carefully weighed in relation to each other whenever changes to Fare Elements are proposed. RTA strives to meet all these objectives, while recognizing that competing objectives must be balanced.

Improve Service	Orient Fare-Related Decisions towards enhancing service reliability and increasing overall speed of service.
Maximize Ridership to Drive Revenue for Service Expansion	Set fare structure and fare pricing to maximize ridership and ensure consistent sales growth for investment into service enhancements.
Advance Diversity, Equity, and Inclusion	Approach Fare Elements and Fare-Related Decisions with a focus on diversity, equity, and inclusion and a commitment to equitable access and outcomes for riders.
Enhance Connectivity	Utilize Fare Elements to enhance regional connectivity and integration across all modes of transportation.
Increase Efficiency and Simplicity	Increase speed and efficiency of rider boarding and simplicity of Fare Elements for customers.
Prioritize Local, Regular Riders	Prioritize regular riders through all Fare Elements, while reducing barriers to entry for new riders.
Minimize Operator Involvement in Fare Collection	Minimize the role of operators in fare collection and fare disputes to allow them to focus on providing safe, reliable, and welcoming service.
Optimize Return on Investment	Optimize the value of capital and operating expenditures on Fare Elements.

2.0 Fare Structure Overview

Section 2.4 summarizes pricing for all RTA Fares. A full definition of each RTA fare product can be found below.

2.1 Single-Ride Fares (Bus and Streetcar)

Adult Single Fare: A two-hour, Time-Based Ticket. Passengers will receive a physical ticket with purchase of a Single Fare. Passengers may transfer to or ride any other RTA bus or streetcar within two hours of initial purchase upon presentation of their ticket.

Priority Rider Single Fare: A two-hour, Time-Based Ticket. Passengers will receive a physical ticket with purchase of a Single Fare. Passengers may transfer to or ride any other RTA bus or streetcar within two hours of initial purchase upon presentation of their ticket. The Priority Rider Single Fare is available to passengers who meet the eligibility of 'Priority Riders,' outlined in Section 6.1.

Youth Single Fare: A two-hour, Time-Based Ticket. Passengers will receive a physical ticket with purchase of a Single Fare. Passengers may transfer to or ride any other RTA bus or streetcar within two hours of initial purchase upon presentation of their ticket. The Youth Single Fare is available to passengers who meet the eligibility of 'Youth,' outlined in Section 6.1.

2.2 Single-Ride Fares (Ferries)

Adult Ferry Fare: One-way trip for a single rider on the ferry, including a vehicle weighing less than 10 tons.

Priority Rider Ferry Fare: One-way trip for a single rider on the ferry, including a vehicle weighing less than 10 tons. The Priority Rider Ferry Fare is available to riders who meet the eligibility of 'Priority Riders,' outlined in Section 6.1.

Youth Ferry Fare: One-way trip for a single rider on the ferry, including a vehicle weighing less than 10 tons. The Youth Ferry Fare is available to riders who meet the eligibility of 'Youth,' outlined in Section 6.1.

Trailer Ferry Fare: One-way trip for a single trailer pulled by a vehicle with ticketed driver, with a combined length no greater than 48 feet.

Vehicle Passenger Ferry Fare: One-way trip for a passenger within a vehicle.



2.3 Pass Products

1-Day Jazzy Pass: Provides rider with use of the RTA bus, streetcar, or ferry for 24 hours after first activation.

1-Day Jazzy Pass (Priority Rider): Provides rider with use of the RTA bus, streetcar, or ferry for 24 hours after first activation, available to passengers who meet the eligibility of 'Priority Riders,' outlined in Section 6.1.

1-Day Jazzy Pass (Youth): Provides rider with use of the RTA bus, streetcar, or ferry for 24 hours after first activation, available to passengers who meet the eligibility of 'Youth', outlined in Section 6.1.

1-Day Regional Ride: Provides riders with unlimited rides on both RTA bus, streetcar, and ferries as well as JP Transit buses for 24 hours after first activation.

3-Day Jazzy Pass: Provides rider with use of the RTA bus, streetcar, or ferry for 3 consecutive days after first activation.

7-Day Jazzy Pass: Provides rider with use of the RTA bus, streetcar, or ferry for 7 consecutive days after first activation.

31-Day Jazzy Pass: Provides rider with use of the RTA bus, streetcar, or ferry for 31 consecutive days after first activation.

31-Day Jazzy Pass (Priority Rider): Provides rider with use of the RTA bus, streetcar, or ferry for 31 consecutive days after first activation, available to passengers who meet the eligibility of 'Priority Riders,' outlined in Section 6.1.

31-Day Jazzy Pass (Youth): Provides rider with use of the RTA bus, streetcar, or ferry for 31 consecutive days after first activation, available to passengers who meet the eligibility of 'Youth', outlined in Section 6.1.

2.4 Fare Table

Current RTA fares are listed in the table below.

Single-Ride Fares (Bus and Streetcar)	
Adult Single Fare	1.25
Priority Rider Single Fare	0.40
Youth Single Fare	0.50
Single-Ride Fares (Ferry)	
Adult Ferry Fare	2.00
Priority Rider Ferry Fare	1.00
Youth Ferry Fare	1.00
Trailer Ferry Fare	3.00
Vehicle Passenger Ferry Fare	1.00
1-Day Pass	
1-Day Jazzy Pass (Adult)	3.00
1-Day Jazzy Pass (Priority Rider)	0.80
1-Day Jazzy Pass (Youth)	1.00
1-Day Regional Ride	6.00
3-Day Pass	
3-Day Jazzy Pass	8.00
7-Day Pass	
7-Day Jazzy Pass	15.00
31-Day Pass	
31-Day Jazzy Pass (Adult)	45.00
31-Day Jazzy Pass (Priority Rider)	14.00
31-Day Jazzy Pass (Youth)	18.00

3.0 Change and Refunds

3.1 Change Policy

RTA does not provide change on the bus or streetcars. Passengers paying cash shall be provided with a “change card” usable on all RTA buses and streetcars in lieu of cash change. RTA does not provide change or change card on the ferries.

3.2 Refund Policy

Other than the cases established below, sales of fares and pass products (including Promotional Fares) are non-refundable. Riders shall be eligible for a replacement fare under the following circumstances:

- In the case of a major defect associated with any fare media.
- In the event that fare products are not delivered upon purchase for any reason.
- In the case of exceptional, unexpected service suspensions.

All fare refunds shall be processed through RTA’s customer service center (Rideline). All refunds shall be made at the discretion of RTA for passes purchased within 90 days.

4.0 Fare Reporting Requirements

4.1 Annual Fare Report

RTA is committed to providing its riders and other public stakeholders with accurate, timely information related to all Fare Elements. This information will serve to inform the Board of Commissioners and the public of RTA's performance relative to its Fare Policy Objectives. RTA will complete an Annual Fare Report with the following information:

Fare Revenue

- Total Fare Revenue (by Mode)
- Fare Revenue by Fare Media
- Fare Revenue by Sales Channel
- Fare Revenue / Rider (by Mode)

Fare Collection Costs

- Total Fare Collection Costs
- Fare Collection Costs by Mode
- Fare Collection Costs by Fare Media
- Fare Collection Costs by Sales Channel

Marketing / Access

- Summary of Retail Network and Fare Access Points
- Overview of Pass Sales Programs

Customer Service and Service Efficiency

- Dwell Time / Boarding Time per Boarding
- Dwell Time / Boarding Time per Fare Media
- Survey Results on fare access and reliability
- Reporting on special fare programs or fare pilots

The Annual Fare Report shall be provided to the Board of Commissioners by March of each Calendar Year. The Annual Fare Report will use the same reporting standards and methodology as the Federal Transit Administration's National Transit Database (NTD).

5.0 Fare Changes

RTA's mission is funded by fare revenues, and the provision of world-class service is dependent on the collection of fares as operating revenue. As such, it's critical that RTA consistently evaluate its fare structure to determine the extent to which existing pricing provides sufficient funding to meet the Agency's goals.

5.1 Fare Review Requirements

The RTA Finance Department will complete a Fare Structure Review every two years (the first of which was completed in January 2022), as well as at the occurrence of any of the following:

- Implementation of a Major Fare Technology Change
- Completion of a Temporary Fare Structure

The Fare Structure Review will include an analysis of all data reported in Section 4.1 "Annual Fare Report" in addition to the following:

- An analysis of the fare pricing and fare structure of peer agencies
- Focus groups with RTA staff (including operators) to determine the extent to which the current fare structure is meeting the Agency's broader objectives
- Surveys with ridership to determine the appropriateness of current fares

The Fare Structure Review will make recommendations to the Board of Commissioners as to whether changes to fare structure or fare pricing would help the RTA better achieve the goals laid out in Section 1.0 Fare Policy Objectives.

5.2 Fare Adjustment Requirements

Adjustments to fare structure or fare pricing (other than Promotional Fares as defined in Section 5.4) shall be approved by the Board of Commissioners.

All adjustments to fare structure or fare pricing (other than Promotional Fares as defined in Section 5.4) shall be approved by the New Orleans City Council as established in Section 12(b) of Article III of the Transit Agreement executed between the City of New Orleans and the RTA on June 28, 1983.

Implementing an adjustment in RTA's fare structure or fare pricing requires satisfying the Agency's Title VI Requirements, including the performance of a Fare Analysis and the development and implementation of a Public Participation Plan. All Title VI Requirements associated with implementing an adjustment in RTA's fare structure or fare pricing are established in the Title VI and Environmental Justice Policy Manual.

5.3 Temporary Fare Structure

RTA is authorized to implement a Temporary Fare Structure without satisfying its Title VI Requirements if the temporary fare reduction lasts less than six months. A Temporary Fare Structure must still be approved by the Board of Commissioners and the New Orleans City Council as defined in Section 5.2.

5.4 Promotional Fare Discounts

Promotional distribution of discounted fares is necessary for the promotion of RTA's transit system. The Chief Executive Officer of the RTA, or their designee, is therefore authorized to approve distribution of discounted or free tickets and passes for the following one-time purposes:

- To provide an individual with an incentive to take their first trip on RTA
- To retain existing riders
- To encourage existing riders to ride the transit system more often and for different trip purposes
- To encourage individuals to use new or different modes
- To shift patrons from over-utilized services and amenities to under-utilized services and amenities of the transit system
- To incentivize the use of new fare media

The justification for such promotional fares must be documented at the time of approval and included in the subsequent Annual Fare Report described in Section 4.1.

RTA retains the ability to offer Fare Free Days when no fare will be required to ride RTA services. Fare Free Days shall be announced at least one week in advance and must be approved by RTA's Executive Leadership Team. Eliminating fares for more than ten consecutive days constitutes either a Temporary Fare Structure (defined in Section 5.3) or a Suspension of Fares (established in Section 5.7).

Fare discounts to be implemented for more than one day, including free fares, will include a written justification and financial analysis when seeking the approval of the CEO or their designee. The justification and analysis will be documented and reported in the subsequent Annual Fare Report.

5.5 Election Days

Certain election days are to be observed with fare-free transit, by resolution of the RTA Board of Commissioners, to help the riding public get to their designated polling places.

5.6 Rosa Parks Day and Claudette Colvin Day



Rosa Parks Day shall be observed each year on Rosa Parks' February 4 birthday. Claudette Colvin Day shall be observed each year on Claudette Colvin's September 5 birthday. To honor their courageous assertions of equal rights for African Americans and to commemorate their historic roles in America's Civil Rights movement, no fares will be collected for transit services on Rosa Parks Day nor on Claudette Colvin Day.

5.7 Suspension of Fares

The RTA provides emergency transportation to the public when called upon to assist by the City of New Orleans and City of Kenner in accordance with the RTA's All Hazards Plan. The Chief Executive Officer has been authorized via a formal Cooperative Endeavor Agreement with the City of New Orleans and City of Kenner to suspend fare collection for those resources providing emergency transportation as emergency protective measures.

Additionally, under the RTA's All Hazards Plan, the RTA may receive formal requests outside of a mandatory City-wide evacuation for emergency transportation. The CEO is also authorized to suspend the collection of fares for these specific requests.

The RTA Incident Management Team (if activated) or the RTA's Emergency Management Department will notify the CEO when fares will be suspended, for how long, and for what specific assets.

6.0 Fare Categories

6.1 Fare Categories and Eligibility

RTA is committed to providing equitable transit access to all our riders via fares in three categories—Adult, Priority Riders, and Youth—where:

“Adult” riders are those aged 19 to 64 years of age, or who do not otherwise match one of the categories below.

“Priority Rider” is defined as any of the following:

- Any person over 65 years of age.
- Any person who is a Veteran of the United States Armed Forces
- Any person who qualifies as disabled through the following: (1) any person registered legally blind by the Commission for the Blind; (2) any person registered disabled by the Social Security Administration; (3) any person certified 100% disabled by the Veterans Administration; (4) any person qualifying as Temporarily Disabled or Disabled through RTA’s Paratransit Service Eligibility Criteria; (5) any person receiving Medicare with a Medicare Card.

“Youth” is defined as (1) any person under 19 years of age; or (2) any person who is a Kindergarten through Grade 12 student.

The discounted fares offered to Priority Riders and Youth are defined within Table 1 Current RTA Fare Pricing in Section 2.4.

6.2 Free Fare Eligibility

The individuals and members of groups listed below are eligible to ride RTA for free:

- Children five years of age and younger when accompanied by an adult
- Uniformed and badged Law Enforcement Officers as defined by Louisiana Revised Statute 40:2402
- Uniformed and badged Fire Fighter as defined by Louisiana Revised Statute 39:1991(A)

Per Transportation Pass Policy (HC19), RTA also issues transportation passes to eligible individuals. Transportation passes are valid as fare media on all RTA transit services. Full definitions of eligible parties and guidelines for transportation passes can be found in Transportation Pass Policy (HC19).

7.0 Pass Sales Programs

7.1 Retail Sales

RTA partners with select retailers to provide additional cost-effective distribution outlets for RTA passes. By expanding RTA's sales network, RTA is helping drive local retail sales through small businesses. RTA discounts the fares sold to retailers as identified in the table below. By selling RTA passes, retailers agree to sell the passes at the prices listed in Section 2.4. If a retail outlet is found to be in violation of this policy, RTA reserves the right to limit or suspend retail sales to that establishment.

Pass Type	Discount 50-499	Discount 500 or more*
1-Day	5%	10%
1-Day Youth	5%	10%
1-Day Priority	5%	10%
3-Day	5%	10%
7-Day	5%	10%
31-Day Youth	5%	10%
31-Day Priority	5%	10%
31-Day	5%	10%

*500 applies to total passes in one transaction, regardless of pass type

7.2 Non-Retail Bulk Discount

Bulk Discounts are offered to any organizations looking to purchase 50 or more multi-day passes in a single transaction. Organizations may not re-sell Bulk Discount passes. If an organization is found to be in violation of this policy, RTA reserves the right to limit or suspend future bulk discounts to that organization.

Pass Type	50 or more	500 or more	1,500 or more	2,500 or more
3-Day	5%	10%	15%	20%
7-Day	5%	10%	15%	20%
31-Day	5%	10%	15%	20%
31-Day Youth	5%	10%	15%	20%
31-Day Priority	5%	10%	15%	20%



7.3 University Pass

Colleges and universities in the Greater New Orleans Region can offer their students discounted RTA fare media through the University Pass Program. RTA offers Colleges and Universities Semester Passes at a rate of \$85 per Academic Term per student. Semesters are defined as following:

- Fall
- Spring
- Summer

University Passes are only offered to students at colleges and universities who have opted into RTA's University Pass Program.

8.0 Fare Media and Accessibility Commitments

8.1 Fare Media Diversity

RTA is committed to offering fares across diverse media, giving riders the opportunity to purchase fares in the format that best suits their needs. Even as RTA enhances its fare technology, it is committed to meeting the needs of its riders who use physical passes and pay for fares with cash. Further, RTA is committed to providing equal fares regardless of point of sale.

RTA's Title VI Policy identifies the responsibility of the agency to avoid service and policy changes that will result in discriminatory or disparate impacts on the communities it serves. In this spirit, RTA recognizes that its fare offerings must meet the diverse needs of its ridership. As RTA implements new fare technology, it will ensure that equitable access and mobility are offered to all riders. No group of riders should bear an unfair or disproportionate burden of RTA Fare-Related Decisions.

8.2 Equal Access Commitments

RTA is committed to ensuring equitable geographic access to fare products throughout its service area. Distribution of RTA fare media points of purchase should support the Agency's Title VI objective to provide a level and quality of service sufficient to provide equal access and mobility for any person, regardless of race, color, national origin, English-language proficiency, or access to non-cash payments.

RTA will affirmatively improve access for minority and low-income riders to purchase fares in the media that best suit their needs. Riders across RTA's service area will enjoy similar access to fares in the media of their choosing. RTA commits to appropriately informing riders of upcoming changes in fares, fare media, and available fare products. RTA will effectively communicate changes to the communities in its service area.

RTA is committed to training riders on relevant fare technology as the Agency updates its technology but believes that training riders on the utilization of fare technology is not a substitute for equity-led fares media offerings and fare product accessibility.

As RTA expands eligibility criteria for its Priority Rider Program, RTA commits that all elements related to access for enrollment, sign-up, and utilization require specific review by the Board of Commissioners. RTA is committed to ensuring low barriers to entry to these programs.

9.0 Fare Validation

9.1 Fare Validation Requirements

Although RTA will not seek criminal punishments for fare evasion, passengers must purchase a fare (or confirm their eligibility for a free fare in accordance with Section 6.2) to board any RTA bus, streetcar, or ferry.

Prior to boarding an RTA bus, streetcar, or ferry, passengers must provide evidence of fare payment (or evidence of eligibility for a free fare in accordance with Section 6.2) to an Operator or Authorized Fare Validation Personnel.

Passengers must be able to provide evidence of fare payment (or evidence of eligibility for a free fare in accordance with Section 6.2) upon request from an Operator or Authorized Fare Validation Personnel at the following times:

- While on-board an RTA bus, streetcar, and ferries
- While in designated fare zones
- When exiting an RTA bus, streetcar, and ferries

Passengers eligible for a Youth Fare or Priority Rider Fare (as defined in Section 6.1) must have proof of eligibility for the use of such fare.

Passengers who are using a Youth Fare or Priority Rider Fare must be able to provide evidence of eligibility upon request from an Operator or Authorized Fare Validation Personnel while on-board an RTA bus, streetcar, or ferry.

10.0 Glossary of Terms

Adult	A fare category for all riders aged 19 to 64 years of age, or who do not otherwise meet the eligibility for 'Priority Rider' or 'Youth'
Authorized Fare Validation Personnel	Any RTA employee or contractor with the authority to check the presence and validity of a passenger's fare
Boarding Time	The time a vehicle spends at a scheduled stop for the purpose of passenger boarding
Bulk Discounts / Bulk Discount Program	Price reductions on fares when sold in quantities of 50 or more as defined in Section 7.2
Dwell Time	The time a vehicle spends at a scheduled stop without moving
Fare-Related Decisions	Internal RTA decisions or decisions made by the RTA Board of Commissioners associated with Fare-Related Elements
Fare Access Points	All points, geographical or otherwise, where passengers can purchase fares
Fare Elements	All components of the fare process, including but not limited to policy, pricing, fare media, technology, and service
Fare Free Days	Days on which no fares will be collected for RTA service
Fare Media	The physical or electronic means by which a fare purchase is represented
Fare Policy	This Fare Policy establishes transparent guidance for all Fare Elements and Fare-Related Decisions at RTA. The policy is technology and solution agnostic. It establishes RTA's goals, values, and commitments as it relates to fares
Fare Revenue	Money collected in exchange for fares
Fare Structure	The overall set of fares and prices offered to riders

Fare Structure Review	Requirements associated with review of the Fare Structure as defined in Section 5.1
Major Fare Technology Change	Change in the technology associated with the sale, validation, or enforcement of fares whereby the total capital cost associated with the improvements exceeds \$10 million
National Transit Database (NTD)	Database of financial, operating, and asset conditions of public transit providers, maintained by the Federal Transit Authority
New Orleans Regional Transit Authority (RTA)	Public transportation agency serving the New Orleans region
Operator	Employees and/or contractors responsible for the safe operation of RTA service vehicles
Priority Rider	<p>A fare category for all riders who meet one of the following eligibility criteria:</p> <ul style="list-style-type: none"> • (1) any person over 65 years of age. • (1) any person under 65 years of age registered legally blind by the Commission for the Blind; (2) any person under 65 years of age registered disabled by the Social Security Administration; (3) any person under 65 years of age certified 100% disabled by the Veterans Administration; (4) any persons under 65 years of age qualifying as Temporarily Disabled under criteria established by RTA, and so certified by a licensed physician; or (5) any persons certified by a licensed physician or health or social service professional to qualify for a Priority Rider fare. • (1) any person who is a Veteran of the United States Armed Forces • (1) any person who shows a valid Medicare Card
Retail Network	The collective retail partners who sell RTA passes

RTA Board of Commissioners	The governing body of the Regional Transit Authority, consisting of publicly appointed representatives from the communities served by RTA
Temporary Fare Structure	A fare structure implemented for less than six months
Time-Based Ticket	A fare that allows the holder to board multiple eligible RTA services within a given timeframe
Title VI and Environmental Justice Policy Manual	Title VI of the Civil Rights Act of 1964 protects people from discrimination based on race, color, and national origin to ensure nondiscriminatory transportation. The Title VI and Environmental Justice Policy Manual outlines RTA's commitments
Youth	A fare category for any rider who is under 19 years of age or who is a Kindergarten through Grade 12 student

11.0 FLOW CHART

N/A

12.0 REFERENCES

- Title VI and Environmental Justice Policy Manual (last revised October 15, 2020)
- Transportation Pass Policy (HC19)

13.0 ATTACHMENTS

N/A

14.0 PROCEDURE HISTORY

9/27/2022 Final Board approval granted

15.0 SPONSOR DEPARTMENT

General Administration



Board Report and Staff Summary

File #: 25-022

Finance Committee

Purchase of Canal and Riverfront Streetcar Tires

DESCRIPTION: This is a request to purchase steel tires for the streetcar lines	AGENDA NO: Click or tap here to enter text.
ACTION REQUEST: <input checked="" type="checkbox"/> Approval <input type="checkbox"/> Review Comment <input type="checkbox"/> Information Only <input type="checkbox"/> Other	

RECOMMENDATION:

Authorize the Chief Executive Officer to award a purchase order to Brookville Equipment Corporation for the purchasing of canal streetcar wheels with components in the amount not to exceed \$723,212.00.

ISSUE/BACKGROUND:

The Canal Street cars and 400 series cars utilize steel “tires” that allow them to run on the streetcar rails. Our maintenance teams perform preventive maintenance to ensure these tires are true by shaving off small portions of metal to ensure they are round and reduce any over-flanging that may occur. Like automotive tires, these tires need to be replaced as they wear down.

Currently, the agency needs to replace these tires, as many of our streetcar tires are nearing the point of replacement, and our stock count has run low. The agency has worked to find funding for these tires, and now that it has been identified, we need to place an order. These items are typically made to order and are not readily available on shelves or in stock like automotive tires.

DISCUSSION:

Tires for the Canal Street and 400 series streetcar wheel assemblies have been in use for over five years, and excessive wear has occurred. Wheel surfaces have been machined to the limits as per manufacturer specifications and are beyond any further tire truing, now requiring tire replacement.

In addition to the tires, resilient discs, associated bolts, locknuts, and washers are integral components of the entire 28” wheel assembly used on all the Canal Street and Riverfront streetcars. Each wheel assembly contains 1 tire, 16 resilient discs, 8 bolts, 8 locknuts, and 8 washers that are considered wear items and are required to be replaced when replacing steel tires.

Due to the wear condition on some of the existing Canal and Riverfront streetcars, maintenance will be replacing 44 tires with components. This is only a partial order for what we will end up needing over the next few years. Due to the high cost of these tires, the agency will only be able to do a partial order at this time and will work towards doing an order each year until the need is met. A total of 248 tires are ultimately needed for the fleet replacement.

FINANCIAL IMPACT:

Funding is available through local account 01-0000-00-1501-000-00-00000-00000, total estimated cost of this equipment is \$723,212.00 which will be funded by the accounts mentioned above.

NEXT STEPS:

When approved to proceed, the team will issue purchase order and notify Brookville Equipment Corporation to proceed.

ATTACHMENTS:

1. Resolution
2. Routing Sheet
3. Procurement Summary
4. Brookville Bid
5. AAR Manual of Standards
6. Cost Estimate

Prepared By: Floyd Bailey JR
Title: Director of Rail Maintenance

Reviewed By: Ryan Moser
Title: Chief Asset Management Officer

Reviewed By: Ronald Baptist
Title: Director of Procurement & Grants

Reviewed By: Gizelle Banks
Title: Chief Financial Officer



Lona Edwards Hankins
Chief Executive Officer

3/11/2025

Date



RESOLUTION NO. _____

FILE ID NO. 25-022

STATE OF LOUISIANA
PARISH OF ORLEANS

**AUTHORIZATION TO PURCHASE FROM BROOKVILLE EQUIPMENT CORPORATION
STREETCAR TIRES AND COMPONENTS**

Introduced by Commissioner _____, seconded by Commissioner _____.

WHEREAS, the Chief Executive Officer of the RTA has the need to purchase 40 streetcar tires with components; and

WHEREAS, the purchase of 40 streetcar tires and components will enable the RTA to effectively carry out its day to day operation; and

WHEREAS, RTA's Disadvantage Business Compliance Manager determined that there was no DBE goal set for this project; and

WHEREAS, staff evaluated all bids submitted and determined the price to be fair and reasonable; and

WHEREAS, it is the opinion of the RTA Board of Commissioners that purchasing 40 streetcar tires with components is critical to maintaining the function, reliability, and support of the Canal and Riverfront streetcar lines on behalf of the Regional Transit Authority; and

WHEREAS, funding shall not exceed **SEVEN HUNDRED TWENTY THREE THOUSAND TWO HUNDRED AND TWELVE DOLLARS (\$723,212.00)** for the above purchase is made available through **LOCAL FUNDING ACCOUNT 01-0000-00-1501-000-00-00-00000-00000**.

NOW, THEREFORE, BE IT RESOLVED that the Board of Commissioners of the Regional Transit Authority that the Chairman of the Board, or the designee, is authorized to issue a purchase order to Brookville Equipment Corporation for the purchase of streetcar ties and their component parts.

THE FOREGOING WAS READ IN FULL; THE ROLL WAS CALLED ON THE ADOPTION THEREOF AND RESULTED AS FOLLOWS:

YEAS: _____
NAYS: _____
ABSTAIN: _____
ABSENT: _____

AND THE RESOLUTION WAS ADOPTED ON THE 25TH DAY OF MARCH 2025.

**FRED A. NEAL, JR.
CHAIRMAN
RTA BOARD OF COMMISSIONERS**



EDITING: please Click the "Edit" bottom on very top left of this screen if you need to edit this sheet.

Request with ID: 215 it has been approved and thus not editable any longer. **Please do not delete it.**

REQUEST ID: 215

Mode: Final

Approval

Status:

Approved

Stage:

Document

Generated

Created By: BAILEY,
FLOYD JR Tue Oct 08
2024 22:12:29 GMT-
0500 (Central Daylight
Time)

Check to see rejection comments if any

Default Routing Review *

[Click to see full log](#)

EMAIL ROUTING ASSIGMENTS

Dir/Dept Head Personnel Lookup *

Floyd Bailey Jr

Dept Head Full Name

Floyd Bailey Jr

Dept Head RTA Email *

fbaileyjr@rtaforward.org

Info Tech Lookup

Info Tech Full Name

Info Tech Team

Info Tech RTA Email *

InfoTechProcurement@r

Grants Personnel Lookup

Grants Team

Dir Grants Rep Full Name

#Grants Team

Dir Grants RTA Email *

GrantsTeam@rtaforward.org

Budget Personnel Lookup

Budget Team

Budget Analyst Full Name

#Budget Team

Budget Analyst RTA Email *

Budget@rtaforward.org

Safety/Security Personnel
Lookup

Chief Safety Full Name

Chief Safety RTA Email *

Risk Personnel Lookup

Risk Analyst Full Name

Risk Analyst RTA Email *

SBE Personnel Lookup

Dir SBE Full Name

Dir SBE RTA Email *

DBE Personnel Lookup

DBE/EEO Compliance
Manager Name

DBE/EEO Compliance
Manager RTA Email *

Procurement Lookup

Dir Procurement Full Name

Dir Procurement RTA Email
*

Chief Lookup *

Chief Full Name

Chief RTA Email *

CFO Lookup

CFO Full Name

CFO RTA Email *

CEO Lookup

CEO Full Name

CEO RTA Email *

Department Representative

I have reviewed this form and the attachments provided and by signing below I give authority to the below stated Department Representative to proceed as lead in the procurement process.

DIRECTOR OF RAIL MAINTENANCE BAILEY, FLOYD JR fbaileyjr@rtaforward.org

Ext. *

8460

Name of project/service/product *

Canal/Riverfront Streetcar Wheel Change

Procurement Justification *

Tires for the Canal Street and Riverfront streetcar wheel assemblies have been in use for over five (5) years and excessive wear has occurred. Wheel surfaces have been machined to the limits as per manufacturer specifications and are beyond any further tire truing and now require tire replacement.

Besides the tires, resilient disc, associated bolts, locknuts and washers are integral components that are part of the entire 28" wheel assembly used on all the Canal Street and Riverfront streetcars. Each wheel assembly contains 1 tire, 16 resilient disc, 8 bolts, 8 locknuts and 8 washers that are considered wear items and are required to be replaced when replacing steel tires. Due to the wear condition on some of the existing Canal and Riverfront streetcars, Maintenance will be replacing 128 steel tires and referenced associated hardware.

Reason to justify the procurement of the product, project or services being requested.

Attachments

(*Indicated Required Items)

Project Schedule

ICE Amount *

Technical Specs

Scope of work

Delivery Date *

\$ 620,682.15

Yes



Yes

Jan 2, 2025

No

No

ICE FORM ATTACHMENT IS REQUIRED TO CONTINUE...! *

-  ICE Wheels.pdf
-  .pdf

TECHNICAL SPECS ATTACHMENT IS REQUIRED...! *

-  Wheel Tech Specs.pdf



AAR_Manual_of_Standards.pdf



APTA-PR-M-S-019-17.pdf



APTA-PR-M-S-012-99.pdf

SCOPE OF WORK ATTACHMENT IS REQUIRED...! *



Canal and Riverfront Streetcar Wheel Scope of Work.docx

Capital Project ID

Capital projects review required?

Project ID *

Canal/Riverfront Streetcar Wheel Change

Capital Project Review by *

Rafe Rabalais

Capital projects full name

Rafe Rabalais

Capital project RTA email

rrabalais@rtaforward.org

Funding Source

Funding Type *

Federal State Local Other

Budget Analyst

#BUDGET TEAM

Available Federal funding

\$

Available State Funding

\$

Available Local Funding *

\$ 750,000.00

Available Other Funding

\$

Projected Federal Cost

\$

Projected State Cost

\$

Projected Local Cost *

\$ 620,682.12

Projected Other Cost

\$

Total Available Funding

\$ 750,000.00

Projected Total Cost

\$ 620,682.12

ICE Amount Entered

\$ 620,682.15

Need to Input Multi-Year Breakdown (Only applies to State+Local+Other)?



No

Budget

Note: The default "Budget Team" includes all budget analysts. They will all get an email, but only one will approve according to the budget code assignment.

Budget lookup List-1 *

01-0000-00-1501-000-00-00-000000-000...

Budget code-1 Selected

01-0000-00-1501-000-00-00-000000-0000C

Budget lookup List-2

Budget code-2 Selected

Budget lookup List-3

Budget code-3 Selected

Budget lookup List-4

Budget code-4 Selected

Budget lookup List-5

Budget code-5 Selected

Safety, Security and Emergency Management - Review and Approval is required

Safety Review and Approval is Required

Safety Chief

MICHAEL J. SMITH



Yes

Safety Attachments

No files uploaded

Risk Management - Review and Approval is required

STD Insurance Provisions is Required



Yes

Risk Management Analyst

MICHAEL J. SMITH

Risk Attachments

No files uploaded

DBE / SBE Goal - Review and Approval is required

Director of Small Business Development

ADONIS CHARLES EXPOSE'

DBE/EEO Compliance Manager

ADONIS CHARLES EXPOSE'

I have reviewed this form and the attachments provided and by inputting my name below I give authority to the above stated department representative to proceed as lead in the procurement process.

Input your fullname *

Floyd Bailey Jr

Date *

Oct 8, 2024

PROCUREMENT SUMMARY-IFB 2024-040

REQUIREMENTS

A Solicit Request Routing Sheet for Streetcar Wheels with attached scope of work was received by Procurement from automated procurement system on October 22, 2024.

There was a no DBE goal for this solicitation.

Procurement Policy:

The Independent Cost Estimate for this procurement is \$620,682.12 for 44 streetcar wheels, which exceeds the Small Purchase threshold of \$25,000 therefore in compliance with the Regional Transit Authority of New Orleans Procurement Policies and Procedures Manual, Section VII.B. This procurement shall be conducted through formal advertisement (competitive means).

Procurement Method:

More than one responsive and responsible offeror can meet the solicitation requirements. Specifications furnished by the user department are complete, adequate, precise and realistic. No discussions or negotiations will be needed to address technical requirements, award will be made on lowest responsible/responsive bidder. Therefore, the IFB method of solicitation is selected as the method of procurement.

SOLICITATION

Invitation for Bids (IFB) No. 2024-040 Public Notice was published in the The Advocate. The Public Notice and the IFB 2023-040 were posted on the RTA website beginning December 12, 2024. The IFB submittal deadline was January 15, 2025 at 11:00 am cst.

IFB SUBMITTAL

Bid Opening was held on 1/15/2025 at 11:00 am. Briana Howze handled the receipt of all submissions received. Two (2) bids were received.

DETERMINATION

Two (2) bids were determined responsive and provided all required documents.

SUBMITTAL ANALYSIS

Brookville Equipment Corporation	\$737,712.80
Penn Machine Company	\$742,236.00

SUMMARY

A budget of \$750,000.00 was approved through the budget department. Based on the information above the Bids received were prepared and sent to Procurement Director for further review. An Administrative Review Form was prepared by Briana Howze – Contract Administrator.

Procurement Department: Recommend award be made to lowest responsive/responsible bidder, Brookville Equipment Corporation is the lowest responsible bidder. It is in the best interest of RTA to award this bid to Brookville Equipment Corporation. I recommend this bid be awarded to Brookville Equipment Corporation for 44 streetcar wheels.

BUY AMERICA

CERTIFICATE OF COMPLIANCE WITH SECTION 165(a)

The bidder or proposer hereby certifies that it will comply with the requirements of section 165(a) of the Surface Transportation Assistance Act of 1982, as amended, and the applicable regulations in 49 CFR part 661.

Date 1/13/25

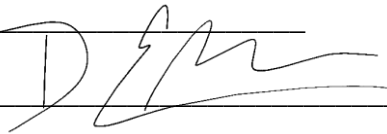
Signature 

Company Name Brookville Equipment Corp

Title Parts Sales Account Manager

RTA Project No. IFB 2024-040



CERTIFICATE OF LIABILITY INSURANCE

DATE (MM/DD/YYYY)
2/21/2023

THIS CERTIFICATE IS ISSUED AS A MATTER OF INFORMATION ONLY AND CONFERS NO RIGHTS UPON THE CERTIFICATE HOLDER. THIS CERTIFICATE DOES NOT AFFIRMATIVELY OR NEGATIVELY AMEND, EXTEND OR ALTER THE COVERAGE AFFORDED BY THE POLICIES BELOW. THIS CERTIFICATE OF INSURANCE DOES NOT CONSTITUTE A CONTRACT BETWEEN THE ISSUING INSURER(S), AUTHORIZED REPRESENTATIVE OR PRODUCER, AND THE CERTIFICATE HOLDER.

IMPORTANT: If the certificate holder is an ADDITIONAL INSURED, the policy(ies) must have ADDITIONAL INSURED provisions or be endorsed. If SUBROGATION IS WAIVED, subject to the terms and conditions of the policy, certain policies may require an endorsement. A statement on this certificate does not confer any rights to the certificate holder in lieu of such endorsement(s).

PRODUCER USI Insurance Services, LLC Six PPG Place, Suite 200 Pittsburgh, PA 15222 412 765-3510		CONTACT NAME: James M Malarkey
		PHONE (A/C, No, Ext): 412 765-3510
INSURED Brookville Equipment Corp. 175 Evans Street Brookville, PA 15825		INSURER(S) AFFORDING COVERAGE
		INSURER A : Travelers Property Cas. Co. of America
		INSURER B : AXIS Insurance Company
		INSURER C : BrickStreet Mutual Insurance Company
		INSURER D : Argonaut Insurance Company
		INSURER E :
		INSURER F :

COVERAGES CERTIFICATE NUMBER: REVISION NUMBER:

THIS IS TO CERTIFY THAT THE POLICIES OF INSURANCE LISTED BELOW HAVE BEEN ISSUED TO THE INSURED NAMED ABOVE FOR THE POLICY PERIOD INDICATED. NOTWITHSTANDING ANY REQUIREMENT, TERM OR CONDITION OF ANY CONTRACT OR OTHER DOCUMENT WITH RESPECT TO WHICH THIS CERTIFICATE MAY BE ISSUED OR MAY PERTAIN, THE INSURANCE AFFORDED BY THE POLICIES DESCRIBED HEREIN IS SUBJECT TO ALL THE TERMS, EXCLUSIONS AND CONDITIONS OF SUCH POLICIES. LIMITS SHOWN MAY HAVE BEEN REDUCED BY PAID CLAIMS.

INSR LTR	TYPE OF INSURANCE	ADDL INSR	SUBR WVD	POLICY NUMBER	POLICY EFF (MM/DD/YYYY)	POLICY EXP (MM/DD/YYYY)	LIMITS
A	<input checked="" type="checkbox"/> COMMERCIAL GENERAL LIABILITY <input type="checkbox"/> CLAIMS-MADE <input checked="" type="checkbox"/> OCCUR GEN'L AGGREGATE LIMIT APPLIES PER: <input type="checkbox"/> POLICY <input type="checkbox"/> PRO-JECT <input type="checkbox"/> LOC OTHER:			Y6309N00133ATIL22	09/30/2022	09/30/2023	EACH OCCURRENCE \$ 1,000,000 DAMAGE TO RENTED PREMISES (Ea occurrence) \$ 1,000,000 MED EXP (Any one person) \$ 5,000 PERSONAL & ADV INJURY \$ 1,000,000 GENERAL AGGREGATE \$ 2,000,000 PRODUCTS - COMP/OP AGG \$ 2,000,000 \$
A	<input checked="" type="checkbox"/> AUTOMOBILE LIABILITY <input checked="" type="checkbox"/> ANY AUTO OWNED AUTOS ONLY <input checked="" type="checkbox"/> HIRED AUTOS ONLY <input type="checkbox"/> SCHEDULED AUTOS NON-OWNED AUTOS ONLY			8109N42894A2214G	09/30/2022	09/30/2023	COMBINED SINGLE LIMIT (Ea accident) \$ 1,000,000 BODILY INJURY (Per person) \$ BODILY INJURY (Per accident) \$ PROPERTY DAMAGE (Per accident) \$ \$
B	<input checked="" type="checkbox"/> UMBRELLA LIAB <input checked="" type="checkbox"/> OCCUR <input type="checkbox"/> EXCESS LIAB <input type="checkbox"/> CLAIMS-MADE DED RETENTION \$			P00100021667704	09/30/2022	09/30/2023	EACH OCCURRENCE \$ 5,000,000 AGGREGATE \$ 5,000,000 \$
C	WORKERS COMPENSATION AND EMPLOYERS' LIABILITY ANY PROPRIETOR/PARTNER/EXECUTIVE/OFFICER/MEMBER EXCLUDED? Y/N <input checked="" type="checkbox"/> N (Mandatory in NH) If yes, describe under DESCRIPTION OF OPERATIONS below		N/A	WCB1025775	09/30/2022	09/30/2023	<input checked="" type="checkbox"/> PER STATUTE <input type="checkbox"/> OTH-ER E.L. EACH ACCIDENT \$ 500,000 E.L. DISEASE - EA EMPLOYEE \$ 500,000 E.L. DISEASE - POLICY LIMIT \$ 500,000

DESCRIPTION OF OPERATIONS / LOCATIONS / VEHICLES (ACORD 101, Additional Remarks Schedule, may be attached if more space is required)
**** Workers Comp Information****
D WC928788479944 Eff Date 09/30/2022 Exp. Date 09/30/2023
WC Each Accident Limit: \$500,000
WC Policy Limit: \$500,000
WC Each Employee Limit: \$500,000
(See Attached Descriptions)

CERTIFICATE HOLDER New Orleans Regional Transit Authority 2817 Canal Street New Orleans, LA 70119	CANCELLATION SHOULD ANY OF THE ABOVE DESCRIBED POLICIES BE CANCELLED BEFORE THE EXPIRATION DATE THEREOF, NOTICE WILL BE DELIVERED IN ACCORDANCE WITH THE POLICY PROVISIONS. AUTHORIZED REPRESENTATIVE
---	--

DESCRIPTIONS (Continued from Page 1)

Evidence of Coverage

**CERTIFICATION ON PRIMARY PARTICIPANT
REGARDING DEBARMENT, SUSPENSION, AND
OTHER RESPONSIBILITY MATTERS**

The Primary Participant (Potential Contractor for a major third party contract), certifies to the best of its knowledge and belief, that it and its principles:

1. Are not presently debarred, suspended, proposed for debarment, declared ineligible, or voluntarily excluded from covered transactions by any Federal Department or agency;
2. Have not within a three-year period preceding this proposal been convicted of or had a civil judgment rendered against them for commission of fraud or a criminal offense in connection with obtaining, attempting to obtain, or performing a public (federal, State, or local) transaction; violation of Federal or State antitrust statutes or commission of embezzlement, theft, forgery, bribery, falsification or destruction of records, making false statements, or receiving stolen property;
3. Are not presently indicted for or otherwise criminally or civilly charged by a government entity (Federal, State, or local) with commission of any of the offenses enumerated in paragraph (2) of this certification; and
4. Have not within a three-year period preceding this application/proposal had one or more public transactions (Federal, State or local) terminated for cause or default.

(If the primary participant is unable to certify to any of the statements I this certification, the participants shall attach an explanation to this certification.)

THE PRIMARY PARTICIPANT, (POTENTIAL CONTRACTOR FOR A MAJOR THIRD PARTY CONTRACT, CERTIFIES OR AFFIRMS THAT TRUTHFULNESS AND ACCURACY OF THE CONTENTS OF THE STATEMENTS SUBMITTED ON OR WITH THIS CERTIFICATION AND UNDERSTANDS THAT THE PROVISIONS OF 31 U.S.C. SECTION 3801 ET SEQ ARE APPLICABLE HERETO.

COMPANY Brookville Equipment Corp

ADDRESS 175 Evans St. Brookville, Pa 15825

DATE 1/13/25

Signature of Offeror's Authorized Representative

**CERTIFICATION REGARDING DEBARMENT
SUSPENSION, INELIGIBILITY AND VOLUNTARY
EXCLUSION - LOWER TIER COVERED TRANSACTION**

- 1. The prospective lower tier participant certifies, by submission of this offer, that neither it nor its principals is presently debarred, suspended, proposed for debarment, declared ineligible, or voluntarily excluded from participation in this transaction by any Federal department or agency.**
- 2. Where the prospective lower tier participant is unable to certify to any of the statements in this certification, such prospective participants shall attach an explanation to this offer.**
- 3. The Lower-Tier participant (Potential Contractor under a major Third Party Contract), certifies or affirms the truthfulness and accuracy of the contents of the statements submitted on or with this certification and understands that the provisions of 31 U.S.C., 3801 ET SEQ are applicable thereto.**

COMPANY Brookville Equipment Corp

ADDRESS 175 Evans St. Brookville, Pa 15825

DATE 1/13/25

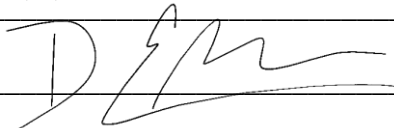

Signature of Offeror's Authorized Representative

PUBLIC NOTICE

REGIONAL TRANSIT AUTHORITY CANAL/RIVERFRONT STREETCAR WHEEL CHANGE INVITATION FOR BID (IFB) # 2024-040

Project Description: The Regional Transit Authority of New Orleans invites qualified vendors to provide Canal/Riverfront Streetcar Wheel Change per specifications in IFB 2024-040.

How to obtain a copy of the IFB: Specifications and further information concerning the IFB may be obtained December 12, 2024 from the RTA's Procurement website at <https://norta.procurement.com/home>. If you are not already registered, you will be required to first register on this website. The IFB can also be obtained at Regional Transit Authority's website at <http://www.norta.com> and at 2817 Canal Street, New Orleans, LA 70119.

Responding to IFB: Bids shall be submitted thru the RTA's Procurement website on or before January 15, 2025, 11:00 AM.

A Bid Opening will be held in the RTA Boardroom on Wednesday, January 15, 2025, at 11:00 AM. Any questions or further information concerning the IFB may be submitted Via <https://norta.procurement.com/home>, beginning on December 12, 2025.

RTA in accordance with 49 Code of Federal Regulations (CFR) Part 26 has an obligation to ensure nondiscrimination of Disadvantaged Business Enterprises (DBEs) and to comply with all federal, state and local regulations relative to utilization of DBEs on publicly funded projects. The RTA is committed to utilization of DBEs on all federally funded projects toward attainment of the agency's established overall goal of 32%. A specific DBE goal **has not been** established for this project as there are no subcontracting opportunities on this project.

Notice to all offerors is hereby provided that in accordance with all applicable federal, state and local laws the RTA will ensure that DBEs are afforded full opportunity to submit offers and responses to this solicitation and to participate in any contract consummated pursuant to this advertisement. Additionally, no offeror will be discriminated against on the basis of age, sex, race, color, religion, national origin, ethnicity or disability.

The RTA reserves the right to accept or reject any and all submittals.

Lona Hankins
Interim Chief Executive Officer
Regional Transit Authority

INVITATION FOR BIDS
FROM
REGIONAL TRANSIT AUTHORITY

SUBJECT: Canal/Riverfront Streetcar Wheel Change

DATE: December 12, 2024

INVITATION
FOR BIDS NO. 2024-040

BID OPENING: Wednesday, January 15, 2025 11:00 AM

The Regional Transit Authority invites bids for supplies and/or services set forth above in accordance with the specifications enclosed herewith.

Bids MUST be received at the RTA Office by the date and time set for bid opening.

Enclosures ("X" indicates item enclosed)

- | | | | |
|----------|-----------------------------|----------|----------|
| <u>X</u> | Public Notice to Bidders | <u>X</u> | Bid Form |
| <u>X</u> | Bidder Submission Checklist | | |
| <u>X</u> | Instruction to Bidders | | |
| <u>X</u> | General Provisions | | |
| <u>X</u> | Technical Specifications | | |

BIDDER SUBMISSION CHECKLIST

The following items must be submitted in order to be considered responsive and are due on the bid submittal date.

Louisiana Uniform Public Work Bid Form (Attachment II)

Certificate on Primary Debarment

Buy America Certificate for Compliance or Buy America Certificate for Non-Compliance

Non-Collusion Affidavit

Certificate Regarding Debarment– Lower Tier

Certification of Restrictions on Lobbying

Participant Information Form

Certificates of Insurance

INSTRUCTIONS FOR OBTAINING FORMS

Go to RTA’s official web site at:

[New Orleans Regional Transit Authority - Procurements and Contracts \(norta.com\)](http://norta.com)

Click on “Vendor Form Library”

TABLE OF CONTENTS

I.	INSTRUCTIONS TO BIDDERS	PAGE NUMBER
1.1	Scope	1
1.2	Contract Documentation	1
1.3	Bid Requirements	1
1.4	Pricing	1
1.5	Brand Names	2
1.6	Qualifications For Award	3
1.7	Bidder Review Procedures	4
1.8	Bid Preparation	5
1.9	Bid Postponement and Amendment	5
1.10	Cancellation of the Invitation For Bids	5
1.11	Public Bid Opening	5
1.12	Bid Rejection	6
1.13	Single Bid Response	6
1.14	Bid Withdrawal	6
1.15	Award Procedure	6
1.16	Utilization of Minority and Women Owned Banks	6
1.17	Addenda	7
II.	GENERAL PROVISIONS	
2.1	Written Change Orders/Amendments	8
2.2	Change Order/Amendment Procedure	8
2.3	Omissions	8
2.4	Priority	8
2.5	Communications	8
2.6	Interests of Members of, or Delegates to Congress	9
2.7	Conflict of Interest	9
2.8	Equal Employment Opportunity	9
2.9	Privacy Requirements	9
2.10	Indemnification	10
2.11	Performance	11
2.12	Status of Contractor and Its Employees	11
2.13	Insurances and Licenses	11
2.14	Subcontractors	11
2.15	Assumption of Risk of Loss	11
2.16	Shipping	12
2.17	Delivery	12
2.18	Certificate of Conformance	12
2.19	Acceptance	12
2.20	Quality Inspection	12
2.21	Correction by Contractor	13
2.22	Materials/Accessories Responsibility	13
2.23	Unavoidable Delays	13
2.24	Notification of Delay	13
2.25	Request for Extension	13
2.26	Access Requirements for Individuals with Disabilities	14
2.27	Application of Federal, State and Local Laws and Regulations	15
2.28	Contract Period	15

2.29	No Obligation by the Federal Government	15
2.30	Federal Changes	15
2.31	Incorporation of Federal Transit Administration (FTA) Terms	16
2.32	Exclusionary or Discriminatory Specifications	16
2.33	Geographic Restrictions	16
2.34	Prompt Payment	16
2.35	Confidentiality	17
2.36	Disputes	18
2.37	Ownership of Documents	18
2.38	State and Local Law Disclaimer	19
2.39	Participant Information	19
2.40	Non-Collusion Affidavit	19
2.41	Regional Transit Authority General Provisions	19

III. FEDERAL REQUIREMENTS

3.1	Access to Records	20
3.2	Buy America Requirements	21
3.3	Pre-Award And Post-Delivery Audits	21
3.4	Cargo Preference Requirement	21
3.5	Clean Air Act And Federal Water Pollution Control Act	22
3.6	Civil Rights Laws And Regulations	23
3.7	Disadvantaged Business Enterprise (DBE)	24
3.8	Employee Protections	25
3.9	Energy Conservation	26
3.10	Fly America	26
3.11	Government-Wide Debarment And Suspension	27
3.12	Lobbying Restrictions	28
3.13	No Government Obligation To Third Parties	28
3.14	Patent Rights And Rights In Data	29
3.15	Program Fraud And False Or Fraudulent Statements & Related Acts	30
3.16	Recycled Products	30
3.17	Substance Abuse Requirements	30
3.18	Termination	31

ATTACHMENTS

Technical Specifications – Attachment I
 LA Uniform Public Work Bid Form – Attachment II

I INSTRUCTIONS TO BIDDERS

1.1 SCOPE

Contractor shall provide Streetcar Wheel Change. The contract awarded pursuant to this Invitation for Bids shall be a fixed price contract.

1.2 CONTRACT DOCUMENTATION

Any contract resulting from this solicitation shall contain the terms and conditions included in this Invitation for Bids and any addenda issued pursuant hereto.

1.3 BID REQUIREMENTS (ELECTRONIC BID SUBMITTAL)

Electronic bids will be uploaded through our electronic bidding system at <https://norta.procureware.com/home>. Hard copy bids will be accepted upon request as one original only to be hand delivered or mailed to the RTA's Procurement Office located at 2817 Canal St, New Orleans, LA 70119 no later than the exact time and date specified in this Invitation for Bids. Bids received after the date and time shall be considered late. All necessary and appropriate resources, including but not limited to labor, equipment, and materials, supplies, etc. shall be furnished in strict accordance with the project schedule and terms and conditions contained in this Invitation for Bids.

1.4 PRICING

The bidder shall complete and execute the Louisiana Uniform Public Work Bid Form (Attachment II). The bidder shall quote prices in the unit of measure specified and shall include all applicable taxes in the bid price. The RTA is exempt from all taxes; however, only Louisiana State Sales Tax Exemption for materials incorporated into the final product will be transferable to the Contractor. The Contractor shall pay all other sales, use, and other similar taxes that are enacted as of the Contract execution or subsequently revised or added. The Regional Transit Authority will pay no sales taxes or for any increase in sales taxes, unless such increase in sales tax is due to a change in the interpretation of the Louisiana Tax Code by the Louisiana State Tax Commission and such increase in sales tax is the subject of an authorized change order. Whenever there is a discrepancy between a unit price and any extension, the unit price shall govern. Bidders are hereby notified that discount terms shall not be used in the determination of award of this contract.

1.5 BRAND NAMES

Wherever in the specifications the name of a certain brand, make, manufacturer, or definite specification is utilized, these specifications are used only to denote the quality standard

of product, style type, and character of product desired and do not restrict bidders to the specific brand, make, manufacturer or specification named.

1.6 QUALIFICATIONS FOR AWARD

Award of this contract shall be made to the lowest responsible bidder, provided the bid is responsive in all respects to the terms and conditions of the contract, and the requirements, conditions, specifications as provided in this Invitation for Bids. To be responsible the Contractor shall be a person, firm, or corporation that:

Has in operation, or has the capability to have in operation, or has access to a manufacturing plant adequate to ensure delivery of all services, goods and supplies within the time specified under this contract.

Has adequate engineering and service personnel, or has the capability to obtain such personnel, to satisfy any engineering or service problems that may arise during the contract period.

Has adequate construction management and construction craft personnel, or has the capability to obtain such personnel, to satisfy any construction or service problems that may arise during the contract period.

Has the necessary facilities and financial resources, or has the capability to obtain such facilities and financial resources, to complete the contract in a satisfactory manner within the required time.

The RTA shall have the right to conduct a pre-award survey of each bidder and to conduct a cost/price analysis and/or audit to determine if the prices bid are fair and reasonable.

1.7 BIDDER REVIEW PROCEDURES

FOR THE PURPOSES OF THIS PARAGRAPH, SUBMISSION DEADLINES SHALL BE 11:00 AM. (CENTRAL TIME).

a. Request for Modification or Clarification

This section establishes procedures for bidders to seek review of this Invitation for Bids and any addenda. A bidder may discuss this Invitation for Bids and any addenda with the RTA. Such discussions do not, however, relieve bidders from the responsibility of submitting written, documented requests. Bidders may submit to the RTA requests for interpretations, clarifications or modifications concerning any term, condition and/or specification included in this Invitation for Bids and/or in any addendum hereto. Any such request, questions, etc. must be received by the RTA, in writing. RTA will entertain questions etc. submitted at the pre-bid conference on the attached pre-bid conference form, or requests submitted in writing not less than seven (7) calendar days before the date of scheduled bid opening. All requests must be accompanied by all relevant information supporting the request for modification, interpretation, clarification or addendum of this solicitation. All requests for clarification and/ or modification should be submitted through the RTA Procurement website at <https://norta.procureware.com/home>.

RTA will issue a written determination relative to each request made pursuant to this procedure. The written determination must be posted for all bidders to view through the E-Bid website or otherwise furnished to all bidders at least three (3) calendar days (72 hours) before the date scheduled as the bid opening date.

b. Protest Procedures

The following is an explanation of the RTA protest procedures which must be followed completely before all administrative remedies are exhausted.

Any person who is aggrieved in connection with the solicitation or award of a contract may protest to the Director of Procurement. Protests shall be submitted in writing specifically identifying the area of protest and containing any support data, test results, or other pertinent information substantiating the appeal. A protest with respect to a solicitation must be submitted in writing to the RTA at least five (5) calendar days prior to bid opening. A protest with regard to contract award shall be submitted, in writing, within seven (7) calendar days after award of the contract.

Prior to any action in court, the Director of Procurement shall have the authority to settle or resolve a protest from an aggrieved person concerning the solicitation or award of a contract.

If the protest is not resolved by mutual agreement, the Director of Procurement or his designee shall within thirty (30) calendar days of protest issue a decision in writing. The decision shall:

1. State the reasons for the action taken; and
2. Inform the protestor of his/her right to administrative review.

A copy of this decision shall be mailed or otherwise furnished immediately to the protestant and any other party intervening. This decision shall be final and conclusive unless:

1. The decision is fraudulent; or
2. The person adversely affected by the decision has submitted a timely administrative appeal to the CEO - RTA.

In the event of a timely protest under these regulations, the RTA shall not proceed further with the solicitation or with the award of the contract unless the Director of Procurement makes a written determination that the award of the contract is necessary without delay to protect the substantial interests of the RTA.

The CEO-RTA shall have the authority to review and determine any appeal by an aggrieved person from a determination by the Director of Procurement or his designee. The aggrieved person must file an appeal within seven (7) calendar days of receipt of a decision from the Director of Procurement.

On any appeal of the decision of the Director of Procurement, the CEO-RTA shall decide within thirty (30) calendar days whether the solicitation or award was made in accordance with the constitution, statutes, regulations, and the terms and conditions of the

solicitation. Any prior determination by the Director of Procurement or his designee shall not be final or conclusive.

A copy of the CEO-RTA decision shall be mailed or otherwise furnished immediately to the protestant or any other party intervening. The decision of the CEO-RTA shall be final and conclusive unless:

1. The decision is fraudulent; or
2. The person adversely affected by the decision has timely appealed to FTA after having exhausted the local protest procedures stated above.

The RTA reserves the right to designate any person(s) other than CEO-RTA or the Director of Procurement to perform the duties provided for in this Paragraph.

Any appeal to FTA under these protest procedures will be made pursuant to FTA Circular 4220.1F, as amended.

1.8 BID PREPARATION

Each offer shall be made on the Invitation for Bids Form which shall be enclosed in a sealed envelope with the name and address of the bidder, the required contractor's licensing number, the advertised date and time of the bid opening, and the title of the bid marked on the outside. All blank spaces on the bid form must be filled in and no changes shall be made in the wording. Bidder's wishing to submit an electronic bid are directed to, Section I. Instruction to Bidder's, Paragraph 1.3 BID REQUIREMENTS (ELECTRONIC BID SUBMITTAL) of this IFB.

1.9 BID POSTPONEMENT AND AMENDMENT

The RTA reserves the right to amend the instructions, general conditions, special conditions, plans, scope of work, and specifications of this solicitation up to the time set for bid opening. Copies of such amendments shall be furnished to all prospective bidders.

1.10 CANCELLATION OF THE INVITATION FOR BIDS

The RTA reserves the right to cancel this Invitation for Bids in whole or in part upon written determination by the Director of Procurement that such cancellation is in the best interest of the RTA.

1.11 PUBLIC BID OPENING

Bids shall be publicly opened at the time specified herein. The content of all bids, including documents marked proprietary, shall be made public for the information of bidders and other interested parties. Bidders are required to submit all administrative submittals, including SBE Forms. This does not supersede the requirement for a fully executed Invitation for Bid LA Public Bid Form, note Attachment II, at the time of the Bid Opening.

1.12 BID REJECTION

The RTA reserves the right to waive any minor informality or irregularities in the bids received which do not prejudice other bidders. The RTA also reserves the right to reject any and all bids in whole or in part, and to award by items, parts of items, or by any group of items specified. Conditional bids, or those which take exception to the specifications, shall be considered non-responsive and shall be rejected.

1.13 SINGLE BID RESPONSE

If only one bid is received in response to this Invitation for Bids, a detailed cost proposal may be requested of the single bidder. A cost/price analysis and evaluation and/or audit may be performed in order to determine if the price is fair and reasonable. Award of a contract to the bidder submitting the only bid received in response to this Invitation for Bids may be subject to approval by the FTA.

1.14 BID WITHDRAWAL

Prior to the date and time set for bid opening, bids may be modified or withdrawn by the bidder's authorized representative in person, or by written or telegraphic notice. After the bid opening, bids may not be withdrawn for ninety (90) calendar days.

1.15 AWARD PROCEDURE

Within a reasonable time after the bid opening, the RTA will transmit the contract documents to the successful bidder. The contract documents will, at a minimum, consist of this Invitation for Bids, the Contractor's bid, RTA's standard contract provisions and provisions required by FTA.

1.16 UTILIZATION OF MINORITY AND WOMEN OWNED BANKS

All bidders are hereby encouraged to utilize the services of minority and women owned banks. The RTA's DBE Specialist is knowledgeable about such services. Any questions or concerns should be directed to the DBE Specialist at RTA's offices, 2817 Canal St., New Orleans, LA. (504) 827-8308

1.17 ADDENDA

Bidders shall acknowledge receipt of all addenda to this Invitation for Bids. Acknowledge receipt of each addendum must be clearly established and included with offer. The undersigned acknowledges receipt of the following addenda.

Addendum No. _____, dated _____
Addendum No. _____, dated _____
Addendum No. _____, dated _____

IFB NO. 2024-040

A handwritten signature in black ink, consisting of a large capital 'D' followed by a stylized, cursive 'E' and a horizontal line extending to the right.

Company Name

Company Representative

II. GENERAL PROVISIONS

2.1 WRITTEN CHANGE ORDERS/AMENDMENTS

This contract may be changed/ amended in any particular allowed by law upon the written mutual agreement of both parties.

2.2 CHANGE ORDER/AMENDMENT PROCEDURE

Within ten (10) calendar days after receipt of the written change order to modify the contract, the Contractor shall submit to the RTA a detailed price and schedule proposal for the work to be performed. This proposal shall be accepted or modified by negotiations between the Contractor and the RTA. At that time, a detailed modification shall be executed in writing by both parties. In the event that federal funds are used in this procurement, the FTA may reserve the right to concur in any change order or any dispute arising under such change order. Disagreements that cannot be resolved by negotiation shall be resolved in accordance with the contract disputes clauses. Regardless of any disputes, the Contractor shall proceed with the work ordered, if the RTA has obtained the concurrence of FTA, should such concurrence be required. Regardless of any other requirement herein, RTA shall negotiate profit as a separate element of cost for any change order or amendment to any contract awarded pursuant to this solicitation.

2.3 OMISSIONS

Notwithstanding the provision of drawings, technical specifications or other data by the RTA, the Contractor shall supply all resources and details required to make the supplies complete and ready for utilization even though such details may not be specifically mentioned in the drawings and specifications.

2.4 PRIORITY

In the event of any conflicts between the description of the supplies and/or services in the Technical Specifications and drawings and other parts of this Invitation for Bids, the Technical Specifications and drawings shall govern.

2.5 COMMUNICATIONS

All official communications in connection with this contract shall be in writing. Respondents to this solicitation or persons acting on their behalf may not contact, between the release of the solicitation and award, any employee or officer of the Regional Transit Authority, including the Board of Commissioners, concerning any aspect of this solicitation, except in writing to the procurement officer or as provided in the solicitation documents. Violation of this provision may be grounds for rejecting a response.

2.6 INTEREST OF MEMBERS OF, OR DELEGATES TO CONGRESS

In accordance with 18 U.S.C. Subsection 431, no member of, or delegates to, the Congress of the United States shall be admitted to a share or part of this contract or to any benefit arising there from.

2.7 CONFLICT OF INTEREST

No Board Member, employee, officer or agent, or employee of such agent of the RTA shall participate in the selection or in the award or administration of a contract if a conflict of interest, real or apparent, would be involved. Such a conflict would arise when:

- a. The Board Member, employee, officer or agent, or employee of such agent;
- b. Any member of his immediate family;
- c. His or her partner; or
- d. An organization that employs, or is about to employ any of the above, has a direct or indirect, present or future financial or other interest in the firm selected for award.

The RTA's Board Members, officers, employees or agents shall neither solicit nor accept gratuities, favors or anything of monetary value from contractors, potential contractors or parties of sub agreements.

Each entity that enters into a contract with the RTA is required, prior to entering into such contract, to inform the RTA of any real or apparent organizational conflicts of interest. An organizational conflict of interest exists when the contractor is unable or potentially unable to provide objective assistance or advice to the RTA due to other activities, relationships, contracts, or circumstances; when the contractor has an unfair competitive advantage through obtaining access to nonpublic information during the performance of an earlier contract; and during the conduct of an earlier procurement, the contractor has established the ground rules for a future procurement by developing specifications, evaluation factors, or similar documents, in accordance with Chapter VI, 2.a.(4)(h) of FTA C 4220.1F.

2.8 EQUAL EMPLOYMENT OPPORTUNITY

The Contractor shall comply with Executive Order No. 11246 as amended, entitled "Equal Employment Opportunity" as supplemented in Department of Labor Regulations (41 C.F.R. Paragraph 60). In connection with the execution of this Agreement, the Contractor shall not discriminate against any employees or applicant for employment because of race, religion, color, sex, age, or national origin. The Contractor shall take affirmative action to ensure that applicants are employed and that employees are treated during their employment without regard to their race, religion, color, sex, age, or national origin. Such actions shall include, but not be limited to, the following: employment, upgrading, demotion, or transfer, recruitment or recruitment advertising; layoff or termination, rates of pay or other forms of compensation, and selection for training, including apprenticeship. Contractor further agrees to insert a similar provision in all subcontracts, except subcontracts for standard commercial supplies or raw materials.

2.9 PRIVACY REQUIREMENTS

The following requirements apply to the Contractor and its employees that administer any system of records on behalf of the Federal Government under any contract:

(1) The Contractor agrees to comply with, and assures the compliance of its employees with, the information restrictions and other applicable requirements of the Privacy Act of 1974, 5 U.S.C. § 552a. Among other things, the Contractor agrees to obtain the express consent of the Federal Government before the Contractor or its employees operate a system of records on behalf of the Federal Government. The Contractor understand that the requirements of the Privacy Act, including the civil and criminal penalties for violation of that Act, apply to those individuals involved, and that failure to comply with the terms of the Privacy Act may result in termination of the underlying contract.

(2) The Contractor also agrees to include these requirements in each subcontract to administer any system of records on behalf of the Federal Government financed in whole or in part with Federal assistance provided by FTA.

2.10 INDEMNIFICATION

The Contractor covenants and agrees to fully defend, protect, indemnify and hold harmless the RTA, their directors, officers, employees, agents, and assigns from and against all liability, including strict liability, claims, demands, and causes of action brought by others against RTA, and expenses, including but not limited to reasonable attorney's fees; and expense incurred in defense of RTA, arising out of, or in any way incidental to, or in connection with the work hereunder, and other activities by contractor; provided, however, that such indemnification shall apply only to the extent permitted by applicable law, and except and to the extent such liability, claim, demand or cause of action results from RTA's negligence.

2.11 PERFORMANCE

Contractor shall perform all work diligently, carefully and in a good and workmanlike manner and shall furnish all labor, supervision, machinery, equipment, material and supplies necessary therefore. Contractor shall obtain and maintain all permits and licenses required by public authorities in connection with performance of the work, and, if permitted to subcontract, shall be fully responsible for all work performed by subcontractors. Contractor shall conduct all operations in Contractor's own name and as an independent contractor, and not in the name of, or agent for RTA.

2.12 STATUS OF CONTRACTOR AND ITS EMPLOYEES

For all purposes specified under the terms of this Agreement the Contractor shall be considered an independent contractor as defined in R.S. 23:1021 (5), and as such, the RTA shall not be liable to the Contractor for benefits or coverage provided by the Workers' Compensation Law of the State of Louisiana (R.S. 23:1021 et seq.), and further, under the provisions of R.S. 23:1034, no person employed by the Contractor shall be considered an employee of the RTA for the purpose of Workers' Compensation coverage.

2.13 INSURANCES

The contractor shall, upon request by the RTA, submit a copy of their standard insurance certificates for this project. During the term of this Agreement, the Contractor shall obtain and maintain the following types and amounts of insurance naming the Regional Transit Authority as an additional insured. The Contractor shall furnish to the RTA certificates showing types, amounts, class of operations covered, effective dates and dates of expiration of policies:

- A) Worker's Compensation Insurance as required by Louisiana Law;
- B) Vehicle Liability Insurance in the amount of \$1,000,000.00; and
- C) General Liability Insurance in the amount of \$1,000,000.

2.14 SUBCONTRACTORS

No portion of this contract may be, reassigned, transferred, or sublet without the written approval of the RTA. If allowed to subcontract, no subcontractor may be replaced without the written approval of the RTA.

2.15 ASSUMPTION OF RISK OF LOSS

Prior to acceptance, Contractor shall bear the risk of loss of the supplies, except that upon delivery, as defined in this Invitation for Bids, the RTA will bear the risk of loss due to the negligence of the RTA.

2.16 SHIPPING

The goods shall be delivered by the Contractor to the RTA's East New Orleans Facility 3900 Desire Pkwy, New Orleans LA, 70126. The RTA's Project Manager will coordinate the

delivery address with the Contractor prior to the shipment. The goods shall be delivered in excellent condition ready for utilization and/or installation. Contractor shall be responsible for unloading the goods at the specified location and assume all responsibility and liability incident to said delivery. All freight or shipping charges to bill as a separate line item.

2.17 DELIVERY

Delivery shall constitute the transfer of the supplies from the possession of the contractor to the possession of the RTA, as provided in this Invitation for Bids. Delivery shall be evidenced by a signed receipt issued by an authorized agent of the RTA. Items shall be delivered no later than 30 calendar days after the receipt of the executed contract and purchase order.

2.18 CERTIFICATE OF CONFORMANCE

The Contractor shall submit with each shipment a Certificate of Conformance signed by an authorized Contractor's Representative, stating that the materials furnished to Regional Transit Authority (RTA) are in conformance with applicable requirements of the Contract, drawings and specifications, and that supporting documentation is on file and will be made available to RTA or Federal Transit Representatives upon request. Certifications shall include name of Contractor for materials being supplied, quantity shipped, lot number, and Contract Number. An example of an acceptable statement of conformance is as follows:

“This is to certify that all items are noted in conformance with the Contract, drawings, specifications, and other applicable documentation.”

2.19 ACCEPTANCE

Within 7 days after delivery, the RTA, its agents or assigns will conduct acceptance inspection. Acceptance shall be conditioned upon satisfactory results of such inspection, promptly communicated in writing to the Contractor, subject however, to revocation upon discovery of defects.

2.20 QUALITY INSPECTION

All goods and services installed and supplied shall be good quality and free from any defects, and shall at all times be subject to RTA's inspection; but neither RTA's inspection nor failure to inspect shall relieve Contractor of any obligation hereunder. If, in RTA's opinion, any goods or service (or component thereof) fails to conform to specifications or is otherwise defective, Contractor shall promptly replace or correct same at Contractor's sole expense. No acceptance or payment by RTA shall constitute a waiver of the foregoing, and nothing herein shall exclude or limit any warranties implied by law.

2.21 CORRECTION BY CONTRACTOR

After non-acceptance of the work, the Contractor shall begin implementing correction procedures within five (5) calendar days after receiving notification from the RTA. The RTA will make the site timely with Contractor's correction schedule. The Contractor shall bear all

expense incurred to complete correction of the work after non-acceptance, and Contractor shall diligently implement correction procedures.

2.22 MATERIALS/ACCESSORIES RESPONSIBILITY

The Contractor shall provide and warranty all parts materials, equipment and workmanship associated with the supplies and related materials and equipment used, whether the same are manufactured by the Contractor or purchased from suppliers.

2.23 UNAVOIDABLE DELAYS

If completion of the work furnished under this contract should be unavoidably delayed, the RTA may extend the time for satisfaction of the Contractor's obligations pursuant thereto for a number of days determined by RTA to be excusable due to unavoidability. A delay is unavoidable only if the delay was not reasonably expected to occur in connection with or during the Contractor's performance, and was not caused directly or substantially by acts, omissions, negligence or mistakes of the Contractor, the Contractor's suppliers or their agents and was substantial and in fact caused the Contractor to miss completion dates and could not adequately have been guarded against by contractual or legal means.

2.24 NOTIFICATION OF DELAY

The Contractor shall notify the RTA as soon as the Contractor has, or should have, knowledge that an event has occurred or will occur which will delay progress or completion. Within five (5) days there from, the Contractor shall confirm such notice in writing furnishing as much detailed information as is available.

2.25 REQUESTS FOR EXTENSION

The Contractor agrees to supply, as soon as such data are available, any/all reasonable proof required by the RTA to make a decision relative to any request for extension. The RTA shall examine the request and any documents supplied by the Contractor, and RTA shall determine if the Contractor is entitled to an extension and the duration of such extension. The RTA shall notify the Contractor of this decision in writing. It is expressly understood and agreed that the Contractor shall not be entitled to damages or compensation, and shall not be reimbursed for losses on account of delays resulting from any cause under this provision.

2.26 ACCESS REQUIREMENTS FOR INDIVIDUALS WITH DISABILITIES

During the performance of this contract, the contractor, for itself, its assignees and successors in interest agree to comply with all applicable requirements of the Americans with Disabilities Act of 1990 (ADA), 42 U.S.C. sections 12101 et seq.; section 504 of the Rehabilitation Act of 1973, as amended, 29 U.S.C. section 794; section 16 of the Federal Transit Act, as amended, 49 U.S.C. app. section 1612; and the following regulations and any amendments thereto:

- (a) U.S. DOT regulations, "Transportation Services for Individuals with Disabilities (ADA)," 49 C.F.R. Part 37;
- (b) U.S. DOT regulations, "Nondiscrimination on the Basis of Handicap in Programs and Activities Receiving or Benefiting from Federal Financial Assistance," 49 C.F.R. Part 27;
- (c) U.S. DOT regulations, "American with Disabilities (ADA) Accessibility Specifications for Transportation Vehicles," 49 C.F.R. Part 38;
- (d) Department of Justice (DOJ) regulations, "Nondiscrimination on the Basis of Disability in State and Local Government Services," 28 C.F.R. Part 35;
- (e) DOJ regulations, "Nondiscrimination on the Basis of Disability by Public Accommodations and in Commercial Facilities," 28 C.F.R. Part 36;
- (f) General Services Administration regulations, "Accommodations for the Physically Handicapped," 41 C.F.R. Subpart 101-19;
- (g) Equal Employment Opportunity Commission, "Regulations to Implement the Equal Employment Provision of the Americans with Disabilities Act," 29 C.F.R. Part 1630;
- (h) Federal Communications Commission regulations, "Telecommunications Relay Services and Related Customer Premises Equipment for the Hearing and Speech Disabled," 47 C.F.R. Part 64, Subpart F; and
- (i) FTA regulations, "Transportation of Elderly and Handicapped Persons," 49 C.F.R. Part 609.

2.27 APPLICATION OF FEDERAL, STATE AND LOCAL LAWS AND REGULATIONS

(a) Federal Laws and Regulations

The Federal requirements (laws, regulations policies, and related administratively) contained in this contract may change (from time to time) after the date the contract has been executed. Any changes in federal requirements shall apply to this contract and be incorporated therein.

(b) State or Territorial Law and Local Law

This contract shall be entered into in the State of Louisiana and shall be governed and/or construed in accordance with the laws and jurisprudence of the State of Louisiana, except to the extent that a Federal Statute or regulation preempts State or territorial law.

2.28 CONTRACT PERIOD

THE TERM OF THIS CONTRACT SHALL BE SET FORTH IN THE CONTRACT AGREEMENT.

2.29 NO OBLIGATION BY THE FEDERAL GOVERNMENT

- (1) The Purchaser and Contractor acknowledge and agree that, notwithstanding any concurrence by the Federal Government in or approval of the solicitation or award of the underlying contract, absent the express written consent by the Federal Government, the Federal Government is not a party to this contract and shall not be subject to any obligations or liabilities to the Purchaser, Contractor, or any other party (whether or not a party to that contract) pertaining to any matter resulting from the underlying contract.
- (2) The Contractor agrees to include the above clause in each subcontract financed in whole or in part with Federal assistance provided by FTA. It is further agreed that the clause shall not be modified, except to identify the subcontractor who will be subject to its provisions.

2.30 FEDERAL CHANGES

Contractor shall at all times comply with all applicable FTA regulations, policies, procedures and directives, including without limitation those listed directly or by reference in the Agreement (Form FTA MA (2) dated October, 1995) between RTA and FTA, as they may be amended or promulgated from time to time during the term of this contract. Contractor's failure to so comply shall constitute a material breach of this contract.

2.31 INCORPORATION OF FEDERAL TRANSIT ADMINISTRATION (FTA) TERMS

The preceding provisions include, in part, certain Standard Terms and Conditions required by DOT, whether or not expressly set forth in the preceding contract provisions. All contractual provisions required by DOT, as set forth in FTA Circular 4220.1F, are hereby incorporated by reference. Anything to the contrary herein notwithstanding, all FTA mandated terms shall be deemed to control in the event of a conflict with other provisions contained in this Agreement. The Contractor shall not perform any act, fail to perform any act, or refuse to comply with any RTA requests which would cause RTA to be in violation of the FTA terms and conditions":<https://www.transit.dot.gov/regulations-and-guidance/fta-circulars/third-party-contracting-guidance>

2.32 EXCLUSIONARY OR DISCRIMINATORY SPECIFICATIONS

Apart from inconsistent requirements imposed by federal statute or regulations, the RTA will comply with the requirements of 49 U.S.C. § 5323(h) (2) by refraining from using any Federal assistance awarded by FTA to support procurements using exclusionary or discriminatory specifications.

2.33 GEOGRAPHIC RESTRICTIONS

Except as expressly mandated, encouraged or permitted by FTA or Federal statute, RTA will refrain from using state or local geographic preferences.

2.34 PROMPT PAYMENT

The prime contractor payment terms will be set forth in the contract agreement. Bills are to be paid within 30 days after receipt and acceptance of material and/or services - or - after receipt of a proper invoice whichever is later. The prime contractor agrees to pay each subcontractor under this prime contract for satisfactory performance of its contract no later than five (5) days from the receipt of each payment the prime contractor receives from the RTA. The prime contractor further agrees to return retainage payment to each subcontractor within five (5) days after the subcontractors' work is satisfactorily completed and accepted by RTA, and all lien delay's under applicable laws have expired. Any delay or postponement of payment from the above-referenced time frame may occur only for good cause following written approval of the RTA. This clause applies to both DBE and non-DBE subcontractors.

Identification of subcontractors: All prime contractors submitting offers in response to this Invitation for Bids must provide the following information for All subcontractors whether the firm is identified as a Disadvantaged Business Enterprise or not. The required information is:

- (1) Firm Name
- (2) Firm Address
- (3) Firm's status as a DBE or non DBE
- (4) The age of the firm
- (5) The annual gross receipts of the firm

Additionally, each contract RTA enters into with a contractor (and each subcontract) the prime contractor signs with a subcontractor shall include the following assurance:

The contractor, sub recipient or subcontractor shall not discriminate on the basis of race, color, national origin, or sex in the performance of this contract. The contractor shall carry out applicable requirements of 49 CFR Part 26 in the award and administration of DOT assisted contracts. Failure by the contractor to carry out these requirements is a material breach of this contract, which may result in the termination of this contract or such other remedy, as the RTA deems appropriate.

Further, each contract RTA enters into with a contractor (and each subcontract the prime contractor signs with a subcontractor shall include the following assurance:

The contractor, sub recipient or subcontractor shall make prompt payments for all satisfactory work performed under this agreement. The contractor shall within thirty (30) days of receipt of payment from RTA make all payments due subcontractors and suppliers. This requirement shall flow down to all levels including subcontractors making payments to sub subcontractors and suppliers, etc. Additionally, upon release of retainage(s) by RTA, Contractor shall in turn within thirty (30) days release retainage(s) it holds. The requirement for release of retainage(s) within thirty (30) days shall flow down to all subcontractors, etc. performing under this contract. Contractor or any of its subcontractors, etc. may not delay or postpone payments or release of retainage without prior RTA written approval. RTA may delay, or withhold up to twenty-five percent of

Contractor's payments, retainage, etc. if there is evidence that Contractor is not complying with any provision hereunder. RTA may withhold monies due Contractor until such time as Contractor by its actions or assurances has, to RTA satisfaction, proven that it will or has complied with all the requirements hereunder.

2.35 CONFIDENTIALITY

Contractor agrees that any and all information, in oral or written form, whether obtained from RTA, its agents or assigns, or other sources, or generated by Contractor pursuant to this contract shall not be used for any purpose other than fulfilling the requirements of this contract. Contractor further agrees to keep in absolute confidence all data relative to the business of RTA, their agents or assigns. No news release, including but not limited to photographs and film, public announcement, denial or confirmation of any part of the subject matter of any phase of any program hereunder shall be made by Contractor without written approval of RTA.

2.36 DISPUTES

Disputes arising in the performance of this Contract which are not resolved by agreement of the parties shall be decided in writing by the Director of Procurement. The decision of the Director of Procurement shall be final and conclusive unless within [seven (7)] days from the date of receipt of its copy, the Contractor mails or otherwise furnishes a written appeal to the CEO-RTA. In connection with any such appeal, the Contractor may be afforded an opportunity to be heard and to offer evidence in support of its position. The decision of the CEO-RTA shall be binding upon the Contractor and the Contractor shall abide by the decision.

Performance During Dispute. Unless otherwise directed by RTA, Contractor shall continue performance under this contract while matters in dispute are being resolved.

Claims for Damages. Should either party to the Contract suffer injury or damage to person or property because of any act or omission of the party or of any of his employees, agents or others for whose acts he is legally liable, a claim for damages therefore shall be made in writing to such other party within a reasonable time after the first observance of such injury or damage.

Remedies. Unless this contract provides otherwise, all claims, counterclaims, disputes and other matters in question between the RTA and the Contractor arising out of or relating to this agreement or its breach will be decided by arbitration if the parties mutually agree, or in a court of competent jurisdiction within the State of Louisiana.

Rights and Remedies. The duties and obligations imposed by the Contract Documents and the rights and remedies available thereunder shall be in addition to and not a limitation of any duties, obligations, rights and remedies otherwise imposed or available by law. No action or failure to act by the RTA, (its agents or assigns) or Contractor shall constitute a waiver of any right or duty afforded any of them under the Contract, nor shall any such action or failure to act constitute an approval of or acquiescence in any breach thereunder, except as may be specifically agreed in writing.

2.37 OWNERSHIP OF DOCUMENTS

Any documents, drawings, specifications, reports or data generated by the Contractor in connection with this project shall become the sole property of the RTA, subject to any rights asserted by FTA of the U.S. Department of Transportation. The Contractor may retain copies of such items for its files. The Contractor shall not release any documents, reports or data from this project without prior written permission from the RTA.

2.38 STATE AND LOCAL LAW DISCLAIMER

The use of many of the Clauses herein are not governed by federal law, many of the clauses contained herein contain FTA suggested language in certain instances these clauses may be affected by State Law.

2.39 PARTICIPANT INFORMATION FORM

All participants and their subcontractors are required to submit a completely executed, Participant Information Form available on <http://www.norta.com>.

2.40 NON-COLLUSION AFFIDAVIT

The Non-Collusion Affidavit is a required submittal. The necessary form is available on <http://www.norta.com>.

2.41 REGIONAL TRANSIT AUTHORITY GENERAL PROVISIONS

The Regional Transit Authority's General Provisions shall apply to this solicitation and resulting contract.

III. FEDERAL PROVISIONS AND REQUIREMENTS

3.1 ACCESS TO RECORDS

The following access to records requirements apply to this Contract:

- (1) RTA is a grantee of the FTA and as such in accordance with 49 C.F.R. 18.36(I), the Contractor agrees to provide the RTA, the FTA Administrator, the Comptroller General of the United States or any of their authorized representatives access to any books, documents, papers and records of the Contractor which are directly pertinent to this contract for the purposes of making audits, examinations, excerpts and transcriptions. Contractor also agrees, pursuant to 49 C.F.R. 633.17 to provide the FTA Administrator or his authorized representatives including any PMO Contractor access to Contractor's records and construction sites pertaining to a major capital project, defined at 49 U.S.C. 5302(a)1, which is receiving federal financial assistance through the programs described at 49 U.S.C. 5307, 5309 or 5311.
- (2) Where the Purchaser is a State and is the RTA or a subgrantee of RTA in accordance with 49 C.F.R. 633.17, Contractor agrees to provide the Purchaser, the

FTA Administrator or his authorized representatives, including PMP Contractor, access to Contractor's records and construction sites pertaining to a major capital project, defined at 49 U.S.C. 5302(a) 1, which is receiving federal financial assistance through the programs described at 49 U.S.C. 5307, 5309 or 5311. By definition, a major capital project excludes contracts of less than the simplified acquisition threshold currently set at \$100,000.

- (3) Where the RTA enters into a negotiated contract for other than a small purchase or under the simplified acquisition threshold and is an institution of higher education, an hospital or other non-profit organization and is the FTA grantee or a subgrantee of the RTA in accordance with 49 C.F.R. 19.48, Contractor agrees to provide the RTA, FTA Administrator, the Comptroller General of the United States or any of their duly authorized representatives with access to any books, documents, papers and record of the Contractor which are directly pertinent to this contract for the purposes of making audits, examinations, excerpts and transcriptions.
- (4) Where RTA or a subgrantee of the RTA in accordance with 49 U.S. C. 5325(a) enters into a contract for a capital project or improvement (defined at 49 U.S. C. 5302(a) 1) through other than competitive bidding, the Contractor shall make available records related to the contract to the RTA, the Secretary of Transportation and the Comptroller General or any authorized officer or employee of any of them for the purposes of conducting an audit and inspection.
- (5) The Contractor agrees to permit any of the foregoing parties to reproduce by any means whatsoever or to copy excerpts and transcriptions as reasonably needed.
- (6) The Contractor agrees to maintain all books, records, accounts and reports required under this contract for a period of not less than three (3) years after the date of termination or expiration of this contract, except in the event of litigation or settlement of claims arising from the performance of this contract, in which case Contractor agrees to maintain same until the RTA, the FTA Administrator, the Comptroller General, or any of their duly authorized representatives, have disposed of all such litigation, appeals, claims or exceptions thereto. Reference 49 CFR 18.39(i) (11).

3.2 BUY AMERICA

This Contract is subject to the Federal Transit Administration Buy America Requirements in 49 CFR 660. The bidder is required to submit a signed Buy America certification with the bid. If the bidder takes exception to the Buy America requirements a certificate of non-compliance must be signed and submitted with the bid as it applies to the IFB request. The necessary forms are available on <http://www.norta.com>. A waiver from the Buy America Provision may be sought by the RTA if grounds for the waiver exist. Section 165(a) of the Surface Transportation Act of 1982 permits FTA participation on this contract only if steel, and manufactured products used in the contract are produced in the United States.

3.3 PRE-AWARD AND POST-DELIVERY AUDITS

Federal funds may not be obligated unless steel, iron, and manufactured products used in the projects are produced in the United States, unless FTA has granted a waiver, or the product is

subject to a general waiver. 49 U.S.C. Section (5323(j)/FAST Section 3011 domestic content percentage requirement for rolling stock for fiscal years 2018-2019 must have sixty-five percent domestic content and final assembly must take place in the United States. The Buy America Requirements, CFR Part 661.11(r), define final assembly as “the creation of the end product from individual elements brought together for that purpose through application of manufacturing processes.”

3.4 CARGO PREFERENCE

The Contractor Agrees:

- a. To utilize privately owned United States-flag commercial vessels to ship at least 50 percent of the gross tonnage (computed separately for dry bulk carriers, dry cargo liners and tankers) involved, whenever shipping any equipment, materials, or commodities pursuant to this contract, to the extent such vessels are available at fair and reasonable rates for United States-flag commercial vessels;
- b. To furnish within 20 working days following the date of loading for shipments originating within the United States or within 30 working days following the date of loading for shipments originating outside the United States, a legible copy of a rated, "on-board" commercial ocean bill-of-lading in English for each shipment of cargo described in the preceding paragraph to the Division of National Cargo, Office of Market Development, Maritime Administration, Washington, D.C. 20590 and to the RTA (through the prime contractor in the case of subcontractor's bills-of-lading).
- c. To include these requirements in all subcontracts issued pursuant to this contract when the contract may involve the transportation of equipment, material or commodities by ocean vessel.

3.5 CLEAN AIR ACT AND FEDERAL WATER POLLUTION CONTROL ACT

- (1) The Contractor agrees to comply with all applicable standards, orders or regulations issued pursuant to the Clean Air Act, as amended, 42 U.S.C. §§ 7401 et seq. The Contractor agrees to report each violation to the RTA and understands and agrees that the RTA will, in turn, report each violation as required to assure notification to FTA and the appropriate EPA Regional Office.
- (2) The Contractor also agrees to include these requirements in each subcontract exceeding \$100,000 financed in whole or in part with Federal assistance provided by FTA.
- (3) The Contractor agrees to comply with applicable standards, orders or regulations issued pursuant to the Federal Water Pollution Control Act, as amended, 33 U.S.C. 1251 et seq. The Contractor agrees to report each violation to the RTA and understands and agrees that the RTA will, in turn, report each violation as required to assure notification to FTA and the appropriate EPA Regional Office.

- (4) The Contractor also agrees to include these requirements in each subcontract exceeding \$100,000 financed in whole or in part with Federal assistance provided by FTA.
- (5) **14 CFR § 1274.926 Clean Air-Water Pollution Control Acts.**
If this contract or supplement thereto is in excess of \$100,000, the Recipient agrees to notify the Agreement Officer promptly of the receipt, whether prior or subsequent to the Recipient's acceptance of this agreement, of any communication from the Director, Office of Federal Activities, Environmental Protection Agency (EPA), indicating that a facility to be utilized under or in the performance of this agreement or any subcontract thereunder is under consideration to be listed on the EPA "List of Violating Facilities" published pursuant to 40 CFR 15.20. By acceptance of agreement in excess of \$100,000, the Recipient
- (a) Stipulates that any facility to be utilized thereunder is not listed on the EPA "List of Violating Facilities" as of the date of acceptance;
- (b) Agrees to comply with all requirements of section 114 of the Clean Air Act, as amended (42 U.S.C. 1857et seq. as amended by Public Law 91-604) and section 308 of the Federal Water Pollution Control Act, as amended (33 U.S.C. 1251et seq. as amended by Public Law 92-500) relating to inspection, monitoring, entry, reports and information, and all other requirements specified in the aforementioned sections, as well as all regulations and guidelines issued thereunder after award of and applicable to the contract; and
- (c) Agrees to include the criteria and requirements of this clause in every subcontract hereunder in excess of \$100,000, and to take such action as the Contracting or Grant Officer may direct to enforce such criteria and requirements.

3.6 CIVIL RIGHTS ACT

The following requirements apply to the underlying contract:

(1) Nondiscrimination. In accordance with Title VI of the Civil Rights Act, as amended, 42 U.S.C. § 2000d, section 303 of the Age Discrimination Act of 1975, as amended, 42 U.S.C. § 6102, section 202 of the Americans with Disabilities Act of 1990, 42 U.S.C. § 12132, and Federal transit law at 49 U.S.C. § 5332, the Contractor agrees that it will not discriminate against any employee or applicant for employment because of race, color, creed, national origin, sex, age, or disability. In addition, the Contractor agrees to comply with applicable Federal implementing regulations and other implementing requirements FTA may issue.

(2) Equal Employment Opportunity: The following equal employment opportunity requirements apply to the underlying contract:

(a) Race, Color, Creed, National Origin, Sex. In accordance with Title VII of the Civil Rights Act, as amended, 42 U.S.C. § 2000e, and Federal transit laws at 49 U.S.C. § 5332, the Contractor agrees to comply with all applicable equal employment opportunity requirements of U. S. Department of Labor (U.S. DOL) regulations, "Office of Federal Contract Compliance Programs, Equal Employment Opportunity, Department of Labor," 41 C.F.R. Parts 60 et seq., (which implement Executive Order No. 11246, "Equal

Employment Opportunity,” as amended by Executive Order No. 11375, “Amending Executive Order 11246 Relating to Equal Employment Opportunity,” 42 U.S. C. § 2000e note), and with any applicable Federal statutes, executive orders, regulations, and Federal policies that may in the future affect construction activities undertaken in the course of the Project. The Contractor agrees to take affirmative action to ensure that applicants are employed, and that employees are treated during employment, without regard to their race, color, creed, national origin, sex, disability or age. Such action shall include, but not be limited to, the following: employment, upgrading, demotion or transfer, recruitment or recruitment advertising, layoff or termination; rates of pay or other forms of compensation; and selection for training, including apprenticeship. In addition, the Contractor agrees to comply with any implementing requirements FTA may issue.

(b) Age. In accordance with section 4 of the Age Discrimination in Employment Act of 1967, as amended, 29 U.S.C. §§ 623 and Federal transit law at 49 U.S.C. § 5332, the Contractor agrees to refrain from discrimination against present and prospective employees for reason of age. In addition, the Contractor agrees to comply with any implementing requirements FTA may issue.

(c) Disabilities. In accordance with section 102 of the Americans with Disabilities Act, as amended, 42 U.S. C. § 12112, the Contractor agrees that it will comply with the requirements of U. S. Equal Employment Opportunity Commission, “Regulations to Implement the Equal Employment Provisions of the Americans with Disabilities Act”, 29 C.F.R. Part 1630, pertaining to employment of persons with disabilities. In addition, the Contractor agrees to comply with any implementing requirements FTA may issue.

(3) The Contractor also agrees to include these requirements in each Subcontract financed in whole or in part with Federal assistance provided by FTA, modified only if necessary to identify the affected parties.

3.7 DISADVANTAGED BUSINESS ENTERPRISE

It is the policy of the RTA to ensure that DBE’s as defined in Part 26, have an equal opportunity to participate to receive and participate in DOT-assisted contracts. It is, also, our policy –

- (i) To ensure nondiscrimination in the award and administration of DOT assisted contracts;
- (ii) To create level playing field in which DBE’s can compete fairly for DOT assisted contracts;
- (iii) To ensure that the DBE Program is narrowly tailored in accordance with applicable law;
- (iv) To ensure that only firms that fully meet 49 CFR Part 26 eligibility standards are permitted to participate as DBE’s;
- (v) To help remove barriers to the participation of DBE's in DOT assisted contracts;

- (vi) To assist the development of firms that can compete successfully in the market place outside the DBE program.

CONTRACTOR ASSURANCE. The contractor, sub recipient, or subcontractor shall not discriminate on the basis of race, color, national origin, or sex in the performance of this contract. The contractor shall carry out applicable requirements of 49 CFR Part 26 in the award and administration of DOT assisted contracts. Failure by the contractor to carry out these requirements is a material breach of this contract, which may result in the termination of this contract or such other remedy, as the recipient deems appropriate.

The **NORTA Small and Disadvantaged Business Enterprise Contract Compliance System** is powered by **B2Gnow** Software

Reporting requirements under the SBE and DBE programs are now simplified for vendors working on RTA projects with RTA's new Small and Disadvantaged Business Enterprise Contract Compliance System. Our new web-based software system is accessible to government compliance administrators, SBE's, DBE's, contractors and the public; and includes the following key features:

- Self-managed vendor accounts with unlimited users
- Communication with contractors via email, regarding compliance issues
- Online submission of contractor and supplier monthly Program Activity Reports, with automated tracking of DBE and SBE goals
- DBE and SBE firm online verification of payments
- Flexible reporting capabilities

*All RTA contract awarded vendors are required to register contract information including their subcontractor information into the B2GNOW database.

<https://norta.dbesystem.com>

3.8 EMPLOYEE PROTECTION

Construction Activities. The Recipient agrees to comply, and assures the compliance of each sub recipient, lessee, third party contractor, and other participant at any tier of the Project, with the following Federal laws and regulations providing protections for construction employees: (1) Davis-Bacon Act, as amended, 40 U.S.C. §§ 3141 et seq., pursuant to FTA enabling legislation requiring compliance with the Davis-Bacon Act at 49 U.S.C. § 5333(a), and implementing U.S. DOL regulations, "Labor Standards Provisions Applicable to Contracts Governing Federally Financed and Assisted Construction (also Labor Standards Provisions Applicable to Nonconstruction Contracts Subject to the Contract Work Hours and Safety Standards Act)," 29 C.F.R. Part 5; (2) Contract Work Hours and Safety Standards Act, as amended, 40 U.S.C. §§ 3701 et seq., specifically, the wage and hour requirements of section 102 of that Act at 40 U.S.C. § 3702, and implementing U.S. DOL regulations, "Labor Standards Provisions Applicable to Contracts Governing Federally Financed and Assisted Construction (also Labor Standards Provisions Applicable to Nonconstruction Contracts Subject to the Contract Work Hours and Safety Standards Act)," 29 C.F.R. Part 5; and the safety requirements of section 107 of that Act at 40 U.S.C. § 3704, and implementing U.S. DOL regulations, "Safety and Health Regulations for Construction," 29 C.F.R. Part 1926; and (3) Copeland "Anti-Kickback" Act, as amended, 18 U.S.C. § 874 and 40 U.S.C. § 3145, and implementing U.S. DOL regulations, "Contractors and Subcontractors on Public Building or Public Work Financed in Whole or in part by Loans or Grants from the United States," 29 C.F.R. Part 3. b. Activities Not Involving Construction. The Recipient agrees to comply, and assures the compliance of each subrecipient, lessee, third party contractor, and other participant at any tier of the Project, with the employee protection requirements for nonconstruction employees of the Contract Work Hours and Safety Standards

Act, as amended, 40 U.S.C. §§ 3701 et seq., in FTA Master Agreement MA(17), 10-1-2010 58 particular with the wage and hour requirements of section 102 of that Act at 40 U.S.C. § 3702, and with implementing U.S. DOL regulations, “Labor Standards Provisions Applicable to Contracts Governing Federally Financed and Assisted Construction (also Labor Standards Provisions Applicable to Nonconstruction Contracts Subject to the Contract Work Hours and Safety Standards Act),” 29 C.F.R. Part 5. c. Activities Involving Commerce. The Recipient agrees to comply with the Fair Labor Standards Act, 29 U.S.C. §§ 201 et seq., to the extent that it applies to employees performing Project work involving commerce. d. Public Transportation Employee Protective Arrangements. If the Contract Agreement for the Project indicates that public transportation employee protective arrangements required by U.S. DOL apply to public transportation operations performed in connection with the Project, the Recipient agrees to comply with the following requirements:

(1) Standard Public Transportation Employee Protective Arrangements. To the extent that the Project involves public transportation operations and to the extent required by Federal law, the Recipient agrees to implement the Project in accordance with the terms and conditions that the U.S. Secretary of Labor has determined to be fair and equitable to protect the interests of any employees affected by the Project and that comply with the requirements of 49 U.S.C. § 5333(b), in accordance with U.S. DOL guidelines, “Section 5333(b), Federal Transit Law,” 29 C.F.R. Part 215, and any amendments thereto.

3.9 ENERGY CONSERVATION

The Contractor agrees to comply with mandatory standards and policies relating to energy efficiency which are contained in the state energy conservation plan issued in compliance with the Energy Policy and Conservation Act (42 U.S.C. 6321 et seq.).

3.10 FLY AMERICA

Contractor and all subcontractors at every tier shall comply with the requirements of 49 U.S.C. 40118 and 4 CFR Part 52. Specifically, whenever work under this agreement may involve international transportation of goods, equipment or personnel by air, only U.S. flag air carriers shall be utilized, to the extent service by these carriers is available. Additionally, Contractor and any subcontractors at every tier shall include this requirement in all subcontracts. Further, in every instance where Contractor or any subcontractor(s) cannot comply with the requirements herein, a certification, in proper form, stating the reasons for non-compliance shall accompany the request for reimbursement or payment.

3.11 GOVERNMENT WIDE DEBARMENT AND SUSPENSION (NONPROCUREMENT)

Certification Regarding Debarment, Suspension, and other Responsibility Matters -
Lower Tier Covered Transactions (Third Party Contracts over \$100,000)

The following language and Debarment certificates (<http://www.norta.com>) must be completed and submitted as a prerequisite for consideration for award. This language and certification must also be included for all sub-contracts issued pursuant to any contract awarded hereunder.

Instructions for Certification

1. By signing and submitting this bid or proposal, the prospective lower tier participant is providing the signed certification set out below.
2. The certification in this clause is a material representation of fact upon which reliance was placed when this transaction was entered into. If it is later determined that the prospective lower tier participant knowingly rendered an erroneous certification, in addition to other remedies available to the Federal Government, RTA may pursue available remedies, including suspension and/or debarment.
3. The prospective lower tier participant shall provide immediate written notice to RTA if at any time the prospective lower tier participant learns that its certification was erroneous when submitted or has become erroneous by reason of changed circumstances.
4. The terms “covered transaction”, “debarred”, “suspended”, “ineligible”, “lower tier covered transaction”, “participant”, “persons”, “lower tier covered transaction”, “principal”, “proposal”, and “voluntarily excluded”, as used in this clause, have meanings set out in the Definitions and Coverage sections of rules implementing Executive Order 12549 [49 CFR Part 29].
5. The prospective lower tier participant agrees by submitting this proposal that, should the proposed covered transaction be entered into, it shall not knowingly enter into any lower tier covered transaction with a person who is debarred, suspended, declared ineligible, or voluntarily excluded from participation in this covered transaction, unless authorized in writing by RTA.
6. The prospective lower tier participant further agrees by submitting this proposal that it will include the clause titled “Certification Regarding Debarment, Suspension, Ineligibility and Voluntary Exclusion - Lower Tier Covered Transaction”, without modification, in all lower tier covered transactions and in all solicitation for lower tier covered transaction.
7. A participant in a covered transaction may rely upon a certification of a prospective participant in a lower tier covered transaction that it is not debarred, suspended, ineligible, or voluntarily excluded from the covered transaction, unless it knows that the certification is erroneous. A participant may decide the method and frequency by which it determines the eligibility of its principals. Each participant may, but is not required to, check the Non-Procurement List issued by U.S. General Service Administration.
8. Nothing contained in the foregoing shall be construed to require establishment of a system of records in order to render in good faith the certification required by this clause. The knowledge and information of a participant is not required to exceed that which is normally possessed by a prudent person in the ordinary course of business dealings.
9. Except for transactions authorized under Paragraph 5 of these instructions, if a participant in a covered transaction knowingly enters into a lower tier covered transaction with a person who is suspended, debarred, ineligible, or voluntarily excluded from participation

in this transaction, in addition to all remedies available to the Federal Government, RTA may pursue available remedies including suspension and/or Debarment.

3.12 RESTRICTIONS ON LOBBYING

Byrd Anti-Lobbying Amendment, 31 U.S.C. 1352, as amended by the Lobbying Disclosure Act of 1995, P.L. 104-65 [to be codified at 2 U.S.C. § 1601, et seq.] Contractors who apply or bid for an award of \$100,000 or more shall file the certification required by 49 CFR parts 20, "New Restrictions on Lobbying." Each tier certifies to the tier above that it will not and has not used Federal appropriated funds to pay any person or organization for influencing or attempting to influence an officer or employee of any agency, a member of Congress, officer or employee of Congress, or an employee of a member of Congress in connection with obtaining any Federal contract, grant or any other award covered by 31 U.S.C. 1352. Each tier shall also disclose the name of any registrant under the Lobbying Disclosure Act of 1995 who has made lobbying contacts on its behalf with non-Federal funds with respect to that Federal contract, grant or award covered by 31 U.S.C. 1352. Such disclosures are forwarded from tier to tier up to the RTA. The necessary form is available on <http://www.norta.com>.

3.13 NO FEDERAL GOVERNMENT OBLIGATIONS TO THIRD PARTIES

The federal government shall not be subject to any obligations or liabilities to any third-party Contractor, or any other person not a party to the Grant Agreement or Cooperative Agreement in connection with the performance of this contract. Notwithstanding any concurrence provided by the federal government in or approval of any solicitation, subagreement, or third-party contract, the federal government continues to have no obligations or liabilities to any party, including the third-party Contractor.

3.14 PATENT AND RIGHTS IN DATA

These following requirements apply to each contract involving experimental, developmental or research work: 1. The term "subject data" used in this clause means recorded information, whether or not copyrighted, that is delivered or specified to be delivered under the contract. The term includes graphic or pictorial delineation in media such as drawings or photographs; text in specifications or related performance or design-type documents; machine forms such as punched cards, magnetic tape, or computer memory printouts; and information retained in computer memory. Examples include, but are not limited to: computer software, engineering drawings and associated lists, specifications, standards, process sheets, manuals, technical reports, catalog item identifications, and related information. The term "subject data" does not include financial reports, cost analyses, and similar information incidental to contract administration. 2. The following restrictions apply to all subject data first produced in the performance of the contract to which this Attachment has been added: a. Except for its own internal use, the Contractor may not publish or reproduce subject data in whole or in part, or in any manner or form, nor may the Contractor authorize others to do so, without the written consent of the Federal Government, until such time as the Federal Government may have either released or approved the release of such data to the public; this restriction on publication, however, does not apply to any contract with an academic institution. b. In accordance with 49 C.F.R. § 18.34 and 49 C.F.R. § 19.36, the Federal Government reserves a royalty-free, non-exclusive and irrevocable license to reproduce, publish, or otherwise use, and to authorize others to use, for "Federal Government purposes," any

subject data or copyright described in subsections (2)(b)1 and (2)(b)2 of this clause below. As used in the previous sentence, "for Federal Government purposes," means use only for the direct purposes of the Federal Government. Without the copyright owner's consent, the Federal Government may not extend its Federal license to any other party. (1). Any subject data developed under that contract, whether or not a copyright has been obtained; and (2). Any rights of copyright purchased by the Contractor using Federal assistance in whole or in part provided by FTA. c. When FTA awards Federal assistance for experimental, developmental, or research work, it is FTA's general intention to increase transportation knowledge available to the public, rather than to restrict the benefits resulting from the work to participants in that work. Therefore, unless FTA determines otherwise, the Contractor performing experimental, developmental, or research work required by the underlying contract to which this Attachment is added agrees to permit FTA to make available to the public, either FTA's license in the copyright to any subject data developed in the course of that contract, or a copy of the subject data first produced under the contract for which a copyright has not been obtained. If the experimental, developmental, or research work, which is the subject of the underlying contract, is not completed for any reason whatsoever, all data developed under that contract shall become subject data as defined in subsection (a) of this clause and shall be delivered as the Federal Government may direct. This subsection (c), however, does not apply to adaptations of automatic data processing equipment or programs for the Contractor's use whose costs are financed in whole or in part with Federal assistance provided by FTA for transportation capital projects. d. Unless prohibited by state law, upon request by the Federal Government, the Contractor agree to indemnify, save, and hold harmless the Federal Government, its officers, agents, and employees acting within the scope of their official duties against any liability, including costs and expenses, resulting from any willful or intentional violation by the Contractor of proprietary rights, copyrights, or right of privacy, arising out of the publication, translation, reproduction, delivery, use, or disposition of any data furnished under that contract. Contractor shall not be required to indemnify the Federal Government for any such liability arising out of the wrongful act of any employee, official, or agents of the Federal Government. e. Nothing contained in this clause on rights in data shall imply a license to the Federal Government under any patent or be construed as affecting the scope of any license or other right otherwise granted to the Federal Government under any patent. f. Data developed by Contractor and financed entirely without using Federal assistance provided by the Federal Government that has been incorporated into work required by the underlying contract to which this Attachment has been added is exempt from the requirements of subsections (b), (c), and (d) of this clause, provided that the Contractor identifies that data in writing at the time of delivery of the contract work. g. Unless FTA determines otherwise, the Contractor agrees to include these requirements in each subcontract for experimental, developmental, or research work financed in whole or in part with Federal assistance provided by FTA. 3. Unless the Federal Government later makes a contrary determination in writing, irrespective of the Contractor's status (i.e., a large business, small business, state government or state instrumentality, local government, nonprofit organization, institution of higher education, individual, etc.), Contractor agrees to take the necessary actions to provide, through FTA, those rights in that invention due the Federal Government as described in U.S. Department of Commerce regulations, "Rights to Inventions Made by Nonprofit Organizations and Small Business Firms Under Government Grants, Contracts and Cooperative Agreements," 37 C.F.R. Part 401. 4. The Contractor also agrees to include these requirements in each subcontract for experimental, developmental, or research work financed in whole or in part with Federal assistance provided by FTA.

3.15 PROGRAM FRAUD AND FALSE OR FRAUDULENT STATEMENTS AND RELATED ACTS UPPER AND LOWER TIER TRANSACTIONS

- (1) The Contractor acknowledges that the provisions of the Program Fraud Civil Remedies Act of 1986, as amended, 31 U.S.C. §§3801 et. seq. and U.S. DOT regulations, “Program Fraud Civil Remedies”, 49 C.F.R. Part 31, apply to its actions pertaining to this Project. Upon execution of the underlying contract, the Contractor certifies or affirms the truthfulness and accuracy of any statement it has made, it makes, it may make, or causes to be made, pertaining to the underlying contract or the FTA assisted project for which this contract work is being performed. In addition to other penalties that may be applicable, the Contractor further acknowledges that if it makes, or causes to be made, a false, fictitious, or fraudulent claim, statement, submission, or certification, the Federal Government reserves the right to impose the penalties of the Program Fraud Civil Remedies Act of 1986 on the Contractor to the extent the Federal Government deems appropriate.
- (2) The Contractor also acknowledges that if it makes, or causes to be made, a false, fictitious, or fraudulent claim, statement, submission, or certification to the Federal Government under a contract connected with a project that is financed in whole or in part with Federal assistance originally awarded by FTA under the authority of 49 U.S. C. §5307, the Government reserves the right to impose the penalties of 18 U.S.C. §1001 and 49 U.S.C. §5307(n)(1) on the Contractor, to the extent the Federal Government deems appropriate.
- (3) The Contractor agrees to include the above two clauses in each subcontract financed in whole or in part with Federal assistance provided by FTA. It is further agreed that the clauses shall not be modified, except to identify the subcontractor who will be subject to the provisions.

3.16 RECYCLED PRODUCTS

Recovered Materials. The contractor agrees to comply with all the requirements of Section 6002 of the Resource Conservation and Recovery Act (RCRA), as amended (42 U.S.C. 6962), including but not limited to the regulatory provisions of 40 CFR Part 247, and Executive Order 12873, as they apply to the procurement of the items designated in Subpart B of 40 CFR Part 247.

3.17 SUBSTANCE ABUSE REQUIREMENTS

To the extent applicable, the Recipient agrees to comply with the following Federal regulations and guidance: a. Drug-Free Workplace. U.S. OMB guidance, “Governmentwide Requirements for Drug-Free Workplace (Financial Assistance),” 2 C.F.R. Part 182, and U.S. DOT regulations, “Governmentwide Requirements for Drug-Free Workplace (Financial Assistance),” 49 C.F.R. Part 32, that implement the Drug-Free Workplace Act of 1988, as amended, 41 U.S.C. §§ 702 et seq., including any amendments to these U.S. DOT regulations when they are promulgated. b. Alcohol Misuse and Prohibited Drug Use. FTA regulations, “Prevention of Alcohol Misuse and Prohibited Drug Use in Transit Operations,” 49 C.F.R. Part 655, that implement 49 U.S.C. § 5331.

3.18 TERMINATION

a. Termination for Convenience (General Provision) The RTA may terminate this contract, in whole or in part, at any time by written notice to the Contractor when it is in the

RTA's and/or the Government's best interest. The Contractor shall be paid its costs, including contract closeout costs, and profit on work performed up to the time of termination. The Contractor shall promptly submit its termination claim to RTA to be paid the Contractor. If the Contractor has any property in its possession belonging to the RTA, the Contractor will account for the same, and dispose of it in the manner the RTA directs.

b. Termination for Default [Breach or Cause] (General Provision) If the Contractor does not deliver supplies in accordance with the contract delivery schedule, or, if the contract is for services, the Contractor fails to perform in the manner called for in the contract, or if the Contractor fails to comply with any other provisions of the contract, the RTA may terminate this contract for default. Termination shall be affected by serving a notice of termination on the contractor setting forth the manner in which the Contractor is in default. The contractor will only be paid the contract price for supplies delivered and accepted, or services performed in accordance with the manner of performance set forth in the contract. If it is later determined by the RTA that the Contractor had an excusable reason for not performing, such as a strike, fire, or flood, events which are not the fault of or are beyond the control of the Contractor, the RTA, after setting up a new delivery or performance schedule, may allow the Contractor to continue work, or treat the termination as a termination for convenience.

c. Opportunity to Cure (General Provision) The RTA in its sole discretion may, in the case of a termination for breach or default, allow the Contractor [an appropriately short period of time] in which to cure the defect. In such case, the notice of termination will state the time period in which cure is permitted and other appropriate conditions. If Contractor fails to remedy to RTA's satisfaction the breach or default or any of the terms, covenants, or conditions of this Contract within [ten (10) days] after receipt by Contractor of written notice from RTA setting forth the nature of said breach or default, (RTA) shall have the right to terminate the Contract without any further obligation to Contractor. Any such termination for default shall not in any way operate to preclude (RTA) from also pursuing all available remedies against Contractor and its sureties for said breach or default.

d. Waiver of Remedies for any Breach. In the event that RTA elects to waive its remedies for any breach by Contractor of any covenant, term or condition of this Contract, such waiver by RTA shall not limit RTA's remedies for any succeeding breach of that or of any other term, covenant, or condition of this Contract.

ATTACHMENT I
TECHNICAL SPECIFICATIONS

ATTACHMENT II

LOUISIANA UNIFORM PUBLIC WORK BID FORM

TO: Regional Transit Authority
ATTN: Procurement Department
2817 Canal Blvd.
New Orleans, LA 70119
(Owner to provide name and address of owner)

BID FOR: Streetcar Wheel Change
IFB No. 2024-040
(Owner to provide name of project and other identifying information)

The undersigned bidder hereby declares and represents that she/he; a) has carefully examined and understands the Bidding Documents, b) has not received, relied on, or based his bid on any verbal instructions contrary to the Bidding Documents or any addenda, c) has personally inspected and is familiar with the project site, and hereby proposes to provide all labor, materials, tools, appliances and facilities as required to perform, in a workmanlike manner, all work and services for the construction and completion of the referenced project, all in strict accordance with the Bidding Documents prepared by: Regional Transit Authority and dated: December 12, 2024.
(Owner to provide name of entity preparing bidding documents.)

Bidders must acknowledge all addenda. The Bidder acknowledges receipt of the following ADDENDA:

No. ___ Dated: ___ No. ___ Dated: ___ No. ___ Dated: ___

TOTAL BASE BID: For all work required by the Bidding Documents (including any and all unit prices designated "Base Bid" * but not alternates) the sum of:

Two-million, one-hundred forty-six thousand, seventy-three dollars and seventy-three cents Dollars (\$ 2,146,073.60)

ALTERNATES: For any and all work required by the Bidding Documents for Alternates including any and all unit prices designated as alternates in the unit price description.

Alternate No. 1 (Owner to provide description of alternate and state whether add or deduct) for the lump sum of: Dollars (\$ ___)

Alternate No. 2 (Owner to provide description of alternate and state whether add or deduct) for the lump sum of: Dollars (\$ ___)

Alternate No. 3 (Owner to provide description of alternate and state whether add or deduct) for the lump sum of: Dollars (\$ ___)

NAME OF BIDDER: Brookville Equipment Corporation

ADDRESS OF BIDDER: 175 Evans St. Brookville, Pa 15825

LOUISIANA CONTRACTOR'S LICENSE NUMBER OR TAX IDENTIFICATION NUMBER: 25-1259897

NAME OF AUTHORIZED SIGNATORY OF BIDDER: Dan Eberts

TITLE OF AUTHORIZED SIGNATORY OF BIDDER: Parts Sales Account Manager

SIGNATURE OF AUTHORIZED SIGNATORY OF BIDDER **: [Handwritten Signature]

DATE: 1/14/25

* The Unit Price Form shall be used if the contract includes unit prices. Otherwise, it is not required and need not be included with the form. The number of unit prices that may be included is not limited and additional sheets may be included if needed.

** If someone other than a corporate officer signs for the Bidder/Contractor, a copy of a corporate resolution or other signature authorization shall be required for submission of bid. Failure to include a copy of the appropriate signature authorization, if required, may result in the rejection of the bid unless bidder has complied with La. R.S. 38:2212(A) (1) (c) or RS 38:2212(O).

LOUISIANA UNIFORM PUBLIC WORK BID FORM
UNIT PRICE FORM

TO: Regional Transit Authority
 Attn: Procurement Department
 2817 Canal Blvd.
 New Orleans, LA 70119

BID FOR: IFB 2024-020
 Streetcar Wheel Change

UNIT PRICES: This form shall be used for any and all work required by the Bidding Documents and described as unit prices. Amounts shall be stated in figures and only in figures.

Please quote all individual pricing on the price sheet provided on the technical specifications sheet and quote total price on Louisiana Bid Form.

DESCRIPTION:	<input checked="" type="checkbox"/> Base Bid or <input type="checkbox"/> Alt.# ____			
LINE 1	QUAN TITY:	UNIT OF MEASURE:	UNIT PRICE	UNIT PRICE EXTENSION (<i>Quantity times Unit Price</i>)
28 " Wheel	128	EA	\$16,766.20	\$2,146,073.60

TECHNICAL SPECIFICATIONS

STREETCAR 28" STEEL TIRES

SCOPE:

The scope of this solicitation covers:

- a) 128 - 28" steel tires for Canal & Riverfront Streetcars.

SPECIFICATIONS:

- a) 28" Steel Tires, OEM Part No. 00707667
AAR M-107-LR Class "C" Wheels made to PM Drawing 707667
Wheels shall carry standard markings as per AAR M-107
Heat treated to 321–363 BHN per AAR M-107
Rim toughened and machined for service

DELIVERY:

Time 7 – 1:00 pm, Central Time, Weekdays, no holidays
Deliver to: Floyd Bailey
 8225 Willow Street
 New Orleans, LA 70118-2817
 504-827-8460

Shipping: 4 wheels per pallet, 32" X 32" pallets, strapped down
 Wrap each pallet with heavy-duty plastic cover
 Ship on open top flat bed trailers or trucks

TECHNICAL SPECIFICATIONS
RESILIENT DISC AND HARDWARE

SCOPE:

The scope of this solicitation covers:

- a) 2,048 Resilient Disc, Part Number 00577340
- b) 1,024 Hub Bolt, Part Number 00704442, M22-1.5 X 40MM Steel Grade 8.8
- c) 1,024 Nylon Insert Locknut, Part Number 00606316, M22-1.5 Steel Grade 10
- d) 1,024 Internal Tooth Star Lock Washer, Part Number 00577537, M22 Steel Grade 10

SPECIFICATIONS:

Hardware shall be plain finish and carry steel grade and thread pitch markings on head.

DELIVERY:

Time 7 – 1:00 pm, Central Time, Weekdays, no holidays
Deliver to: Floyd Bailey
 8225 Willow Street
 New Orleans, LA 70118-2817
 504-827-8460

SHIPPING:

Each hardware type shall be boxed 100 to the count.
Boxes placed on pallets and wrapped with heavy-duty plastic cover.

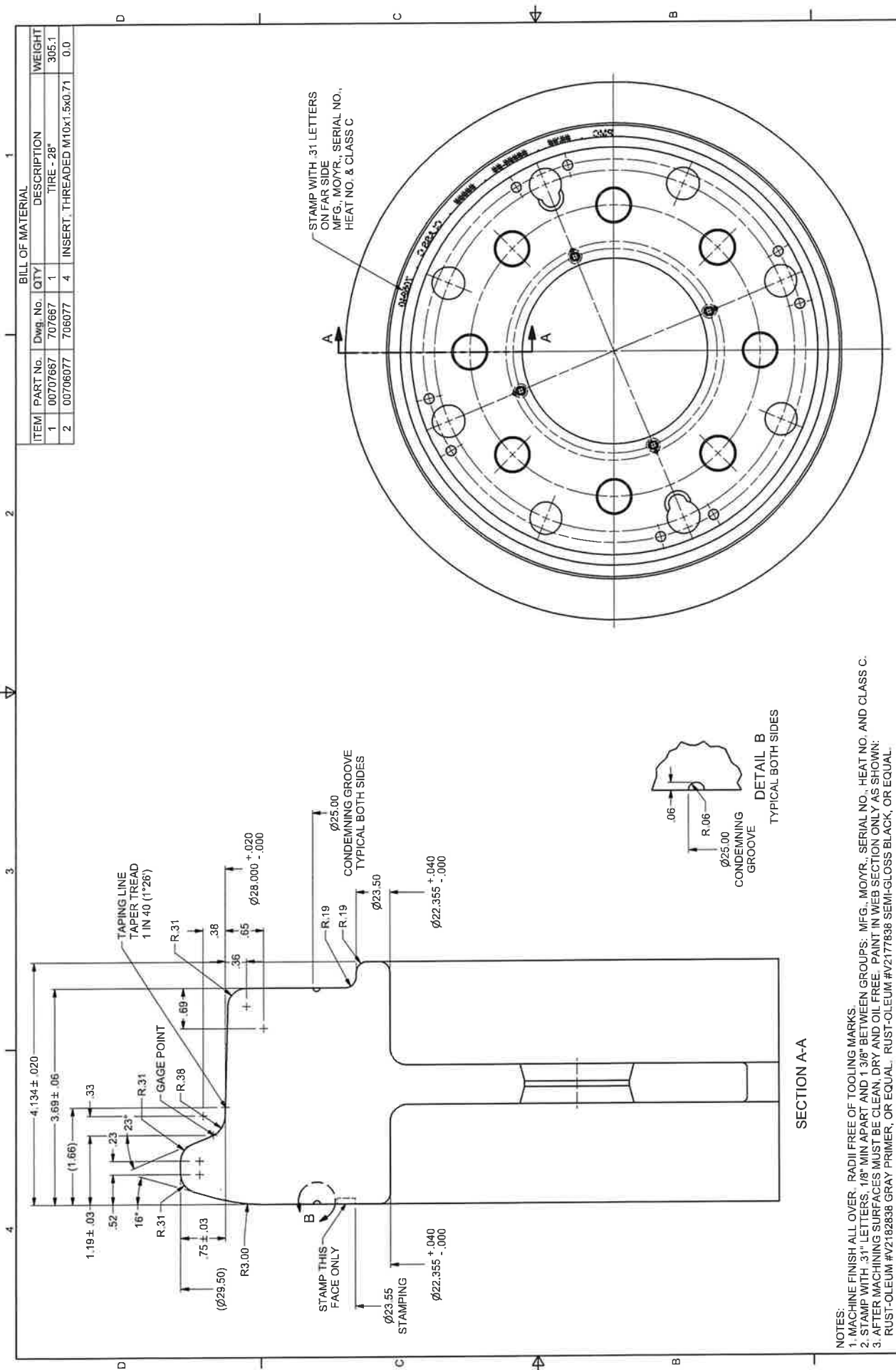

ITEM	PART NO.	Dwg. No.	QTY	DESCRIPTION	WEIGHT
1	00707667	707667	1	TIRE - 28"	305.1
2	00706077	706077	4	INSERT, THREADED M10x1.5x0.71	0.0

STAMP WITH 31 LETTERS ON FAR SIDE MFG. MOYR., SERIAL NO., HEAT NO. & CLASS C

SECTION A-A

DETAIL B
TYPICAL BOTH SIDES

NOTES:
 1. MACHINE FINISH ALL OVER, RADII FREE OF TOOLING MARKS.
 2. STAMP WITH 31" LETTERS, 1/8" MIN APART AND 1.3/8" BETWEEN GROUPS. MFG. MOYR., SERIAL NO., HEAT NO. AND CLASS C.
 3. AFTER MACHINING SURFACES MUST BE CLEAN, DRY AND OIL FREE. PAINT IN WEB SECTION ONLY AS SHOWN: RUST-OLEUM #V2182838 GRAY PRIMER, OR EQUAL. RUST-OLEUM #V2177838 SEMI-GLOSS BLACK, OR EQUAL. STAIN REMAINDER OF TIRE.

CUSTOMER DRAWING

ST. CHARLES NEW ORLEANS

REVISION

0	00707667	707667	0
---	----------	--------	---

PARTICIPANT INFORMATION FORM

All offerors are required to submit the information contained on this form. This information is a condition of submitting an offer to the RTA. Offerors must insure that **ALL** sub-contractors, sub-contractors or others at all tiers, which are proposed to be used or used under any agreement issued by RTA have submitted an executed copy of this form. RTA is required to maintain this information by the Federal Transit Administration and it is not subject to waiver.

Firm Name Brookville Equipment Corp

Firm Address 175 Evans St. Brookville, Pa 15825

Telephone Number 814-849-2000

Fax Number _____

E-Mail Address deberts@brookvillecorp.com

Firm's status as Disadvantaged Business Enterprise (DBE) or Non-DBE Non-DBE

Age of the firm 103 years

Annual gross receipts of the firm N/A

Prime or Sub-Contractor Sub-contractor

NAICS code (s) _____

I certify to the best of my knowledge that the above information is true and correct:

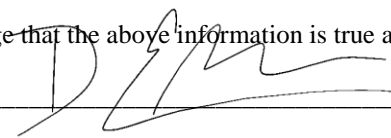
Signature 

Title Parts Sales Account Manager

Date 2/14/23

RTA Project No. IFB 2023-003

FAILURE TO PROVIDE AN EXECUTED COPY OF THIS FORM AS STIPULATED HEREIN MAY PRECLUDE YOUR OFFER FROM CONSIDERATION FOR AWARD.

CERTIFICATION OF RESTRICTIONS ON LOBBYING

Dan Eberts, Parts Sales Account Manager

I, _____ hereby certify on

(Name and Title of Offeror Official)

Brookville Equipment Corporation

behalf of _____ that:

(Name of Offeror)

- (1) No Federal appropriated funds have been paid or will be paid, by or on behalf of the undersigned, to any person for influencing or attempting to influence an officer or employee of any agency, a Member of Congress, an officer or employee of Congress, or an employee of a Member of Congress in connection with the awarding of any Federal contract, the making of any Federal grant, the making of any Federal loan, the entering into of any cooperative agreement, and the extension, continuation renewal, amendment, or modification of any Federal contract, grant, loan or cooperative agreement.
- (2) If any funds other than Federal appropriated funds have been paid or will be paid to any person for influencing or attempting to influence an officer or employee of any agency, a Member of Congress, an officer or employee of Congress, or an employee of a Member of Congress in connection with this Federal contract, grant, loan, or cooperative agreement, the undersigned shall complete and submit standard Form-LLL, "Disclosure Form to Report Lobbying," in accordance with its instructions.
- (3) The undersigned shall require that the language of this certification be included in the award documents for all sub-awards at all tiers (including subcontracts, sub-grants, and contracts under grants, loans, and cooperative agreements) and that all sub-recipients shall certify and disclose accordingly.

This certification is a material representation of fact upon which reliance is placed when this transaction was made or entered into. Submission of this certification is a prerequisite for making or entering into this transaction imposed by section 1352, title 31, U.S. Code. Any person who fails to file the required certification shall be subject to a civil penalty of not less than \$10,000 and not more than \$100,000 for each such failure.

Executed this 13th day of January, 2025.

BY [Signature]

Witnesses: _____
(Signature of Authorized Official)

Lori B. Johnston
(Title of Authorized Official)

My commission expires: 11-22-2026

Sworn to and subscribed before me on this 13th day of January, 2025.

Notary Public In and For Jefferson County Parish/County

State of Pennsylvania

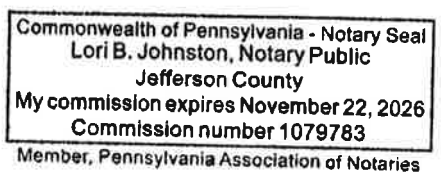

NON-COLLUSION AFFIDAVIT

STATE OF Pennsylvania

PARISH OF Jefferson County

Dan Eberts

, being first duly sworn, deposes and says that:

- (1) He is (Owner) (Partner) (Officer) (Representative) or (Agent), of Brookville Equipment Corp, the Contractor that has submitted the attached bid;
- (2) Such Bid is genuine and is not a collusive or sham Bid.
- (3) The attached bid is not made in the interest of or on behalf of any undisclosed person, partnership, company association, organization or corporation; that such bid is genuine and not collusive or sham; that said bidder has not, directly or indirectly, induced or solicited any other bidder to put in a false or sham bid, and has not, directly or indirectly colluded, conspired connived or agreed with any bidder or anyone else to put on a sham bid, or refrain from bidding; that said bidder has not in any manner, directly or indirectly, sought by agreement, communication or conference with anyone to fix the bid price of said bidder or any other bidder, or to fix any overhead, profit, or cost element of such bid price or that of any other bidder, or to secure any advantage against RTA or anyone interested in the proposed contract; that all statements contained in such bid are true; that said bidder has not, directly or indirectly, submitted his bid price or any breakdown thereof or the contents thereof, or divulged information or data relative thereto, or paid or agreed to pay, directly or indirectly, any money or other valuable consideration for assistance or aid rendered or to be rendered in procuring or attempting to procure the contract above referred to, to any corporation, partnership, company, association, organization or to any member or agent thereof, or to any other individual; and further that said bidder will not pay or agree to pay directly or indirectly, any money or other valuable consideration to any corporation, partnership, company, association, organization or to any member or agent thereof, or to any individual, for aid or assistance in securing contract above referred to in the event the same is awarded to said bidder.

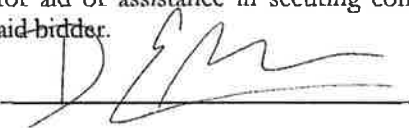
Signed: 
 Title: Parts Sales Account Manager

Sworn to me and subscribed in my presence this 13th day of January 2025, A.D.,

 NOTARY PUBLIC
 My commission expires: 11-22-2026

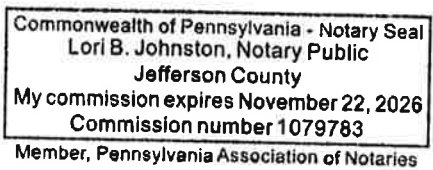

WHEELS, CARBON STEEL

Specification M-107/M-208

Adopted: 1962; Last Revised: 2011

1.0 SCOPE

These specifications cover one-wear, two-wear, and multiple-wear wrought and cast carbon steel wheels for locomotives and cars—Classes L, A, B, C, and D (heat-treated) wheels used in interchange service. All freight car wheels manufactured for AAR interchange service must be heat-treated and of a low-stress design.

1.1 Class B, C, or D wheels must be used for freight cars in interchange service.

1.2 Class B, C, or D wheels are recommended for use on locomotives.

1.3 For passenger car service, the various classes are intended generally as follows:

Class L—High-speed service with more severe braking conditions than other classes and light wheel loads.

Class A—High-speed service with severe braking conditions, but with moderate wheel loads.

Class B—High-speed service with severe braking conditions and heavier wheel loads.

Class C—(1) Service with light braking conditions and heavy wheel loads.

(2) Service with heavier braking conditions where off-tread brakes are employed.

2.0 DESIGN

2.1 Standard wheel types and tread and flange contours for freight car and locomotive steel wheels shall be as shown in this specification. Interchangeability requirements and tolerances and tread and flange contours for the authorized wheel types are shown in Figs. B.8 through B.14. The interchangeability requirements and tolerances are generally limited to those required to ensure the wheel is compatible with the standard axles, bearings, side frames, and track. In the event that design constraints other than these are shown, the wheel producer may request an exception or change by application, with supporting data, to the AAR Technical Services Division (hereinafter termed AAR). Staff will, in turn, submit the application to the Wheels, Axles, Bearings, and Lubrication (WABL) Working Committee (hereinafter referred to as the “Committee”) for review.

2.2 In the event any company feels there is a need for a wheel type not currently listed, an application, with supporting data, should be made to the AAR, who will obtain the decision of the Committee.

3.0 Authorization for delivery for interchange use of any AAR wheel type must be obtained from the AAR as described in Appendix A.

4.0 Qualification as a manufacturer of wheels for use in AAR interchange service must be in accordance with Appendix B. Qualification is effective until revoked for cause by the Committee. Failure to maintain reasonable quality standards in manufacturing is an example of cause.

5.0 MANUFACTURE

5.1 Discard

A sufficient discard shall be made from the steel used for the manufacture of all steel wheels to ensure freedom from piping and undue segregation.

5.2 Temperature Control

During manufacture of all wheels, necessary care in the regulation of temperature gradients shall be exercised to prevent the development of internal defects or injurious stresses.

6.0 HEAT TREATMENT

6.1 All wheels must be rim-quenched and tempered.

6.2 Rim-Quenching Treatment

All wheels shall be allowed to cool to a temperature below the critical range and uniformly reheated to the proper temperature to refine the grain, and then the rims shall be quenched. Following quenching, the wheels shall be charged into a furnace for tempering to meet the requirements of paragraph 10.0 and subsequently cooled under controlled conditions.

7.0 SHOT PEENING

7.1 Scope

This section covers shot peening of steel wheels to provide improvement in plate fatigue strength.

7.2 Requirements

7.2.1 Shot

The shot shall be SAE No. 550 or larger hardened steel as specified in SAE J827.

7.2.2 Shot Size Control

The peening machines shall be equipped with a separator for continuously removing broken shot. Sufficient new shot shall be added to ensure that a minimum of 85% of No. 550 or larger shot is maintained in the machines at all times.

7.2.3 Peening Intensity

The peening intensity shall be sufficient to produce an average arc height of not less than 0.008 (.0075 +) Almen C on the front plate near the hub fillet and on the back plate near the rim fillet of wheels of the standard design and at back plate hub fillet and front plate rim fillet of the reverse plate design. The area to be peened is defined as the plate area extended approximately one-half of the way into the hub and rim fillet radii on the front and on the back of the wheel.

7.2.3.1 Arc Height Measurement

Measurements of arc height shall be made in accordance with SAE Standards J442 or SAE Recommended Practice J443.

7.2.4 Coverage

The minimum peening time shall be sufficient to ensure that full coverage is attained on the Almen C strip as defined in SAE Recommended Practices J443, Alternate Procedure, or MIL-S-13165 C, Paragraph 6.11

7.2.5 Sequence

Shot peening will be performed on all wheels and after any corrective surface preparation on the plate area. Plate area is defined in paragraph 7.2.3. Peening may be performed prior to inspection.

AAR Manual of Standards and Recommended Practices

Wheels and Axles

M-107/M-208

7.2.6 Portable Peeners

A portable peening device may be used to re-peen small reconditioned areas (no larger than 6 in.²) on wheel plate surfaces, excluding the critical fillet areas (front hub and back rim fillets of wheels of standard designs and back hub and front plate fillets of wheels of reverse plate design). The portable equipment must be capable of peening an Almen C strip to develop the required average arc height of not less than 0.008 in. with a reasonable time of peening. Peening time of wheel plates must be at least as long as the time required to develop the 0.008-in. arc height. The equipment must be tested on an Almen C strip each 8-hour shift that the portable peener is used. A record of the Almen C test results shall be maintained.

7.3 Quality Assurance Provisions

7.3.1 Wheel Surface Condition

The peened appearance of rim and hub shall not be cause for rejection.

7.3.2 Frequency of Test

Arc height determinations shall be made on Almen C strips attached to a test wheel at the beginning and end of each production run but not less than once in each eight operating hours.

7.3.3 Retest

If a test fails to meet the arc height requirements of 0.008 Almen C, two retests will be made. These retests shall be averaged with the first determination. The average shall be not less than 0.008, and no more than one value of the three shall be less than 0.008.

7.3.4 Repeening

When test values fail to meet the provisions of paragraph 7.3.3, corrective action shall be initiated and satisfactory test values secured before proceeding with production peening. If the average Almen value of the unsatisfactory test is 0.006 or 0.007, the last half of the wheels peened prior to the unsatisfactory test (but subsequent to a satisfactory test) shall be repeened with at least 1/2 exposure time. If the average Almen value is less than 0.006, all the wheels peened since the last satisfactory test shall be repeened with full exposure.

8.0 LADLE ANALYSIS

8.1 The steel shall conform to the following chemical requirements:

Table 8.1 Chemical requirements

Element	Ladle Analysis (%)			
	Class L	Class A	Class B	Class C
Carbon	0.47 max.	0.47–0.57	0.57–0.67	0.67–0.77
Manganese	0.60–0.90	0.60–0.90	0.60–0.90	0.60–0.90
Phosphorous	0.030 max.	0.030 max.	0.030 max.	0.030 max.
Sulfur	0.005–0.040	0.005–0.040	0.005–0.040	0.005–0.040
Silicon	0.15–1.00	0.15–1.00	0.15–1.00	0.15–1.00
Residual Elements				
Nickel	0.25 max. ^{a/}	0.25 max. ^{a/}	0.25 max. ^{a/}	0.25 max. ^{a/}
Chromium	0.25 max. ^{a/}	0.25 max. ^{a/}	0.25 max. ^{a/}	0.25 max. ^{a/}
Molybdenum	0.10 max. ^{a/}	0.10 max. ^{a/}	0.10 max. ^{a/}	0.10 max. ^{a/}
Vanadium	0.040 max. ^{a/}	0.040 max. ^{a/}	0.040 max. ^{a/}	0.040 max. ^{a/}
Copper	.35 max.	.35 max.	.35 max.	.35 max.
Aluminum	0.060 max.	0.060 max.	0.060 max.	0.060 max.
Titanium	0.03 max.	0.03 max.	0.03 max.	0.03 max.
Colunbium (niobium)	0.05 max.	0.05 max.	0.05 max.	0.05 max.

^{a/} If the manufacturer chooses to vary from the above limits for nickel, chromium, molybdenum, and vanadium, the following formula must be met:

$$930 - [570 \times \% \text{ carbon}] - [80 \times \% \text{ manganese}] - [20 \times \% \text{ silicon}] - 50 \times \% \text{ chromium} - [30 \times \% \text{ nickel}] - [20 \times \% \text{ molybdenum} + \% \text{ vanadium}] > 390$$

8.2 An analysis of each heat of steel shall be made by the manufacturer to determine the percentage of the elements specified in paragraph 8.1. This analysis shall be made on a test specimen taken during the pouring of the heat. The chemical composition thus determined, together with such identifying records as may be desired, shall be reported to the purchaser or purchaser's representative and shall conform to the requirements specified in paragraph 8.1.

8.3 Chemical Analysis

Chemical analysis of each heat of steel shall be made by one of the test methods listed below. All analyses should note which method is used for the carbon and/or chemical determinations.

8.3.1 Test Method 1

The carbon determinations should be one of the following test methods:

8.3.1.1 Total carbon by the combustion gravimetric method, ASTM E-350 "Standard Test Methods for Chemical Analysis of Carbon Steel, Low-Alloy Steel, Silicon Electrical Steel, Ingot Iron, and Wrought Iron."

8.3.1.2 Total carbon by the combustion thermal conductivity method, ASTM E-1019 "Standard Test Methods for Determination of Carbon, Sulfur, Nitrogen, Oxygen, and Hydrogen in Steel and in Iron, Nickel, and Cobalt Alloys."

8.3.1.3 Total carbon by combustion, followed by quantitative infrared analysis, ASTM E-1019 "Standard Test Methods for Determination of Carbon, Sulfur, Nitrogen, Oxygen, and Hydrogen in Steel and in Iron, Nickel, and Cobalt Alloys."

AAR Manual of Standards and Recommended Practices

Wheels and Axles

M-107/M-208

8.3.2 Test Method II

ASTM E-415 “Standard Test Method for Optical Emission Vacuum Spectrometric Analysis of Carbon and Low-Alloy Steel.”

8.4 Check Analysis

An analysis may be made by the purchaser from finished wheels selected by the purchaser from each heat in question. For a serviceable wheel, the sample must be obtained from the rim face in a manner that will not impair the usefulness of the wheel. No drilling of the finished wheel plate is permitted. For a broken wheel, the sample may be taken from any part of the wheel mid-radius to tread. When turnings are used, they must be thoroughly mixed together and must be clean and free of oil, scale, and other foreign substances. The check analysis shall not be used in lieu of the ladle analysis to qualify an individual heat.

8.4.1 Sampling Method

When wheel blocks or whole wheels are not available for chemical analysis, the laboratory conducting the chemical analysis shall follow a standard sampling method. This standard method of sampling shall be ASTM E-1806, “Standard Practice for Sampling Steel and Iron for Determination of Chemical Composition.” Then use either ASTM E-350, E-1019, or ASTM E-415 as specified in paragraph 8.3 for chemical analysis of the sample.

8.4.2 Check Analysis—Permitted Variance from Specified Ranges

The following tolerances are permitted between the check analysis and the specified chemical limits:

Table 8.2 Check analysis variation from ladle analysis

Carbon ±0.04	Manganese ±0.03	Phosphorus +0.008	Sulfur ±0.005	Silicon ±0.05
-----------------	--------------------	----------------------	------------------	------------------

Nickel +0.03	Chromium +0.03'	Molybdenum +0.01	Vanadium +0.01	Copper +0.03	Aluminum +0.01	Titanium +0.05	Columbium +0.02
-----------------	--------------------	---------------------	-------------------	-----------------	-------------------	-------------------	--------------------

9.0 INTERIOR CONDITION/MICROCLEANLINESS STANDARDS

9.1 Sample Frequency

The metallurgical cleanliness of the wheel steel shall be determined from samples taken from randomly selected finished wheels representing the heat. A minimum of one 33-in. wheel and one 36-in. wheel of different heats produced quarterly per facility shall be tested.

- Facilities that produce only 33-in. or 36-in. wheels shall test two wheels of different heats quarterly.
- Facilities producing different size wheels to AAR specifications during a quarter shall test at least two wheels of different heats during the subject quarter.
- Facilities not producing wheels to AAR specifications during four successive quarters shall, at a minimum, test at least two wheels from a heat specially produced to AAR specifications for the scheduled facility certification continuation inspection once a year.

The purchaser reserves the right to more frequent testing should it be deemed necessary by mutual agreement between the purchaser and producer.

9.2 Sample Size and Location

A minimum of six samples shall be taken from each wheel tested approximately equidistant around the circumference of the wheel. Each sample shall be 7/8 in. long in the circumferential direction (the rolling direction), 3/4 in. wide in the axial direction (the rim width), and 1/2 in. thick in the radial direction (the rim thickness). The circumferential surface for microcleanliness evaluation shall be located 1/2 in. below the wheel tread and 2 1/2 in. to 3 1/4 in. from the back rim face. Dimension tolerances are ±1/8 in.

9.3 Sample Preparation and Evaluation

9.3.1 Each 7/8 in. × 3/4 in. × 1/2 in. sample shall be carefully prepared and evaluated to ASTM Standard Practice E1245. The flicker method shall be used to establish the correct setting of the gray-level threshold limits.

9.3.2 The total area evaluated for each sample shall be not less than 1/4 in.² or 161 mm². All inclusions greater than 2.5 μm, regardless of inclusions being exogenous or indigenous in the plane of polish, shall be counted. The WABL Committee must approve alternates to this method.

9.3.3 Effective January 1, 2008, average and worst field area percentage oxides, voids, and sulfides will be recorded. The AAR shall be advised quarterly when the six samples representative of the heat tested average more than 0.100% oxide plus voids; or the worst field area percentage of any one sample is more than 0.750% oxide plus voids; or 0.750% sulfides. If AAR is advised in two successive quarters, the provisions of *AAR Manual of Standards and Recommended Practices*, Administrative Standards, Standard S-060, paragraph 5.3, shall apply. In such cases, a special facility inspection may be required to demonstrate that the root cause has been identified and addressed.

9.3.4 Each sample shall be permanently marked according to heat and wheels represented and retained for a period of 1 year after the wheels are shipped. Records of test results shall be kept for 10 years after the wheels are shipped. Inspection results will be available for review by the AAR or other interested parties. AAR or other interested parties may have the test samples evaluated by other accredited laboratories at their expense.

10.0 BRINELL HARDNESS

10.1 The hardness of the rim, when measured in accordance with the requirements of paragraph 10.2, shall show the following values:

Table 10.1 Brinell hardness of rim

Class	Minimum Hardness	Maximum Hardness
L	197 BHN	277 BHN
A	255 BHN	321 BHN
B	302 BHN	341 BHN
C	321 BHN	363 BHN
D	341 BHN	415 BHN

Note: Class D alloy steel wheels must meet all chemical requirements for Class C wheels and have approval of the AAR WABL Committee.

10.2 Method of Measurement

Measurement must be made in accordance with ASTM E-10 (latest revision) on the front face of the rim with the edge of the impression not less than 3/16 in. from the radius joining face and tread. Before making the impression, any decarburized metal shall be removed from the front face of the rim at the point chosen for measurement. The surface of the wheel rim shall be properly prepared to permit accurate determination of hardness.

IMPLEMENTED 03/2012

AAR Manual of Standards and Recommended Practices

Wheels and Axles

M-107/M-208

11.0 NUMBER OF TESTS

11.1 Where continuous heat-treating furnaces are used, BHN measurements shall be made on 10% of the wheels from each heat. Where batch-type heat-treating furnaces are used, BHN measurements shall be made on 10% of the wheels from each heat-treatment lot. For batch-type heat-treating, at least one wheel from each heat in the heat-treatment lot must be tested. For either heat-treatment process, BHN measurements must be made on a minimum of one wheel in a heat or heat-treatment lot of 10 or less, and on a minimum of 2 wheels in a heat or heat-treatment lot of 11 to 20.

11.2 If all the wheels tested meet the requirements of paragraph 10.0, all of the wheels represented shall be accepted.

11.3 If any wheel tested fails to meet the requirements of paragraph 10.0, it shall be checked by making two additional hardness measurements, one on each side of the point first measured and each approximately 1 in. from that point. If both of these check measurements meet the requirements of paragraph 10.0, the wheel shall be considered to have met the requirements of paragraph 10.0.

11.4 When continuous heat-treating furnaces are used, should any of the wheels tested fail on check test to meet the requirements of paragraph 10.0, the manufacturer may test for individual hardness measurements all of the wheels of that heat in the lot submitted for inspection, and those meeting the requirements of paragraph 10.0 shall be accepted. Where batch heat-treating furnaces are used, should any of the wheels tested fail on check test to meet the requirements of paragraph 10.0, the manufacturer may test all of the wheels in the heat-treatment lot for individual hardness measurement, and those meeting the requirements of paragraph 10.0 shall be accepted.

11.5 On new wheel designs or existing designs to which process changes are made, hardness gradient tests shall be performed on a minimum of one wheel from each of the first five heats of steel produced. The hardness shall be taken per Fig. 11.1 utilizing an approved hardness test machine. Values shall meet the requirements as shown in Table 11.1.

Table 11.1 Acceptable hardness ranges

Class	Minimum	Maximum
B	285 HB	341 HB
	28 Rc	40 Rc
C	301 HB	363 HB
	30 Rc	42 Rc
D	321 HB	415 HB
	32 Rc	44 Rc

If values do not meet the requirements in Table 11.1, an additional five wheels from five heats shall be tested. All five wheels must meet the requirements in Table 11.1. If one or more wheels fail to meet the requirements in Table 11.1, testing per paragraph 11.5 shall be repeated after a process and/or design change is made. All wheels from heats that have a test wheel that failed to meet the requirements in Table 11.1 shall be reheat-treated, and one wheel from the heat shall be tested. If this wheel fails to meet the requirements in Table 11.1, all wheels from the heat shall be scrapped. Only one reheat treatment shall be allowed.

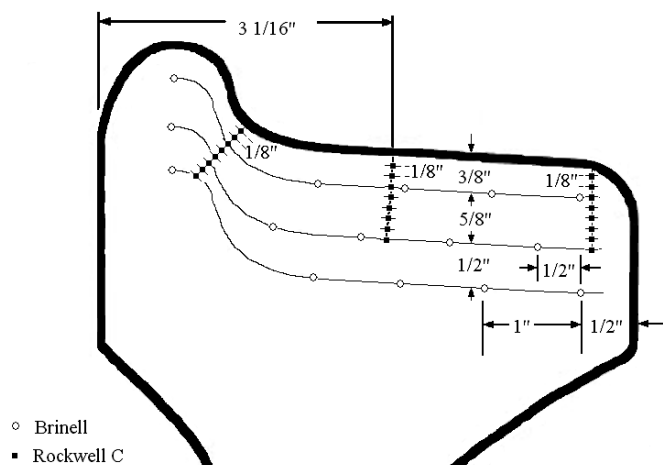

Fig. 11.1 Hardness mapping locations

12.0 RETREATMENT

Any wheel failing to meet the requirements of paragraph 10.0 may be retreated and tested in accordance with paragraph 11.0.

13.0 MATING

Wheels shall be measured and marked to the lower tape number until the next graduation is reached. Wheels shall be shipped in pairs of the same measured tape size.

14.0 GAUGES

The gauges and tapes shall conform to and be used as required by the standards of the AAR Technical Services Division Alternate tape gauging will meet or exceed the AAR measurement standard for taping wheels. The repeatability and reproducibility of all alternate gauges must be demonstrated.

15.0 PERMISSIBLE VARIATIONS

15.1 The wheels shall conform to the dimensions with tolerances as specified in Figs. B.8, B.9, B.11, and B.12 for freight car wheels and in Figs. B.8 and B.10 for locomotive wheels.

15.2 Where Figs. B.9 and B.10 allow a certain percentage of the wheels to vary from standard dimensions for tape size by a given amount, the percentage of such wheels shipped by any manufacturer shall not exceed this percentage during a calendar year. No individual purchaser may receive more than this percentage of his daily shipments of such wheels except by agreement with the manufacturer.

AAR Manual of Standards and Recommended Practices

Wheels and Axles

M-107/M-208

16.0 FINISH

16.1 Wheels shall be rough bored and shall not have black spots in the rough bore. Front hub face of wheels (1-W, 2-W, and MW) shall be parallel to the plane of the vertical reference line and may be smooth forged, cast, or machined. The back hub face may be smooth forged, cast, or machined.

16.2 The contour of tread and flange shall be as shown in Figs. B.11, B.12, or B.13 as applicable. Wrought steel wheels must be machined and finished smooth without excessive tool chatters. Cast steel wheels shall be as cast, machined, or ground, at the option of the manufacturer. Minimum and maximum flange thickness, height, and throat radii gauges shown in Standards S-661 and S-662 shall be used to check proper profile. Wheels that do not meet the criteria must be scrapped or recontoured.

16.3 Wheels must be free of all condemnable in-service defects. As-produced surfaces must be free from abrupt changes in surface contours. Spot grinding or machining to remove surface defects must not exceed a depth of 1/8 in. (0.125 in.; 3.2 mm). Sectional properties must meet all dimensional requirements following repair of surface defects. Repaired surfaces must have a maximum surface roughness of 500 μ in. prior to final shot peening. Repaired surfaces must provide a uniform transition to the as-produced surfaces.

16.4 Wheels shall not be covered with any substance to such an extent as to hide defects.

16.5 Wheel profile is to be checked using wide flange profile gauge shown in Fig. B.14. There will be no more than 1/32-in. variation from the profile.

17.0 MARKING

17.1 Identification markings shall be legibly stamped as shown in Figs. B.4 or B.5. Wheels for freight service must be hot stamped or cold stamped on the back hub face. If any stamped characters are missing or illegible, these shall be replaced by cold stamping in the proper place in the marking sequence. Passenger car wheels may be hot stamped or cold stamped on front or back (as specified by purchaser) hub face. When ordered, locomotive wheels may be hot or cold stamped on the back rim face; or hot or cold stamped on the front hub face; or hot or cold stamped on the back hub face providing finish machining will completely remove the markings on the back hub face. Locomotive wheels that are to receive final hub machining by the purchaser may be ordered with markings paint stenciled on the wheel plate. After final machining, the purchaser will cold stamp the markings on the front hub face. For wheels having raised cast-on markings, the markings shall be legible characters and be as shown in Fig. B.7. For all wheels, stamping should be centered approximately on the hub. No wheel manufactured after May 1, 2009, may be bored and applied with any portion of the wheel manufacturer's hub stamp closer than 1/8 in. from the inner hub diameter and no closer than 1/8 in. from the outer hub diameter. No wheel manufactured before May 1, 2009, may be bored and applied with any portion of the wheel manufacturer's hub stamp breaking over the edge of the inner or outer hub diameter.

17.2 The tape size of all wheels shall be paint stencilled on back plates in characters at least 1 in. high. An "H" shall also be paint stencilled on the front plate at least 1 in. in height on those wheels of curved plate, heat-treated configuration. Stencil paint must be white and have a minimum service life of 1 year.

17.3 Effective April 1, 2012, bar code labels must be affixed to all new freight car wheels in accordance with the *Manual of Standards and Recommended Practices*, Section L, Standard S-920.

IMPLEMENTED 01/2012

18.0 INSPECTION

18.1 The inspector representing the purchaser shall have free entry, at all times while the work on the purchaser's contract is being performed, to all parts of the manufacturer's works that concern the manufacture of wheels ordered. The manufacturer shall afford the inspector, free of charge, all reasonable facilities and necessary assistance to satisfy the inspector that the wheels are being furnished in accordance with these specifications. Internal defects are usually detected by ultrasonic testing. Such test shall be used in the manufacture of all wheels. The method to be followed and the equipment to be used shall comply with the requirements as shown in paragraph 18.4. Tests and inspection shall be made at the place of manufacture prior to shipment, unless otherwise specified.

18.2 The purchaser may make tests to govern the acceptance or rejection of the wheels in purchaser's own laboratory or elsewhere. Such tests shall be made at the expense of the purchaser.

18.3 All tests and inspections shall be so conducted so as not to interfere unnecessarily with the operation of the works.

18.4 Ultrasonic Inspection

For detecting internal discontinuities in the rim of all steel wheels, ultrasonic inspection shall be made by following either the procedures shown below or an AAR-approved equivalent. Equipment used in these procedures shall comply with the following requirements.

Each manufacturer shall maintain a documented test method and procedures for ultrasonic inspection of all railroad wheels manufactured under this specification.

18.4.1 Equipment

18.4.1.1 The instrument shall have a pulse echo receiver and shall operate at frequencies of 2 to 5 MHz required for the test method and type of equipment used.

18.4.1.2 The transducers shall be of the type whose composition and dimensions are appropriate for the test method used.

18.4.1.3 The ultrasonic inspection shall be performed with an automated scanning system. An automatic flaw alarm system shall be used in conjunction with the ultrasonic instrumentation.

18.4.1.4 A suitable couplant shall be used between the test surface and the transducer. The couplant shall be free of air bubbles. Rust inhibitors, softeners, and wetting agents may be added to the couplant.

18.4.2 Time of Inspection

Inspection shall be performed after final thermal processing.

AAR Manual of Standards and Recommended Practices

Wheels and Axles

M-107/M-208

18.4.3 Calibration

18.4.3.1 Calibration shall be conducted using a reference standard of a wheel or portion of a wheel rim containing simulated defects or other AAR-approved procedure. The instrument sensitivity level should be adjusted to produce an approximate full-scale reflection from the reference standards of paragraphs 18.4.3.2, 18.4.3.3, 18.4.3.4, and 18.4.3.5.

18.4.3.2 For axial testing of all wheels, the reference standard shall be a 1/8-in.-diameter flat-bottom hole generated perpendicular to the rim face and to a depth of 1 1/2 in. ($\pm 1/16$ in.) at the mid-thickness of the rim. See Fig. B.1

18.4.3.3 For radial testing, the reference standard shall be a 1/8-in.-diameter flat-bottom hole generated from the inside diameter of the rim perpendicular to the tread surface, and shall be a minimum of 1 1/4 in. from the tread surface. See Fig. B.2.

18.4.3.4 A distance amplitude correction (DAC) shall be used for axial and radial testing of wheels. To ensure detection, the DAC will be generated for each testing direction in the following manner.

Holes shall not be located close to each other so as to impede the response from each hole individually.

18.4.3.4.1 Axial

As a minimum, two additional 1/8-in.-diameter flat-bottom holes shall be generated at whatever depth the manufacturer chooses. The creation of the DAC shall be accomplished using the reference standard and the response(s) from additional holes. Typical depths for the three holes could be 1 1/2, 2 1/2, and 3 1/2 in. All holes should be generated from the front or back rim face. See Fig. B.1. Individual depth standards shall be permitted.

18.4.3.4.2 Radial

To facilitate creation of a DAC, as a minimum, one additional 1/8-in.-diameter flat-bottom hole shall be generated in one-wear and two-wear wheels, and, as a minimum, two additional 1/8-in.-diameter flat-bottom holes shall be generated in multi-wear wheels. Calibration shall be accomplished using the reference standard, and the response(s) from the additional holes shall be used to create the DAC. Table B.1 shows the depth of reference standard holes for the different wheel types. See Fig. B.2. Individual depth standards shall be permitted.

18.4.3.5 Alternate calibration standards may be used when authorized by the AAR WABL Committee. Manufacturer shall document and demonstrate the correlation between the 1/8-in.-diameter flat-bottom hole and the proposed alternate standard.

18.4.3.6 An alternate method for axial testing of cast steel wheels is to use loss of back reflection. The reference standard shall be a 3/8-in.-diameter concave bottom hole generated to a depth of 1/8 in. at the front rim face. See Fig. B.3.

18.4.3.7 Reference standards for the inspection of wheels shall be made from rim-treated wheel steel made by the same process as the wheels being inspected, i.e., wrought or cast. Reference standard need not be the same AAR design as the wheels being inspected.

18.4.3.8 Recalibration

Conduct ultrasonic calibration to ensure system conformance to required specifications. Check the ultrasonic system and calibration of the instrument per documented procedures using a calibration standard when any of the following occurs:

- Damage to any part of the ultrasonic system
- Change in transducers, cables, and other accessories
- Loss of power or equipment malfunction
- Whenever ultrasonic instrumentation is first turned on

18.4.3.9 System Verification and Test Results Validation

18.4.3.9.1 Conduct ultrasonic calibration checks to ensure system conformance to required specifications.

18.4.3.9.2 System calibration shall be verified per documented procedures using a calibration standard at least every 8 hours of operation. If the results from system verification are outside of system tolerance, assessment of previous inspections must be made and appropriate action taken. Action taken shall be supported by wheel reinspection data.

18.4.3.9.3 Records shall be maintained of system calibration and system verification.

18.4.4 Scanning

18.4.4.1 Wheels shall be inspected axially from either the front or back rim face and radially from the tread surface.

18.4.4.2 One or more transducers shall be designed and located to give maximum volumetric coverage of the rim cross-section both radially and axially.

Each manufacturer shall ensure optimum volumetric coverage for the test method and manufacturing process. Optimization of coverage is verified by using supplemental reference standard holes located in different areas of the rim, as shown in Figs. B.3.1 and B.3.2.

18.4.4.3 Scanning speed shall permit detection of reference standards at calibration level.

18.4.5 Rejection

18.4.5.1 Any wheel with a flaw indication equal to or larger than 25% of the reference standard at the estimated discontinuity depth shall be cause for rejection.

18.4.5.2 Any indication from discontinuity giving a loss of back reflection equal to or greater than the reference standard (covered in paragraph 18.4.3.6) during axial scanning shall be cause for rejection.

18.4.5.3 Ultrasonic indications that result from wheel geometry or spurious electrical signals shall not be valid cause for rejection.

18.4.5.4 The final disposition of rejectable wheel may be determined by manual testing of questioned areas. Wheel records and test results shall be maintained for wheels found to be conforming under this paragraph.

18.5 Magnetic Particle Inspection

18.5.1 Purpose

To supplement visual inspection of the surface of new wheels by detecting discontinuities that may be harmful to wheel service.

18.5.2 Scope

This test method covers the wet fluorescent magnetic particle inspection of the plates of wheels ordered to this specification.

AAR Manual of Standards and Recommended Practices

Wheels and Axles

M-107/M-208

18.5.3 Equipment

18.5.3.1 Magnetizing Apparatus

The magnetizing apparatus shall be capable of inducing suitable magnetic fields within the entire plate area of the wheel to facilitate the disclosure of both circumferentially and radially oriented discontinuities. The magnetizing currents used shall be large enough to induce magnetic fields of sufficient intensity to disclose surface discontinuities 1/4 in. long. The use of prod-type contacts is prohibited.

18.5.3.2 Lighting Apparatus

The inspection shall be performed in a darkened booth with the area of the wheel to be inspected illuminated with properly filtered black light. The black light shall have a predominant wavelength of 4000 Å to 3400 Å, and the intensity of the black light, measured at the surface to be inspected, shall be a minimum of 75 footcandle at point of inspection.

18.5.3.3 Inspection Medium

18.5.3.3.1 The bath or solution should be prepared using a suitable carrier fluid and fluorescent magnetic particles and renewed monthly or more often if contamination is noted in weekly tests. Each time the bath is renewed, the bath container should be cleaned out and the agitation and circulation system should be flushed with 1 or 2 gal of clean carrier. Filtering screens should be removed and cleaned by blowing with air. In preparing the new bath, only recommended materials should be used. The amount of powder should be carefully weighed out in accordance with the material manufacturer's recommendation and be added directly to the bath containing the correct amount of carrier. It is recommended that powder be added directly over the sump so that it will be drawn quickly into the pump and circulated. The amount of carrier and powder used and the date of preparation should be recorded on a regular form set up for this purpose, as outlined in paragraph 18.5.3.3.6.

18.5.3.3.2 Concentration and contamination of the bath solution should be tested weekly as follows: pump and agitation system should be operated for 20 minutes and then the solution should be run through a hose and nozzle for 30 seconds. Using a regular 100-mL centrifuge tube, fill the centrifuge tube with 100 mL of the solution. Allow the bath solution to settle for the time recommended by the manufacturer of the type of powder used, making sure that the tube is not subjected to excessive vibration during the settling period. Each horizontal division represents 0.1 mL, and a correct reading in volume of particles must be as stipulated by the powder manufacturer. The check also should note contamination caused by dirt, chips, or other foreign matter settling with the powder. Contamination also is indicated when the carrier appears to acquire more than usual fluorescence or when the magnetic particles appear to have lost fluorescent qualities. This condition can be readily observed when the settling tube is exposed to ultraviolet light. The readings obtained are to be shown on the regular report form as outlined in paragraph 18.5.3.3.6.

18.5.3.3.3 The ultraviolet light should be tested weekly using a light meter, such as a type having 75-footcandle scale with a 10× multiplying disc or equivalent or a meter that responds specifically to the ultraviolet range of 3650 Å (365 nm). The latter type meters are calibrated in microwatts per square centimeter. The meter should be held a fixed distance of 15 in. from the light source (from the black light filter surface to the meter-sensing element) and should have a minimum meter reading of 525 μW/cm².

18.5.3.3.4 The conversion factor from footcandles (for light meters) to microwatts per square centimeter is 5.7 times the footcandle reading (at 15 in. distance).

18.5.3.3.5 The maximum allowable footcandles will be left to the discretion of the user dependent on the degree of brilliance desired to obtain satisfactory inspection conditions. Before taking readings, it should be known that the glass black light filters are clean. Reports of this test are to be shown on regular form as outlined in paragraph 18.5.3.3.6.

18.5.3.3.6 A regular form should be prepared embodying the information to be shown on monthly and weekly tests as outlined above, and this form should be on hand at the wheel shop and available to AAR inspectors.

18.5.3.3.7 Prepackaged, self-contained solutions, including aerosol sprays, may be used provided that the following conditions are met:

18.5.3.3.7.1 The solution is agitated frequently to ensure that magnetic particles remain in solution.

18.5.3.3.7.2 A detectability test is performed daily on each package in use and a record is kept per paragraph 18.5.3.3.6. The test consists of inspection of a test wheel with a known crack of at least 1/4 in. long or an equipment manufacturer's approved test piece that will indicate and verify the following:

- Proper brilliance of ultraviolet light
- Proper concentration of bath solutions
- Proper magnetic power source and operation of equipment

Note: Test wheel or test piece must be thoroughly cleaned of the last test indicators before testing. This must be verified by ultraviolet light before the test is started.

18.5.4 Preparation for Inspection

The surface shall be scale free before magnetic particle inspection.

18.5.5 Detection of Discontinuities

This inspection shall be performed to detect discontinuities whose axes may be in any direction. Continuous or residual magnetization shall be used with adequate coverage by the inspection medium.

18.5.6 Time of Inspection

The magnetic particle inspection shall be performed following final machining or grinding on wheel plate.

18.5.7 Rejection

Rejection of magnetic particle discontinuity indications must take place if any plate surface indication is 1/4 in. in length or longer in any direction. Discontinuities may be removed by machining or grinding where sufficient stock remains. Such wheels shall be retested by magnetic particle inspection.

18.6 Personnel Requirements for Ultrasonic Inspection

18.6.1 All personnel engaged in ultrasonic operations will be qualified to NDT Level I according to the qualification requirements as defined by the American Society for Nondestructive Testing, Recommended Practice SNT-TC-1A, latest edition.

18.6.2 All personnel conducting inspection setups and machinery setups will be trained and qualified to meet the criteria for NDT Level II for ultrasonic testing as defined by the American Society for Nondestructive Testing, Recommended Practice SNT-TC-1A, latest edition.

18.6.3 Each manufacturer will employ the services of an individual who will be trained and qualified to meet the criteria for NDT Level III for ultrasonic testing as defined by the American Society for Nondestructive Testing, Recommended Practice SNT-TC-1A, latest edition.

19.0 CERTIFICATION

At the purchaser's request, a certification shall be made the basis of acceptance of the material. This shall consist of a copy of the manufacturer's test report that the material has been sampled, tested, and inspected in accordance with the provisions of the specification. Each certificate so furnished shall be signed by an authorized agent of the supplier or manufacturer.

AAR Manual of Standards and Recommended Practices
Wheels and Axles

M-107/M-208

20.0 REJECTION

20.1 Wheels represented by samples that fail to conform to the requirements of these specifications will be rejected.

20.2 Wheels that show injurious defects subsequent to original inspection and acceptance at the manufacturer's works, or elsewhere, will be rejected, and the manufacturer shall be notified.

21.0 REHEARING

Samples tested in accordance with this specification that represent rejected wheels shall be held for a period of 14 days from date of the test report. In case of dissatisfaction with the results of the tests, the manufacturer may make claim for a rehearing within that time.

22.0 This specification includes Appendices A and B; and Figs. B.1 through B.14.

APPENDIX A
AUTHORIZATION FOR DELIVERY OF WHEELS FOR AAR INTERCHANGE SERVICE

1.0 Each manufacturer must obtain an authorization for delivery of wheels for AAR interchange use from the Committee prior to delivery.

2.0 The manufacturer applying for delivery authorization must provide the AAR with an electronic copy of the following documentation.

2.1 A descriptive drawing of the wheel type as it will be produced. The descriptive drawing will provide the following information:

2.1.1 A full-scale drawing showing the wheel cross-section from center of the hub to top of the flange. The drawing may show either a single profile with tolerances or, preferably, two profiles, with one depicting the minimum inner tolerances and the other the maximum outer tolerances in such a way that a wheel section laid on the drawing would fall between the two profiles. This would allow analysis of wheels produced to this drawing.

2.1.2 A notation of the wheel type and heat-treatment classes of the wheels to be produced.

2.2 A brief description of the design analysis method and the results of the analysis. The preferred analytic procedure is that covered in S-660. If there is no design analysis, a statement should be made to this effect along with a summarization of the design considerations. If the applicant would like the AAR to perform the S-660 design analysis on a contract basis, the applicant should request details from the AAR.

2.3 A statement advising the specific areas in which the wheel design may not be compatible with normal shop machinery and handling equipment, standard storage facilities, and wheel transport cars in general use.

3.0 Authorization for the delivery of a wheel type will be approved by the Committee if deemed suitable for interchange service based on a review of wheel data submitted by the manufacturer. The initial authorization will be for the delivery of 32,000 wheels. If the manufacturer requests additional delivery authorizations, the second will be for 20,000 wheels (52,000 total) and the third will be for 20,000 wheels (72,000 total). Additional allotments or unconditional approval for unlimited quantities will be given after that, provided all required conditions are met.

3.1 A new wheel type (such as CH-36, CJ-36, or J-33) that is made for the first time by the requesting manufacturer will require the following prior to being granted unconditional approval. If necessary, WABL will designate a sponsor railroad to assist the manufacturer in meeting these requirements.

3.1.1 A minimum of 5,000 wheels installed from the first allotment will have been tracked to provide mileage and will have achieved 200,000 miles in service.

3.1.2 Ultrasonic testing to wheelshop requirements for turned wheels will be performed for 30 or more wheels with at least 200,000 miles of service and with sufficient rim metal to be reapplied. Provided all other criteria are met, upon successful completion of ultrasonic testing, conditional approval, unlimited quantity will be granted. The 30 wheels will then be placed in service and tracked. Ultrasonic testing to wheelshop requirements of turned wheels will be performed for 10 of the 30 wheels reapplied after 100,000 miles additional service. Provided all other criteria are met, upon successful completion of the ultrasonic testing, unconditional approval will be granted. Test costs will be paid by the proponent, and data provided in the form of C-scans will be captured with an AAR observer present and provided to WABL.

AAR Manual of Standards and Recommended Practices
Wheels and Axles

M-107/M-208

APPENDIX A

3.1.3 At least one out of every 1,000 wheels produced in the initial allotment will be tested for microcleanliness according to paragraph 9.0 of this specification. Results will be reported to the Wheels, Axles, Bearings, and Lubrication Committee Manager within 90 calendar days. Electronic reporting is preferred. Send results to

Email: wabl@aar.com Facsimile: 719-585-1895 Mail: AAR WABL Committee Manager Transportation Technology Center Inc. P.O. Box 11130 Pueblo, Colorado 81001

3.2 Each authorization after the initial authorization will be granted only after satisfactory performance is indicated by a review of service data submitted on the wheel by the manufacturer as well as service data from AAR records. Authorization may be withdrawn if service performance so dictates.

4.0 Changes to any wheel design by the producer must be reviewed by the Committee before delivery authorization may be granted.

APPENDIX B
QUALIFICATION OF MANUFACTURER'S PLANT AS A PRODUCER OF
WHEELS FOR AAR INTERCHANGE SERVICE

1.0 Applications for approval are to be submitted to the AAR. Applications shall be provided in electronic file format and must provide a general description of the facility and the equipment to be used in the production of wheels. In the event it is desired to deliver mounted wheel sets, information indicating that equipment is available to comply with the wheel mounting requirements of the *AAR Manual of Standards and Recommended Practices*, Section G, Part II, "Wheel and Axle Manual" should be included.

2.0 After review of the data submitted with the application, the Committee will authorize the applicant to contact the AAR for information concerning product testing. Normally this will consist of the applicant furnishing three wheels, at applicant's expense, for testing by the AAR. All costs are to be paid by the applicant upon notification of the testing charges.

3.0 Subsequent to the satisfactory completion of the tests and approval by the Committee of test results, the AAR will inspect the plant where the wheels are to be produced for proper equipment and, if mounted wheels are to be provided, an AAR inspection will be arranged for the wheel shop. These inspections will require that all out-of-pocket expenses be borne by the applicant. These inspections can be arranged concurrently with the test program if the applicant so requests.

4.0 All plants desiring to maintain their status as an AAR-approved manufacturer of wheels for use in AAR interchange service must be inspected yearly with costs of inspection to be borne by the wheel producer. Every effort will be made to inspect all plants in a given area at one time to minimize costs, which will be prorated among the companies inspected.

5.0 In the event that a facility ceases production for less than 1 year and has not received its scheduled annual inspection, an inspection of the facility is required prior to the delivery of any items for use in interchange service. In the event a plant ceases production of wheels for AAR interchange service for more than 60 days and less than 1 year, the AAR must be notified no later than 2 weeks prior to reopening. In the event a plant ceases production of wheels for AAR interchange service for more than 1 year, requalification will be required prior to delivery of any items for use in AAR interchange service. An AAR inspection of the plant will be required, and normally, the provisions of Appendix A will apply for all wheel designs that have been given an authorization in accordance with the procedure outlined in paragraph 2.0 and subparagraphs. The Committee may elect to require testing of wheels in accordance with Appendix B, paragraph 2.0.

6.0 In addition to the foregoing, wheel manufacturers must meet the requirements of the *AAR Manual of Standards and Recommended Practices*, Section J, Specification M-1003, "Specification for Quality Assurance."

7.0 All plants desiring to maintain their status as an AAR-approved manufacturer of wheels for use in AAR interchange service must also have their steel suppliers, shot peening, and heat-treating subcontractors inspected if they do not use their own facility. These inspections will be made in conjunction with the facility inspection, and the cost will be borne by the applicant.

8.0 Wheel manufacturers using a native language other than English are responsible for the accurate communication of all applicable AAR and customer requirements within the plant.

8.1 Plant practices and the final product must conform to the English language versions of any applicable standards or specifications.

8.2 Critical records are defined as the standards, internal procedures, and forms necessary to demonstrate compliance with this Specification M-107/M-208 and with *MSRP* Section J, Specification M-1003. Critical records must be kept up to date with production and be maintained in English.

AAR Manual of Standards and Recommended Practices
Wheels and Axles

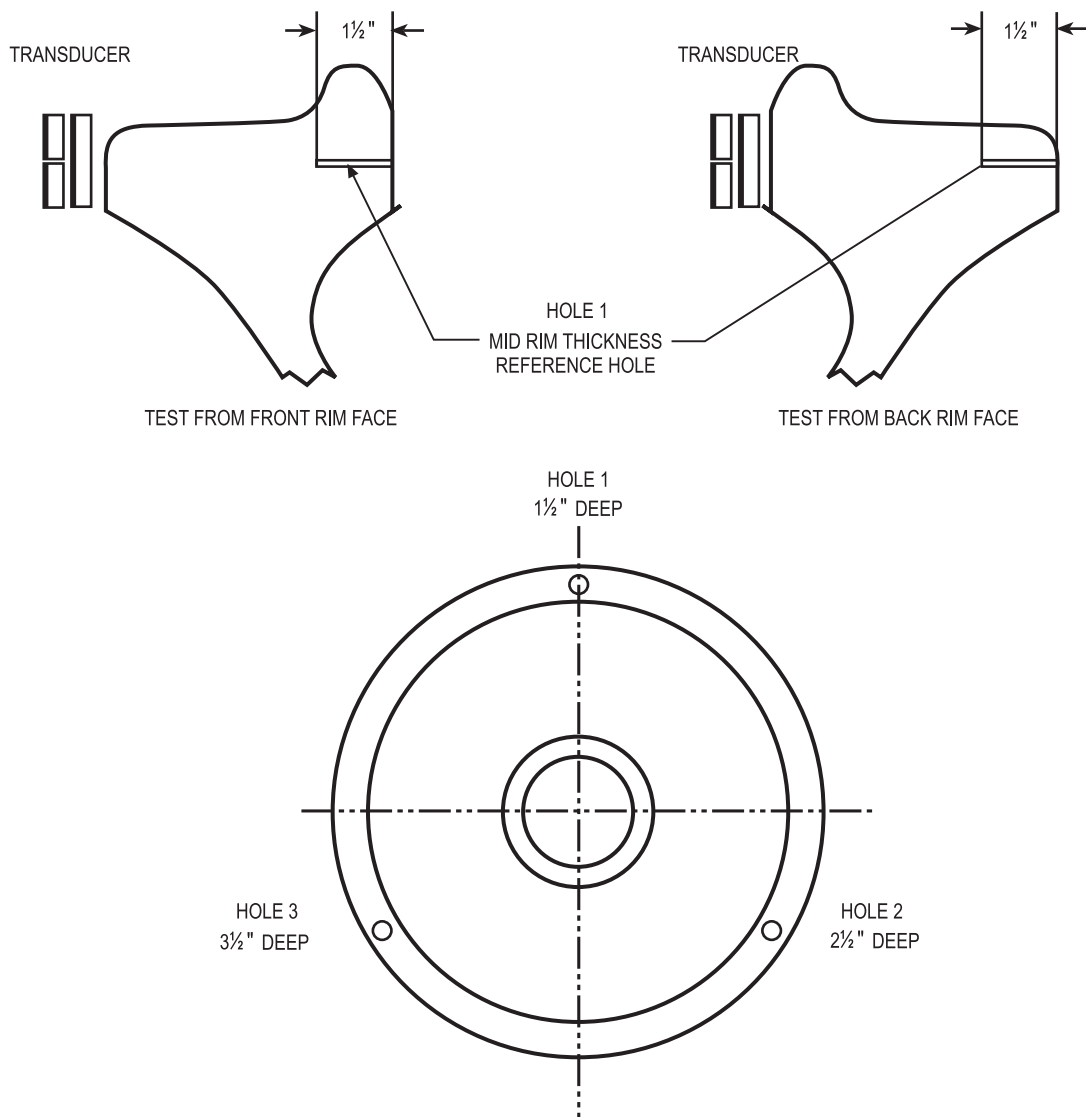

Fig. B.1 Typical reference standard for rim face ultrasonic test
Paragraphs 18.4.3.2 and 18.4.3.4
Hole #1 reference hole
Holes #2 and #3 used for distance amplitude correction (DAC)

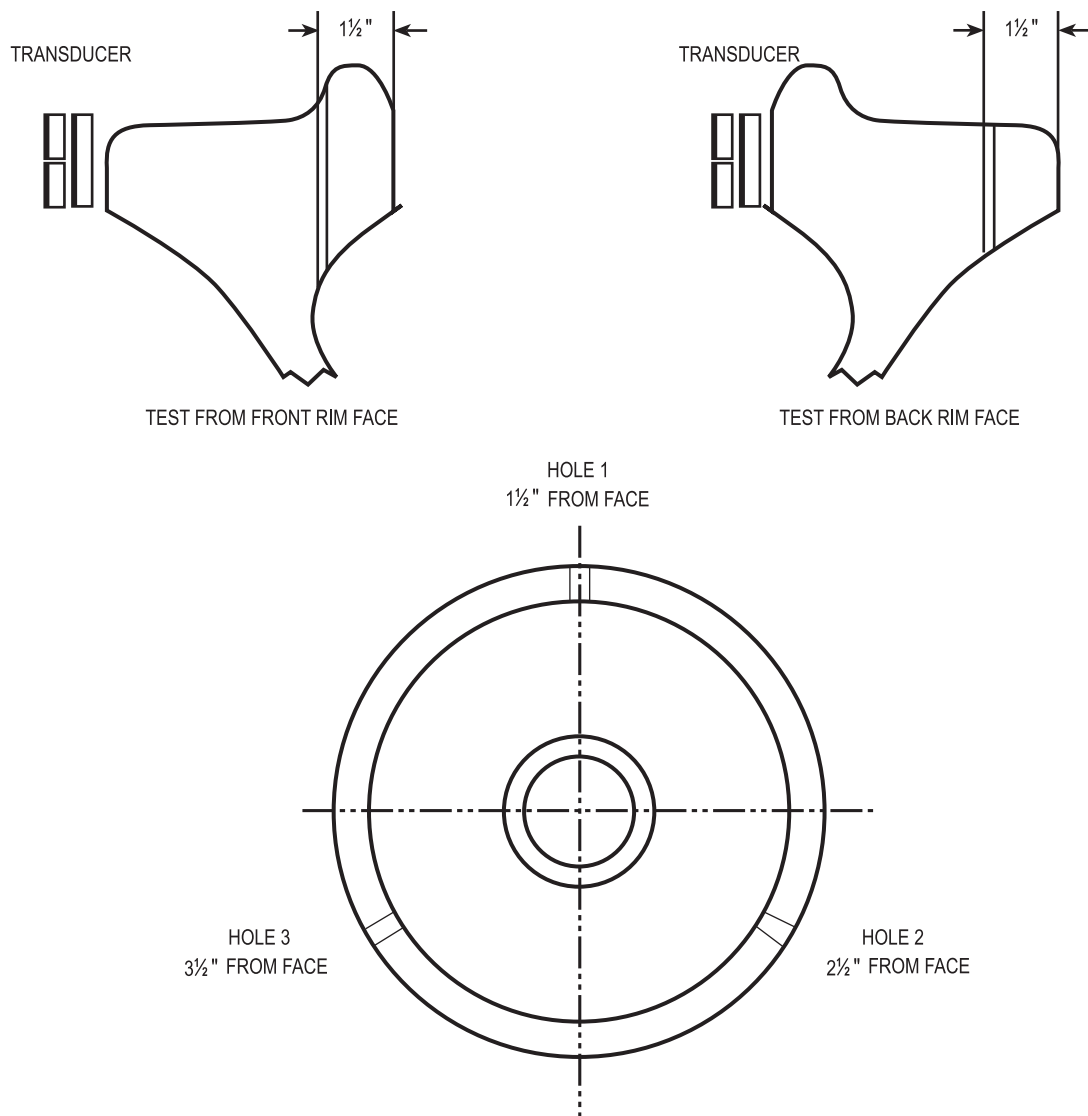

Fig. B.1.1 Axial rim test
Paragraphs 18.4.3.2 and 18.4.3.4.1
Alternate configuration for distance amplitude correction

**AAR Manual of Standards and Recommended Practices
Wheels and Axles**

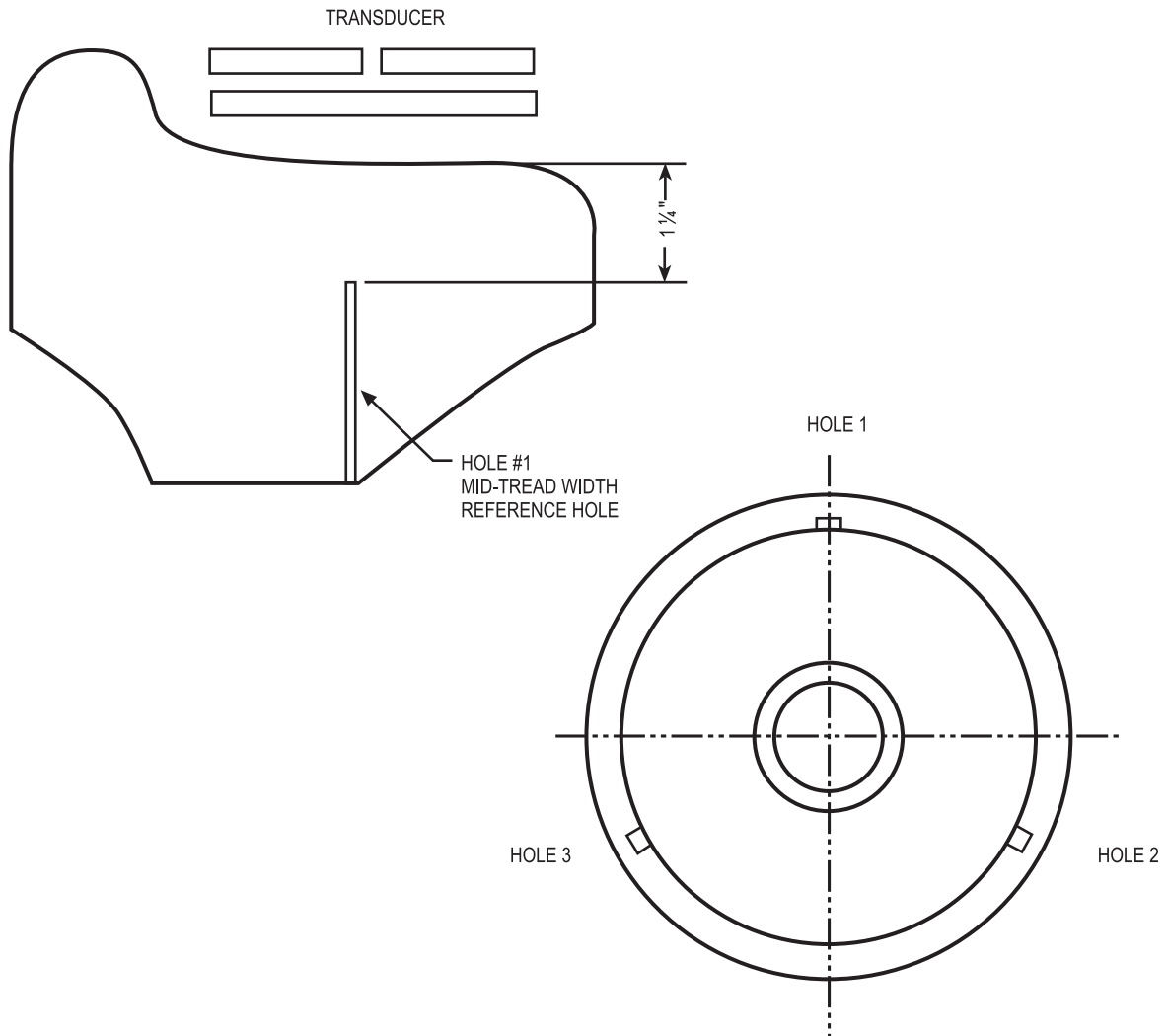

Table B.1

Wheel Design	Distance below Tread Surface		
	Reference Hole #1	Hole #2	Hole #3
One-wear two holes	1 1/4 in.	3/4 in.	
Two-wear two holes	1 1/4 in.	3/4 in.	
Multi-wear three holes	1 1/4 in.	3/4 in.	2 1/4 in.

Fig. B.2 Typical reference standard for rim tread ultrasonic test
 Paragraphs 18.4.3.3 and 18.4.3.4.2
 Hole #1 reference hole
 Hole #2 and #3 used for distance amplitude correction (see Table B.1)

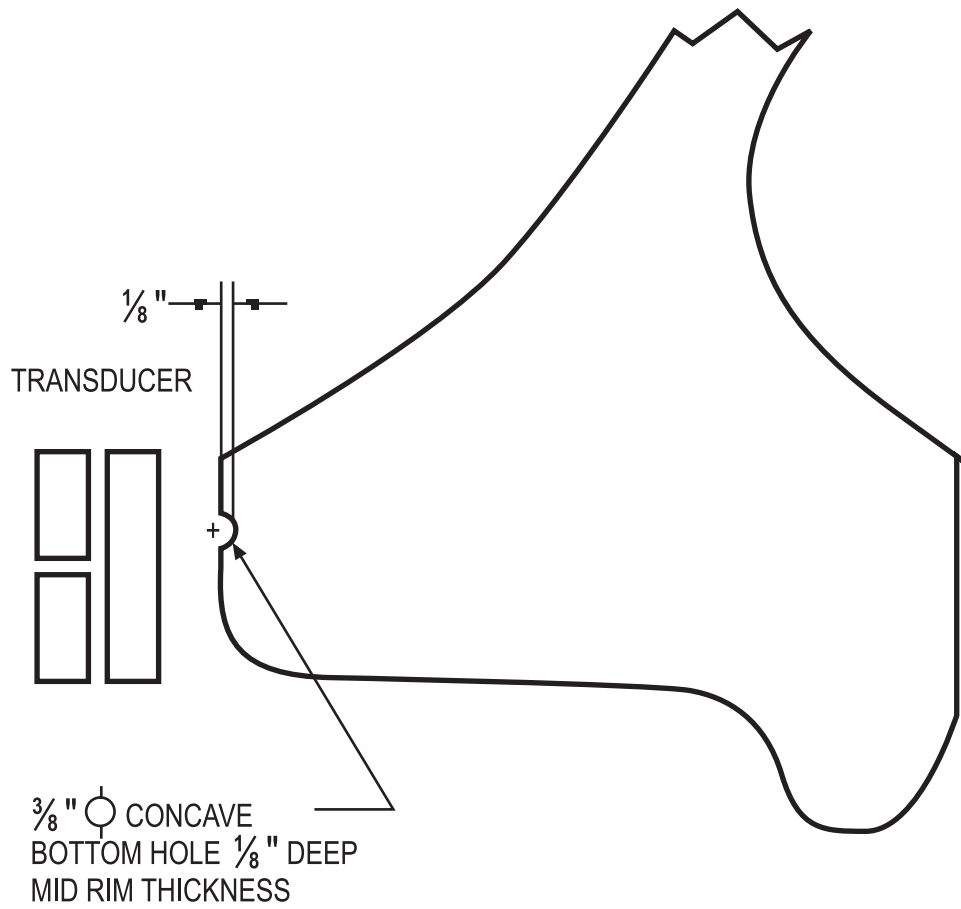

Fig. B.3 Axial rim test
Paragraph 18.4.3.6

AAR Manual of Standards and Recommended Practices
Wheels and Axles

M-107/M-208

APPENDIX B

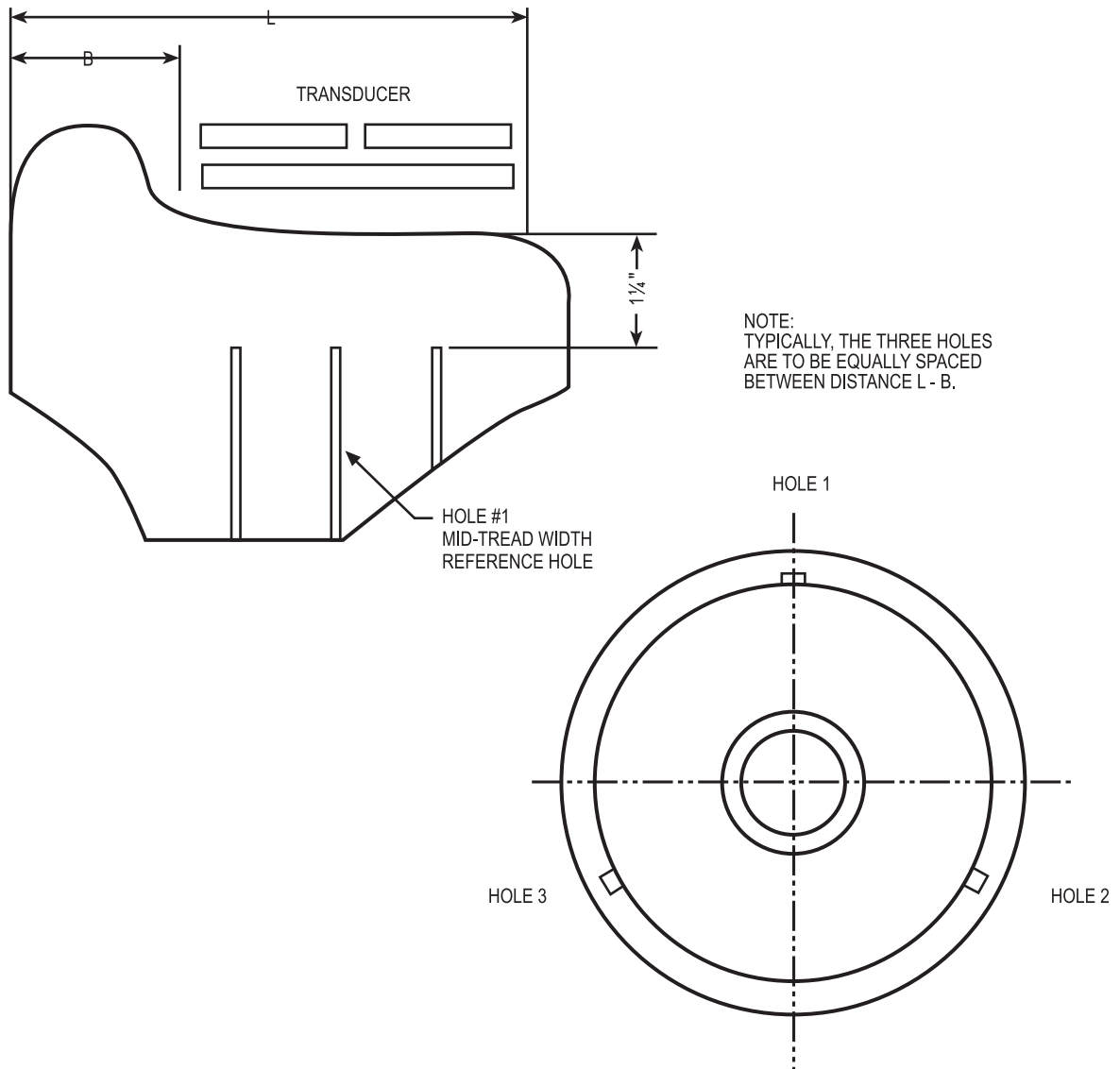
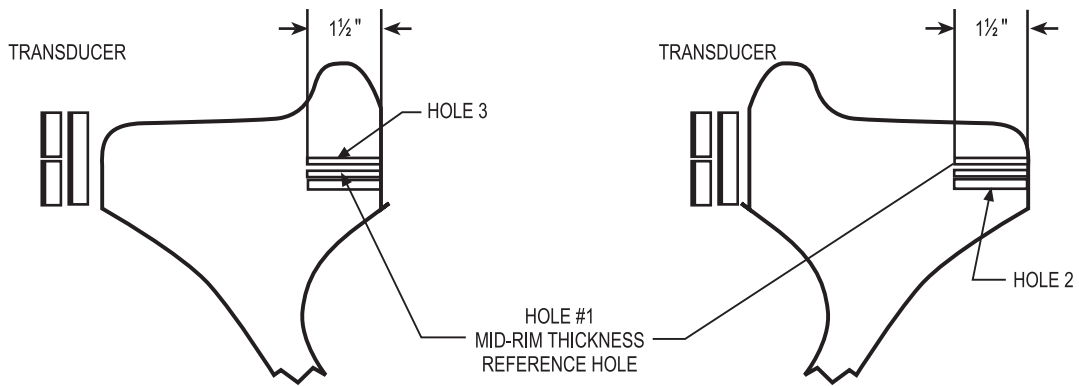

Fig. B.3.1 Tread rim test
Paragraph 18.4.4.2

AAR Manual of Standards and Recommended Practices
Wheels and Axles



NOTE:
TYPICALLY, THE THREE HOLES
ARE TO BE SPACED WITHIN THE
FLAT PORTION OF THE RIM FACE.

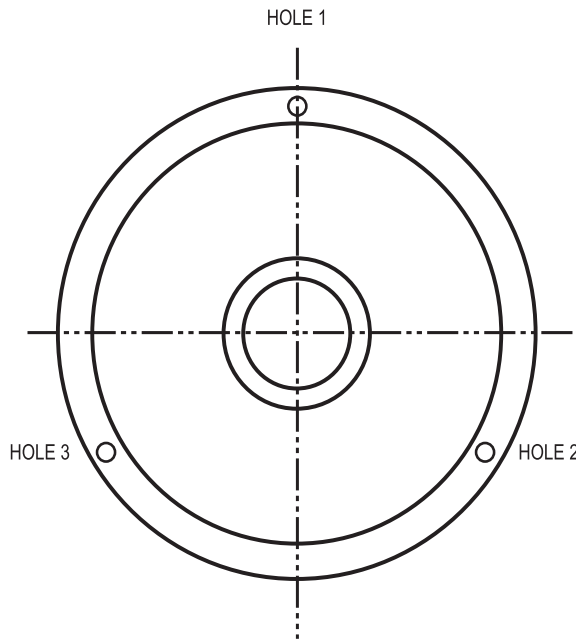
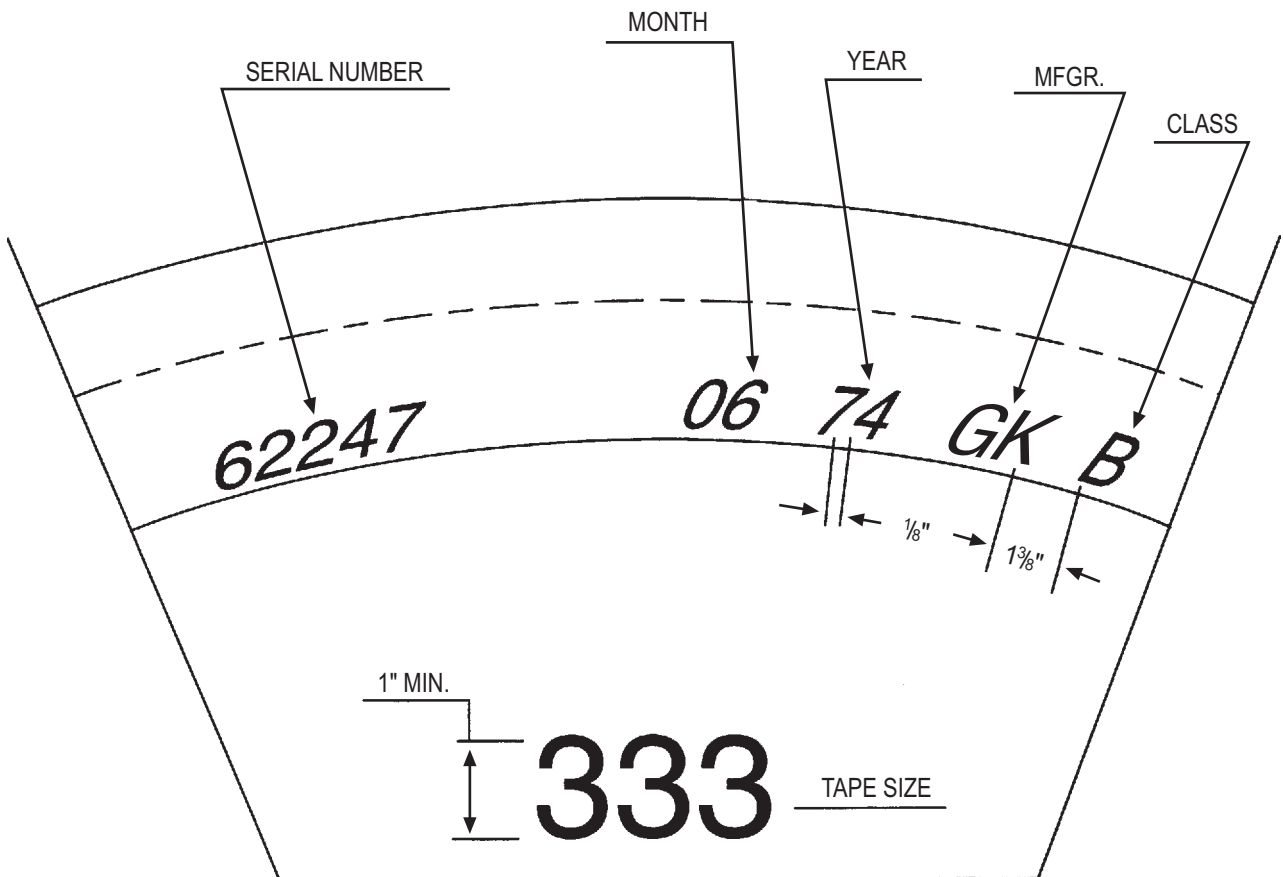

Fig. B.3.2 Axial rim test
Paragraph 18.4.4.2

AAR Manual of Standards and Recommended Practices
Wheels and Axles

M-107/M-208

APPENDIX B



- Note 1** Stamping is to consist of manufacturer's serial number, date of manufacture, manufacturer's identification, and class of heat treatment. Stamping is limited to 14 characters, and the design designation shall be stencilled on the back plate with paint using characters at least 1 in. in height.
- Note 2** Stamping is to be spaced a minimum of 1/8 in. between characters and 1 3/8 in. between groups. The stamping shall be located not less than 1/4 in. from the inner edge of the rim.
- Note 3** Dies used to produce characters shall be not less than 3/8 in. in nominal height at crest, and hot stamping shall be nominally 3/32 in. in depth. Italicized characters (sloping upward to right) shall be used.
- Note 4** All wheels will be marked for class using letters L, A, B, C, or D, as appropriate.
- Note 5** All stamped characters must be stamped with a low-stress die design to a minimum depth of 0.015 in. or an AAR-approved alternative.

Fig. B.4 Marking of locomotive wheels rim stamping
Paragraph 17.1

AAR Manual of Standards and Recommended Practices
Wheels and Axles

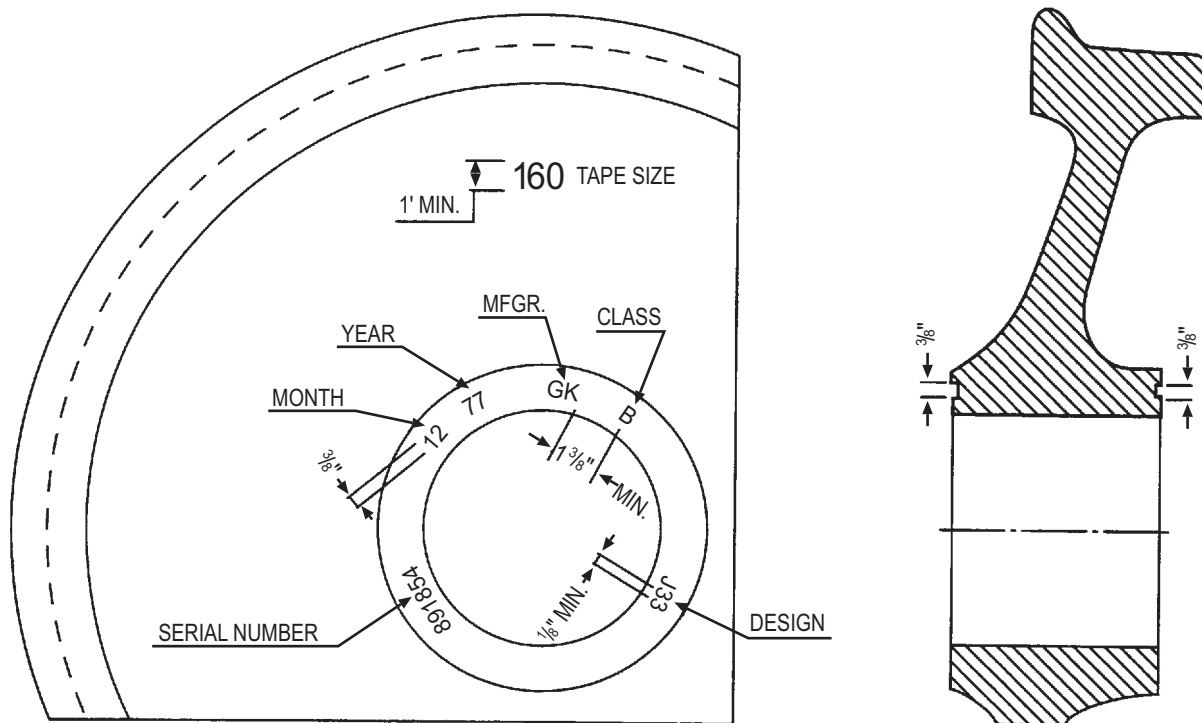

- Note 1** When ordered, locomotive wheels and wheels for passenger service may be ordered stamped on the front or back hub face. Wheels for freight service are stamped on the back hub face.
- Note 2** Stamping is to consist of manufacturer's serial number, date of manufacture, manufacturer's identification, class of heat treatment, and design designation in the order shown above. The hub stamping of locomotive wheels may be applied by the purchaser after final machining of the hub. Wheels that are to be marked by the purchaser should be furnished with all marking stencilled on the front plate with paint using characters at least 1 in. in height.
- Note 3** Stamping is to be spaced a minimum of 1/8 in. between characters and a minimum of 1 3/8 in. between groups and located approximately central of the hub face. No wheel manufactured after May 1, 2009, may be bored and applied with any portion of the wheel manufacturer's hub stamp closer than 1/8 in. from the inner hub diameter and no closer than 1/8 in. from the outer hub diameter. No wheel manufactured before May 1, 2009, may be bored and applied with any portion of the wheel manufacturer's hub stamp breaking over the edge of the inner or outer hub diameter.
- Note 4** Stamps used to produce characters shall be not less than 3/8 in. in height and shall not have sharp edges.
- Note 5** All wheels will be marked for class using letters L, A, B, C, or D, as appropriate.
- Note 6** The three groups (1) design; (2) serial number; and (3) date of manufacture, manufacturer, and class will be spaced approximately equidistantly around the hub face.
- Note 7** All stamped characters must be stamped with a low-stress die design to a minimum depth of 0.015 in. or an AAR-approved alternative.

Fig. B.5 Marking of carbon steel wheels hub stamping
Paragraph 17.1

AAR Manual of Standards and Recommended Practices Wheels and Axles

M-107/M-208

APPENDIX B

Manufacturer's Identification	Manufacturer	Location	Cast or Wrought	No Longer in Production
AW	Scaw Metals	Germiston, South Africa	C	
C	Abex Rail **	Calera, Alabama	C	X
CO	Datong ABC Castings Company LTD	Datong, Shanxi Province, China	C	
CZ	Amsted Maxion (Formerly lochpe-maxion S.A.)	Cruzeiro, Brazil	C	
FM	FM Fundiciones de Hierro y Acero	Mexico	C	X
GB	Griffin Wheel Company	Bensenville, Illinois	C	X
GC	Griffin Wheel Company	Columbus, Ohio	C	
GI	Griffin Wheel Company	Kansas City, Kansas	C	
GK	Griffin Wheel Company	Keokuk, Iowa	C	
GL	Griffin Wheel Company	Colton, CA	C	X
GS	Griffin Wheel Company	Bessimer, Alabama	C	
GT	Griffin Wheel Company	Winnipeg, Canada	C	
GY	Griffin Wheel Company	St. Hyacinthe, Canada	C	X
RZ	Tianrui Group Foundry Co. Ltd	Ruzhou, Henan Province, PRC	C	
S	Abex **	St. Louis, Missouri	C	X
SJ	Abex	Johnstown, Pennsylvania	C	X
SO	ABC Rail (formerly Abex)	Calera, Alabama	C	X
T	Abex **	Toledo, Ohio	C	X
TA	Tonghe Wheel Company	Xinyang City, Henan Province, PRC	C	
WI	Rail Wheel Factory (Formerly Wheel and Axle Plant)	Yelahanka, Bagalore, India	C	
A	Armco		W	X
BV	B.V.V. (Formerly VSG)	Bochum, Germany	W	
BW	Bethlehem		W	X
CS	Comsteel	Waratah NSW, Australia	W	
CW	U.S. Steel	Pittsburg, Pennsylvania	W	X
DW	Bonatrans a.s. (Formerly ZDB)	Bohumin, Czech Republic	W	
EV	Evrax Group	Nizhni Tagil, Russia	W	
EW	Edgewater Steel LTD	Oakmont, Pennsylvania	W	X
FW	Creusot-Loire	France	W	X
G	U.S. Steel	Gary, Indiana	W	X
HW	Maanshan Iron and Steel Co. LTD	Anhui, Province, P.R.C.	W	
JW	Sumitomo Metal Industries LTD	Osaka, Japan	W	
KW	Klockner	Germany	W	X
LW	Lucchini Sidermeccanica SpA (Formerly Gruppo Lucchini)	Loveve, Italy	W	
MW	MWL (Formerly Mafersa)	Cacapavz, Sao Paulo, Brazil	W	
NW	Niznedneprovssky Tube Rolling Plant (NTRP)	Dnepropetrovsk, Ukraine	W	
P	British Steel	UK	W	X
QW	Construcciones y Auxiliar de Ferrocarriles (CAF)	Beasain, Spain	W	
RW	S. C. SMR S.A (Formerly SMR/MECANO)	Bals, Romania	W	
SW	Standard Steel LLC	Burnham, Pennsylvania	W	
TW	Adtranz	UK	W	X
TY or TZ (TY not used after 10/ 06)	Taiyuan Heavy Industry CO., LTD	Taiyuan, Shanxi Province, PRC	W	
VK	Vyksa Steel Works	Nizhegorodsky Region, Russia	W	
VW	Valdunes	Dunkerque & Valenciennes, France	W	
ZW	Canadian Steel Wheel	Canada	W	X

** The letters C, S, or T directly precede the wheel serial number for wheels manufactured prior to about April 1978

Fig. B.6 AAR-approved manufacturers

IMPLEMENTED 08/2012

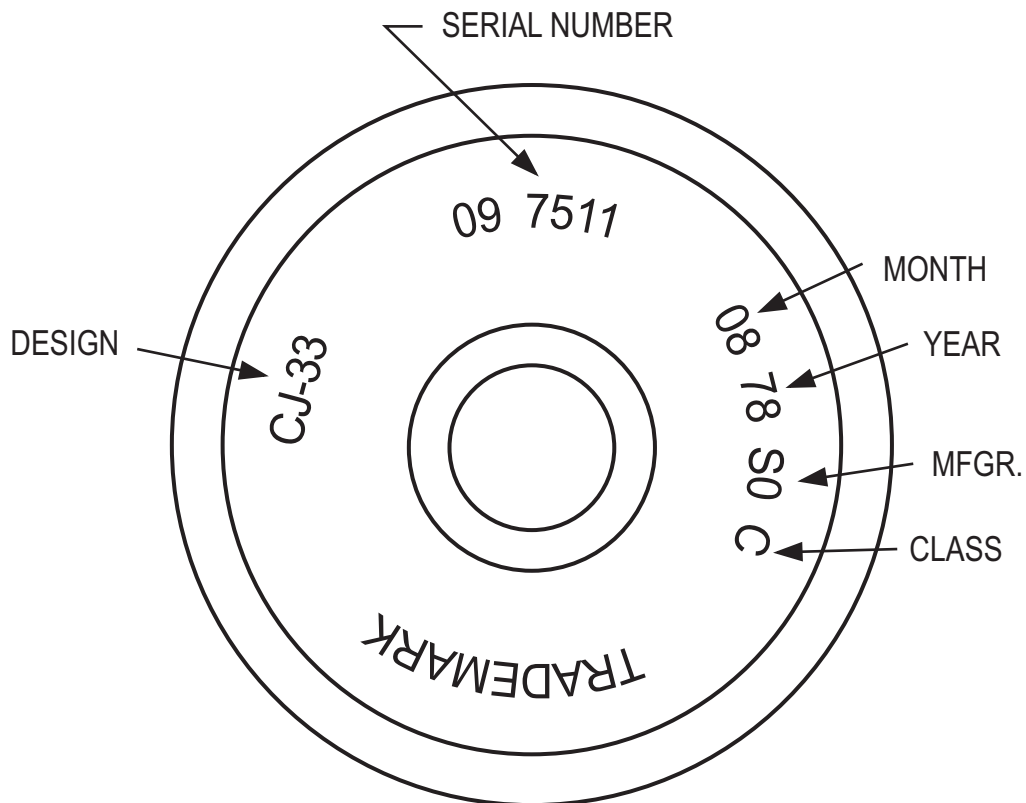

- Note 1.** Characters to be cast on the back plate of wheels shall, at least, show the manufacturer's serial number, date of manufacture, manufacturer's identification, class, and design designation.
- Note 2.** Cast markings shall be legible characters, at least 1 in. high and so spaced to allow related characters to be readily distinguished as a group.
- Note 3.** All wheels shall be marked for class using letters L, A, B, C, or D, as appropriate.
- Note 4.** The three groups (1) design; (2) serial number; and (3) date of manufacture, manufacturer, and class must be clearly separate.

Fig. B.7 Raised markings on cast carbon steel wheels
Paragraph 17.1

**AAR Manual of Standards and Recommended Practices
Wheels and Axles**

M-107/M-208

APPENDIX B

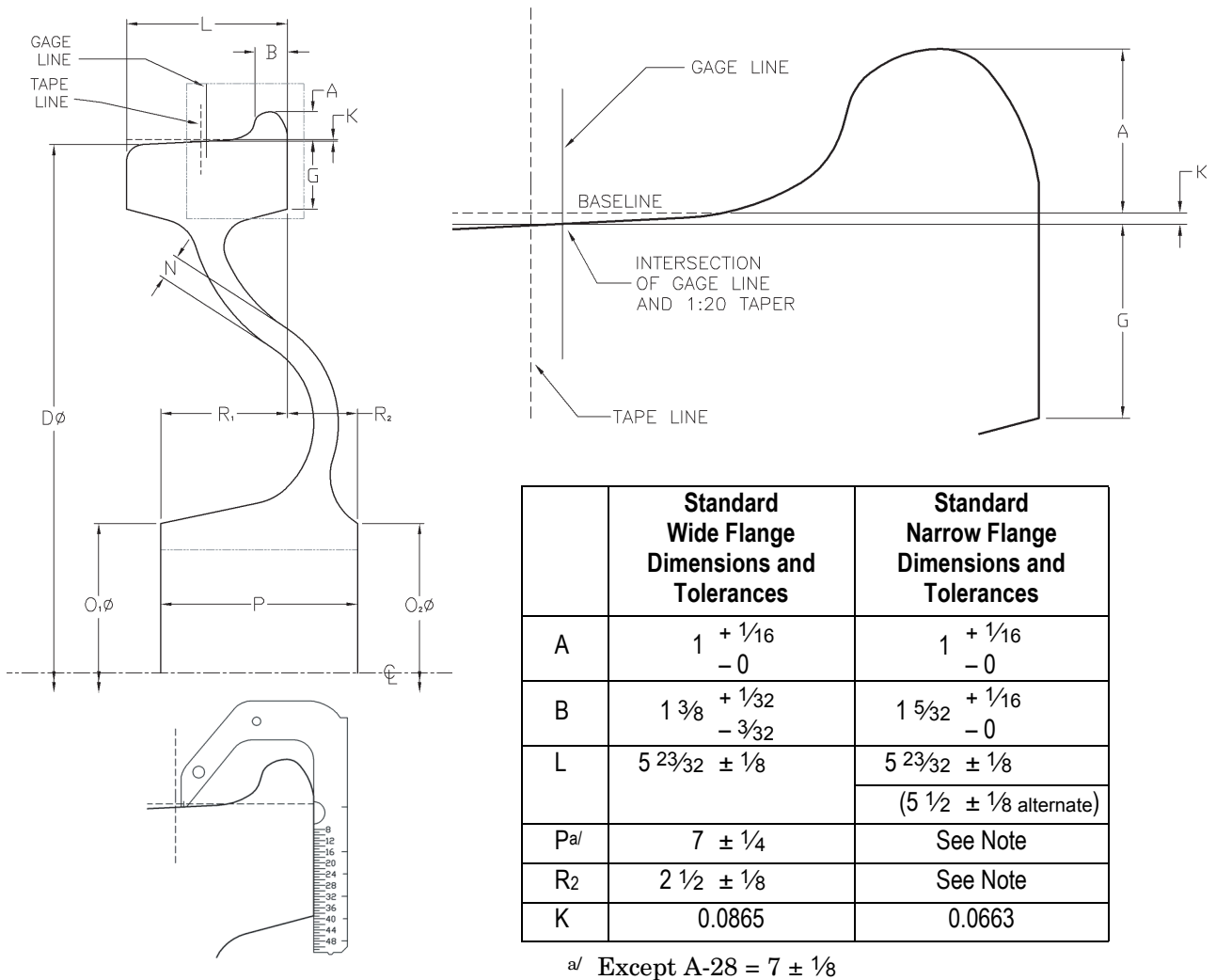

**Fig. B.8 Standard dimensions and tolerances and permissible variations
Paragraphs 2.1 and 15.1**

Note: For standard wheel types and for dimensions and other data not shown above, see Figs. B.9 through B.14.

9.0 PERMISSIBLE VARIATIONS IN DIMENSIONS NOT SHOWN BY TOLERANCES ON FIGS. B.9 THROUGH B.14

9.1 Inside Diameter—Front Face of Rim

The inside diameter of the rim at the front face of the wheel shall not differ from that at the back face of the wheel by more than 1/4 in.

9.2 Thickness of Rim

In any wheel, the radial thickness of the rim shall not vary more than 1/8 in. around the wheel.

9.3 Corner at Inside Diameter of Back Face

A sharp corner is preferable to facilitate measurement. In any case, the radius of the corner shall not exceed 1/8 in.

9.4 Plane of Back Face

When wheels are gauged with a straight edge applied to the back face of the rim, no point on the back face of narrow-flange wheels more than 1 1/4 in. from the inside edge of the rim shall be more than 1/32 in. from the straight edge. For wide-flange wheels, no point on the back face of the rim shall be more than 1/32 in. from the straight edge. For narrow- and wide-flange wheels, the back face of the rim measured on the circumference at a distance 1 1/4 in. inward from the apex of the flange must be in plane within 0.040 in. Total Indicator Reading (TIR) with respect to the plane of the front face of the rim.

9.5 Hub Wall Thickness

The thickness of the hub wall in any one wheel measured at any two points equidistant from the face of the hub shall not vary by more than 3/8 in. if the hub is not machined, nor by more than 1/8 in. if the hub is machined.

9.6 Rotundity

Tread when gauged with a ring gauge must not have an opening between tread and gauge at any point over .022 in.

9.7 Diameter of Bore

The diameter of rough bore shall not vary more than 1/16 in. over nor more than 1/16 in. under the dimensions specified by the purchaser.

9.8 Eccentricity of Bore

Eccentricity between the rough bore and tread, measured in the plane of the taping line, shall not exceed .0625 in. TIR, except that no more than 5% of wheels delivered may be over .0625 in. TIR and these must not exceed .09375 in. TIR.

**AAR Manual of Standards and Recommended Practices
Wheels and Axles**

M-107/M-208

APPENDIX B

IMPLEMENTED 05/2012

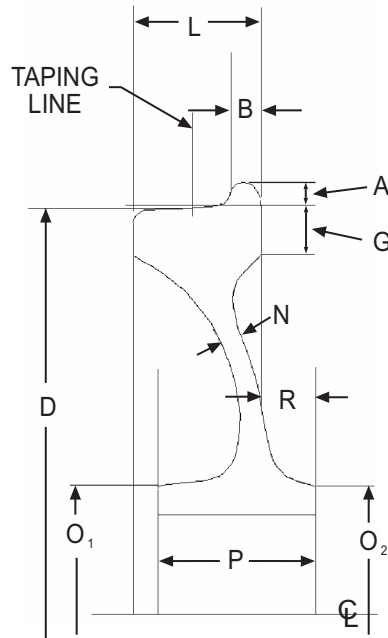

STANDARD AAR WHEEL TYPES—WIDE-FLANGE CONTOUR—FOR FREIGHT CAR SERVICE—CARBON STEEL												
AAR TYPE	A-28 CA-28	E-28 CE-28	A-30 CA-30	J-33 CJ-33	M-33 CM-33	P-33 CP-33	H-36 CH-36	J-36 CJ-36	K-36 CK-36	B-38 CB-38	C-38 CC-38	D-38 CD-38
STATUS DATE	STND 1952	STND 1985	STND 1946	STND 1956	STND 1961	STND 1984	STND 1962	STND 1962	STND 1962	STND 1964	STND 1964	
EFFECTIVE DATE	1971	7/1/85	1971	1968	1968	3/1/85	10/1/72	1968	1968	9/1/73	1968	
TREAD TYPE	M-W	1-W	M-W	1-W	2-W	M-W	1-W	2-W	M-W	1-W	2-W	M-W
INTENDED AXLE CLASS	F, K	E	F, K	D, E	D, E	D, E, F, G	F, K	F, K	F, K	G	G	G
MAX. CAP. PER WHEEL (LB)	32,875	24,375	32,875	27,500	27,500	32,875	35,750	35,750	35,750	39,375	39,375	39,375

DIMENSION AND TOLERANCES—ALL ENTRIES IN INCHES, EXCEPT TAPES												
D	28 + 14 TAPES (5%–5)	28 + 14 TAPES (5%–5)	30 + 14 TAPES (5%–5)	33 + 14 TAPES (5%–5)	33 + 14 TAPES (5%–5)	33 + 14 TAPES (5%–5)	36 + 14 TAPES (5%–5)	36 + 14 TAPES (5%–5)	36 + 14 TAPES (5%–5)	38 + 14 TAPES (5%–5)	38 + 14 TAPES (5%–5)	38 + 14 TAPES (5%–5)
G (MIN)	2 1/2	1 1/2	2 1/2	1 1/4	2	2 1/2	1 1/2	2	2 1/2	1 1/2	2	2 1/2
N (MIN)	3/4	5/8	3/4	5/8	5/8	3/4	3/4	3/4	3/4	7/8	7/8	7/8
O ₁	+1 11 1/8–0	+1 10 5/8–0	+1 11 1/8–0	+1 10 5/8–0	+1 10 5/8–0	+1 11 7/8–0	+1 11 1/8–0	+1 11 1/8–0	+1 11 1/8–0	+1 12 1/8–0	+1 12 1/8–0	+1 12 1/8–0
O ₂	+1 11 1/8–0	+1 10 5/8–0	+1 11 1/8–0	+1 10 5/8–0	+1 10 5/8–0	+1 11 7/8–0	+1 11 1/8–0	+1 11 1/8–0	+1 11 1/8–0	+1 12 1/8–0	+1 12 1/8–0	+1 12 1/8–0
MAX FINISH BORE	8 7/8	8 3/8	8 7/8	8 3/8	8 3/8	9 5/8	8 7/8	8 7/8	8 7/8	9 5/8	9 5/8	9 5/8
MIN HUB WALL	1 1/8	1 1/8	1 1/8	1 1/8	1 1/8	1 1/8	1 1/8	1 1/8	1 1/8	1 1/4	1 1/4	1 1/4
P ₁	7 ± 1/8	7 ± 1/4	7 ± 1/4	7 ± 1/4	7 ± 1/4	7 ± 1/4	7 ± 1/4	7 ± 1/4	7 ± 1/4	7 ± 1/4	7 ± 1/4	7 ± 1/4
R	2 1/2 ± 1/8	2 1/2 ± 1/8	2 1/2 ± 1/8	2 1/2 ± 1/8	2 1/2 ± 1/8	2 1/2 ± 1/8	2 1/2 ± 1/8	2 1/2 ± 1/8	2 1/2 ± 1/8	2 1/2 ± 1/8	2 1/2 ± 1/8	2 1/2 ± 1/8

NOTES:

- HUB LENGTH TOLERANCE IS BASED ON FINISHED DIMENSION.
- 5 1/2 × 10 AXLE ALSO STANDARD FOR J-33 AND M-33; 5 1/2 × 10, 6 × 11, AND 6 1/2 × 12 AXLES ALSO STANDARD FOR P-33

**Fig. B.9 Standard AAR wheel types—wide-flange contour—for freight car service
Paragraphs 2.1, 15.1, and 15.2**

AAR Manual of Standards and Recommended Practices

Wheels and Axles

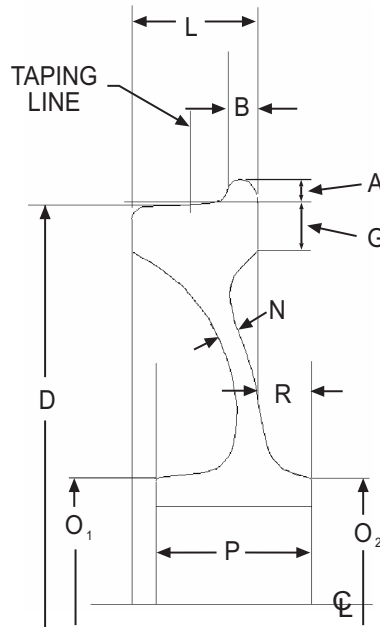

STANDARD AAR WHEEL TYPES—NARROW-FLANGE CONTOUR—FOR DIESEL LOCOMOTIVE									
AAR TYPE	F-36 CF-36	A-38 CA-38	E-40 CE-40	A-41 CA-41	A-42 CA-42	A-43 CA-43	C-42 CC-42	D-42 CD-42	E-42 CE-42
STATUS DATE	STND 1946	STND 1947	STND 1982	STND 1997	STND 1946	STND 1997	STND 1946	STND 1997	STND 1997
EFFECTIVE DATE	8/1/46	1947	3/1/83	1997	8/1/46	1997	1947	1997	1997
TREAD TYPE	M-W	M-W	M-W*	M-W*	M-W*	M-W*	M-W*	M-W	M-W

DIMENSION AND TOLERANCES—ALL ENTRIES IN INCHES, EXCEPT TAPES, SEE Fig. B.8 FOR DIMENSIONS A, B, C, and L FOR ALL NARROW-FLANGE WHEEL TYPES									
D	36" TAPES + 14 0	38" TAPES + 14 0	40" TAPES + 14 0	41" TAPES + 14 0	42" TAPES + 14 0	43" TAPES + 14 0	42" TAPES + 14 0	42" TAPES + 14 -0	42" TAPES + 14 -0
G (MIN)	2½	2½	2½	3	3	3	2½	2½	3½
N (MIN)	¾	7/8	1	1	1	1	1	1	1
O ₁	+1 13-0	+1 10¾-0	12½±1/8	12½±1/8	+1 11½-0	12½±1/8	+1 13½-0	12½±1/8	12½±1/8
O ₂	+1 13-0	+1 10¾-0	13¼±1/8	13¼±1/8	+1 11½-0	13¼±1/8	+1 13½-0	13¼±1/8	13¼±1/8
P	6½±1/8	7±1/8	6½±1/8	6½±1/8	7±1/8	6½±1/8	6½±1/8	6½±1/8	6½±1/8
R ₁	4 ¹³ / ₁₆ ±1/8	5 ⁵ / ₁₆ ±1/8	4 ¹³ / ₁₆ ±1/8	4 ¹³ / ₁₆ ±1/8	4 ⁵ / ₁₆ ±1/8	4 ¹³ / ₁₆ ±1/8	4 ¹³ / ₁₆ +1/8	4 ¹³ / ₁₆ ±1/8	4 ¹³ / ₁₆ ±1/8
R ₂	1 ¹¹ / ₁₆ f	1 ¹¹ / ₁₆ f	1 ¹¹ / ₁₆ f	1 ¹¹ / ₁₆ f	2 ¹¹ / ₁₆ ±1/8	1 ¹¹ / ₁₆ f	1 ¹¹ / ₁₆ f	1 ¹¹ / ₁₆ f	1 ¹¹ / ₁₆ f
MAX FINISH BORE	10¼	8½	9 ¹⁵ / ₁₆	9 ¹⁵ / ₁₆	9¼	9 ¹⁵ / ₁₆	10¾	9 ¹⁵ / ₁₆	9 ¹⁵ / ₁₆
MIN HUB WALL	1¾	1½	** 1½	1½	1½	1½	1¾	1½	1½

NOTES:

1. WHERE DIMENSION R2 IS MARKED F, EXTRA STOCK OF 1/16 IN. TO 3/16 IN. OVER SPECIFIED DIMENSION MAY BE LEFT FOR MACHINING OF EACH FINISHED SURFACE OR WHEEL MAY BE FURNISHED FINISHED TO EXACT DIMENSION SHOWN. HUB LENGTH TOLERANCE IS BASED ON FINISHED DIMENSION.

* REFERENCE GROOVE REQUIRED—SEE RP-619

** HUB WALL THICKNESS MAY BE REDUCED AS NECESSARY FOR APPLICATION OF ROLLER BEARING WATER GUARD.

Fig. B.10 Standard wheel types for locomotive service
Paragraphs 2.1, 15.1, and 15.2

AAR Manual of Standards and Recommended Practices

Wheels and Axles

M-107/M-208

APPENDIX B

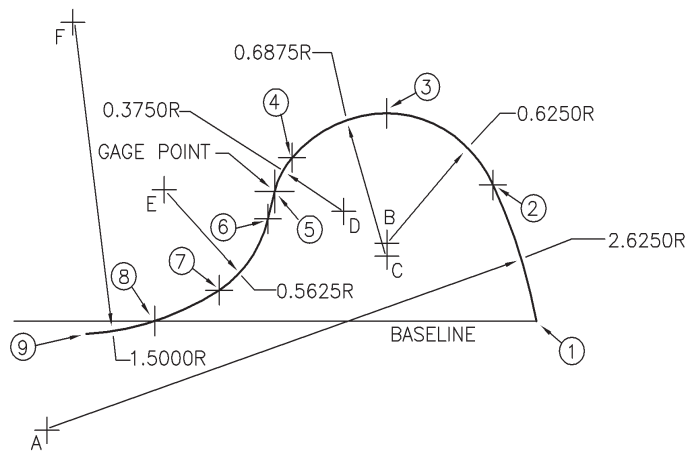
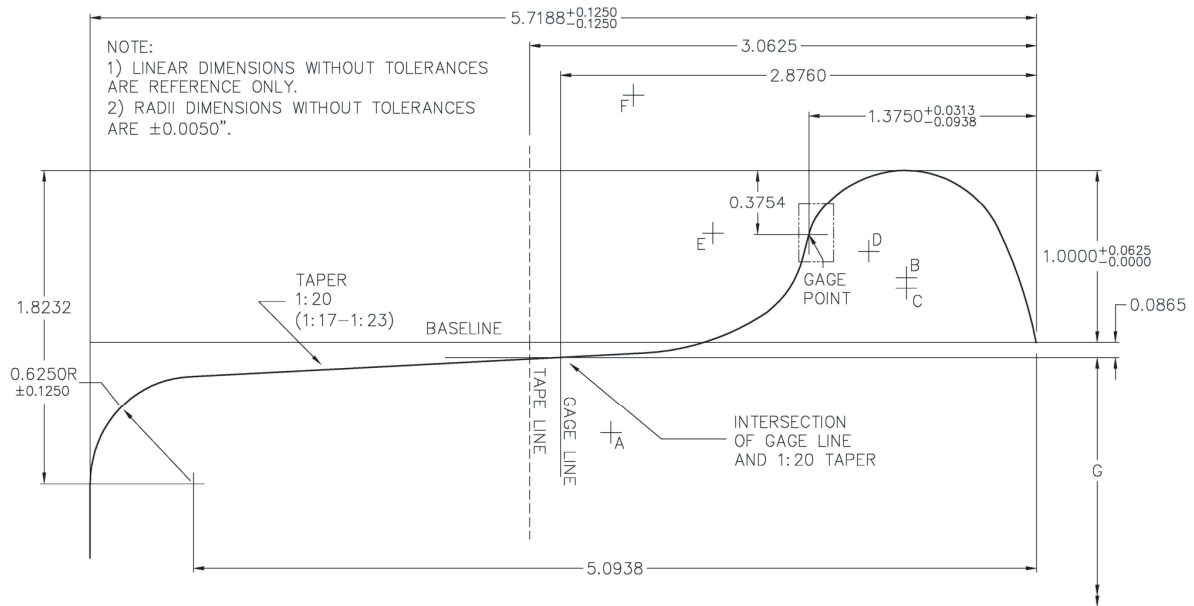

AAR-1B WIDE PROFILE CENTERS OF RADII RELATIVE TO GAUGE POINT

POINT	X	Y
A	-1.196896	-1.149921
B	0.589000	-0.249600
C	0.589000	-0.312100
D	0.362211	-0.097100
E	-0.580300	0.007500
F	-1.060300	0.812800

AAR-1B WIDE PROFILE INTERSECTION OF POINTS RELATIVE TO GAUGE POINT

POINT	X	Y
1	1.375000	-0.624585
2	1.147435	0.031070
3	0.589000	0.375400
4	0.091706	0.162616
5	0.000000	0.000000
6	-0.035442	-0.132273
7	-0.291159	-0.474998
8	-0.631437	-0.624585
9	-0.989517	-0.685529

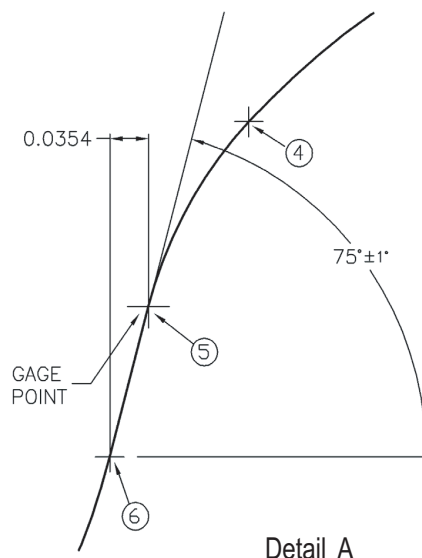
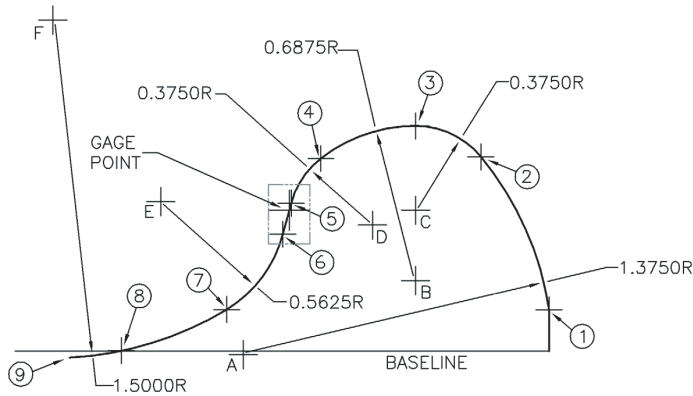
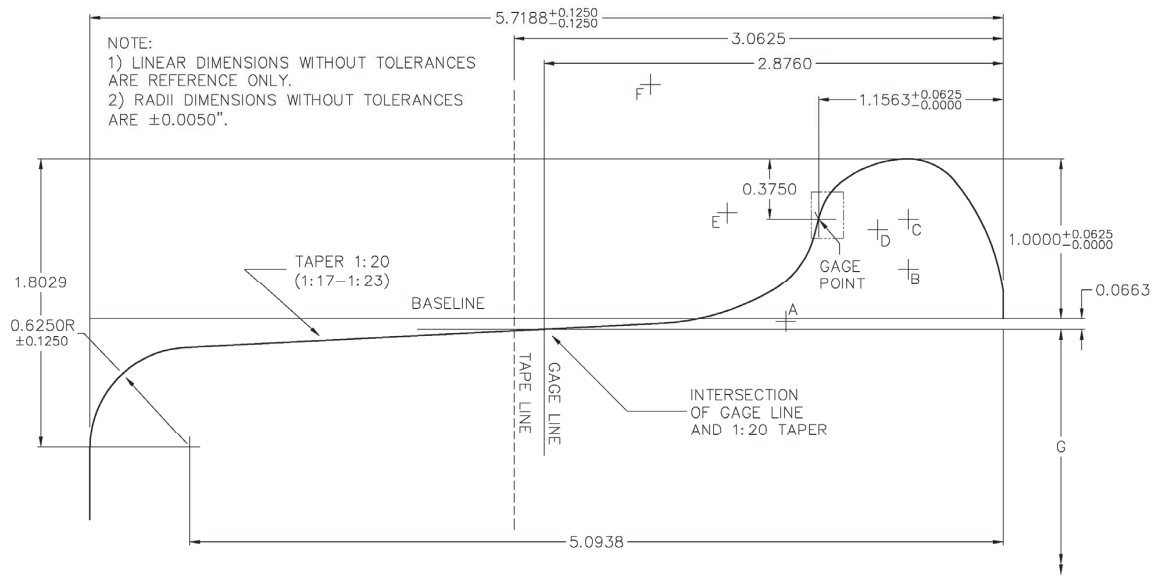

Fig. B.11 AAR-1B wide-flange contour for freight car wheels
 Paragraphs 2.1, 15.1, and 16.2

AAR Manual of Standards and Recommended Practices

Wheels and Axles



AAR-1B NARROW PROFILE CENTERS OF RADII RELATIVE TO GAUGE POINT

POINT	X	Y
A	-0.204400	-0.641800
B	0.562500	-0.312500
C	0.562500	0.000000
D	0.370581	-0.065876
E	-0.571971	0.038692
F	-1.052000	0.844000

AAR-1B NARROW PROFILE INTERSECTION OF POINTS RELATIVE TO GAUGE POINT

POINT	X	Y
1	1.156300	-444011
2	0.853075	0.237046
3	0.562500	0.375000
4	0.140565	0.230296
5	0.008400	0.031335
6	-0.028575	-0.106659
7	-0.278542	-0.441210
8	-0.748621	-0.625000
9	-0.977100	-0.654129

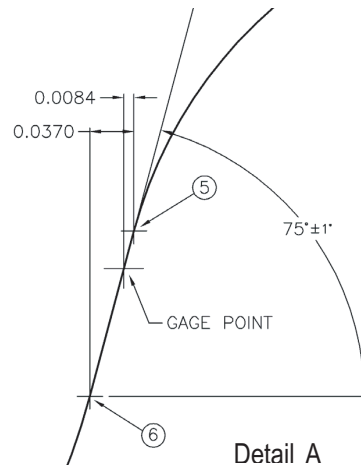
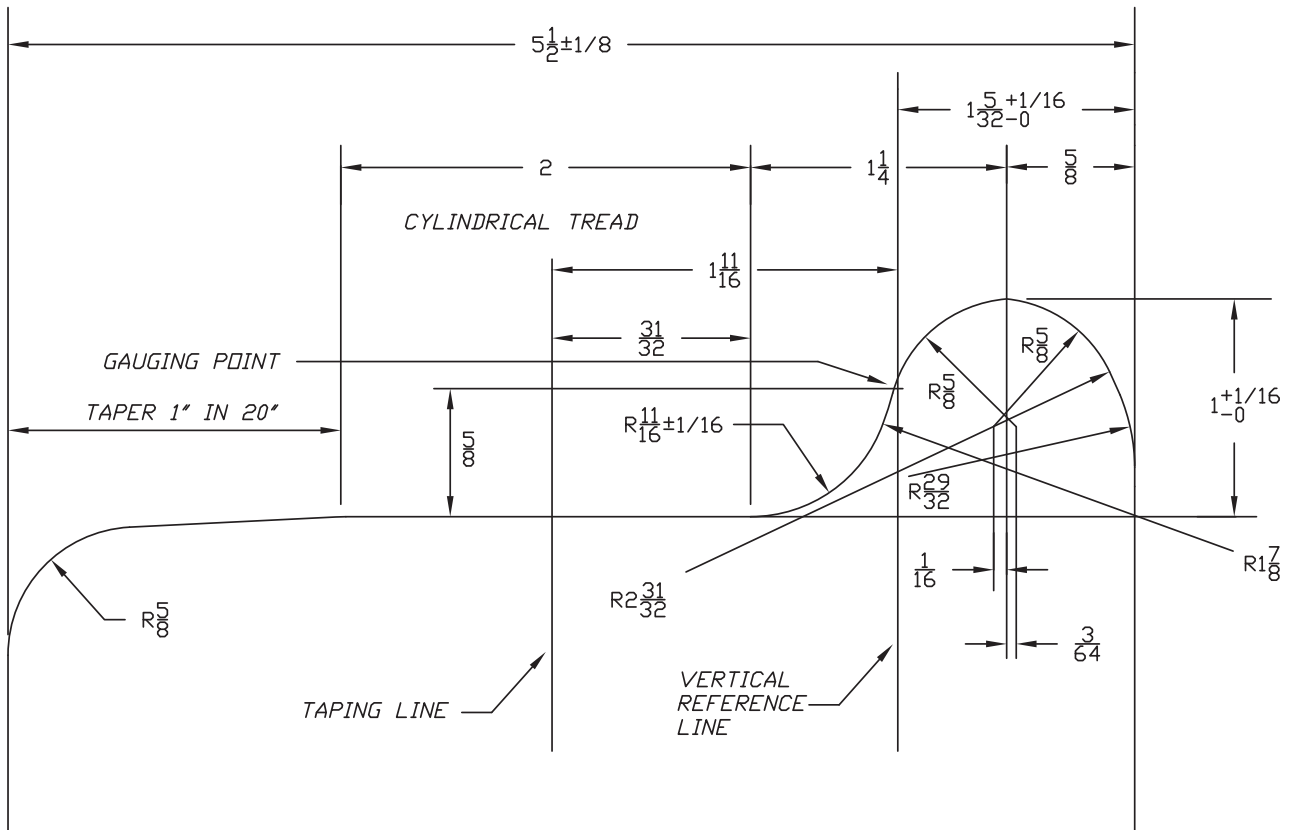

Fig. B.12 AAR-1B narrow-flange contour for freight car wheels
 Paragraphs 2.1, 15.1, and 16.2

AAR Manual of Standards and Recommended Practices
Wheels and Axles

M-107/M-208

APPENDIX B



NOTE: WHEN WHEEL RIMS ARE REDUCED IN THICKNESS TO SUCH AN EXTENT THAT LATHE DOGS INTERFERE WITH THE 5/8-IN. RADIUS AT THE OUTER RIM FACE, THIS RADIUS MAY BE REDUCED AS NECESSARY OR A CHAMFER USED. FREIGHT LOCOMOTIVE WHEEL RIMS SHALL BE MACHINED WITH A MAXIMUM RADIUS OF 5/8 IN. ON THE OUTER RIM FACE. A CHAMFER IS ALLOWED TO EXTEND PAST THE RADIUS AT 45°, BUT MUST BE NO LONGER THAN 0.4375 IN. MEASURED ALONG ITS LENGTH.

Fig. B.13 Cylindrical tread contour for narrow-flange wheels
Paragraphs 2.1 and 16.2

**AAR Manual of Standards and Recommended Practices
Wheels and Axles**

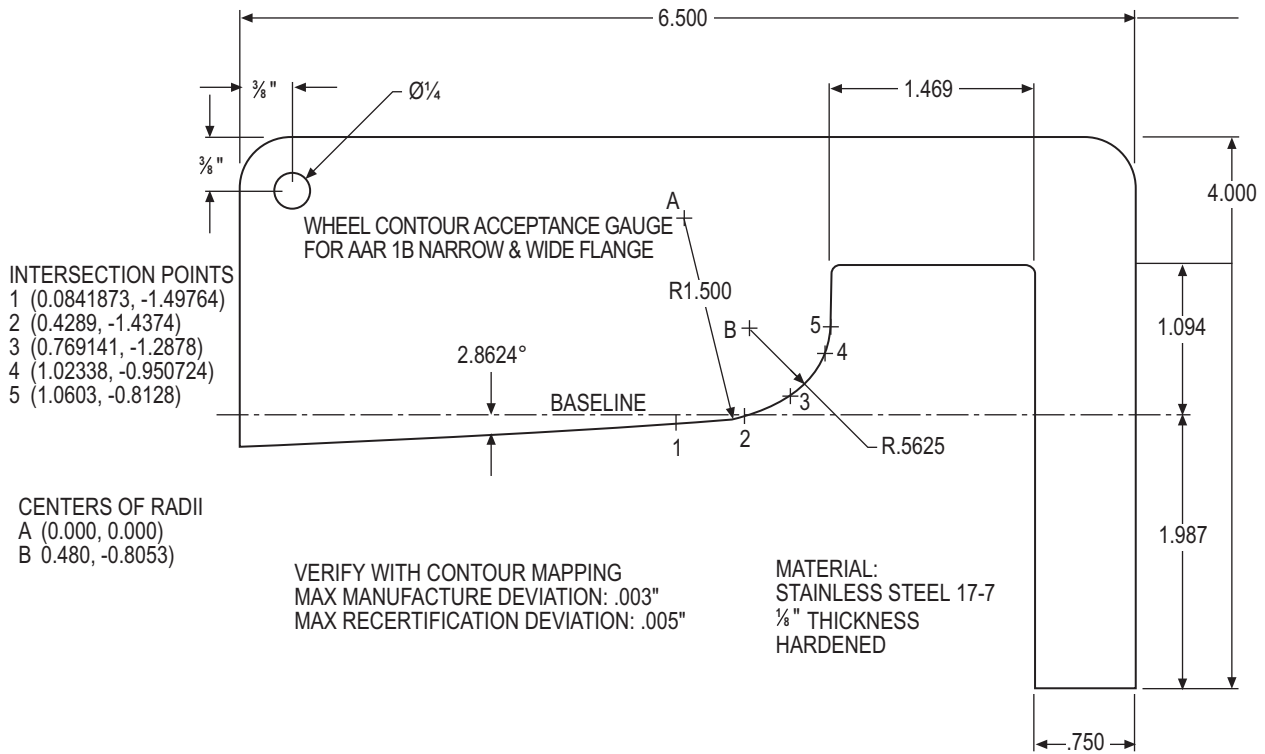

**Fig. B.14 Tread contour gauge for AAR-1B wheels
Paragraph 16.5**

**APPENDIX C
AUTHORIZATION FOR CLASS D WHEEL TEST ALLOTMENT**

1.0 Each manufacturer must obtain an authorization for Class D test wheels from the Committee prior to delivery. All requirements of the M-107/M-208 wheel specification and associated appendixes apply to Class D wheels.

1.1 The intent of Class D is to provide wheel materials with superior resistance to tread damage when compared to Class C wheels, without compromising any other safety performance characteristics.

2.0 Class D wheel applicants must submit results from laboratory material tests as described in paragraph 3.0 of this appendix, "Material Testing." Upon acceptance of the laboratory test results, the WABL Committee will authorize a test allotment of 5,000 wheels for field service testing in interchange service.

3.0 MATERIAL TESTING

3.1 The following material testing is required. The applicant must contact the WABL Committee to schedule an AAR observer. Three sample wheels must be tested. Unless otherwise approved by WABL, an AAR observer is required. All costs for the tests and the observer are to be paid by the applicant. Wheel materials should meet the minimum properties listed in Table 3.1.

3.1.1 Tension testing shall be conducted on two specimens at ambient temperature and two specimens at 1,000 °F. Specimens shall be taken from as close to the tread as possible (at least 1/8 in. of the original wheel tread must remain visible at the ends of the test specimen) in the circumferential direction. Ultimate tensile strength, 0.2% offset yield strength, percentage elongation, and percentage reduction of area shall be determined. Tests must be conducted per ASTM E21 (1,000 °F) and ASTM A370 (ambient temperature), latest edition.

3.1.2 The microstructure shall be classified in the report and should be free of martensite. Six microstructural specimens (1/2 in.² section) shall be taken in the radial plane direction adjacent to the microcleanliness specimens and must include the tread surface. The intent is to classify all microstructures in the specimen, to include the tread surface. The report should contain sufficient photographic evidence to support the conclusions.

3.1.3 Absence of tensile hoop stress shall be documented by a radial saw cut made to a depth at least 1 in. deeper than the rim inner diameter. No opening of the cut shall be present at the conclusion of the cut.

3.1.4 Hardness mapping of the test wheels shall be performed per M-107/M-208, Section 11.5. In addition, Brinell hardness measurements shall also be taken along the centerline of the plate to the hub inner diameter at approximately 1/2 in. spacing and reported for reference only.

3.1.5 Fracture toughness type testing shall be determined for two samples per test wheel at 70 °F to 75 °F according to ASTM E 399, latest edition. The sample shall be taken as shown in Fig. 3.1. If a valid K_{Ic} is not obtained, then report the K_Q value.

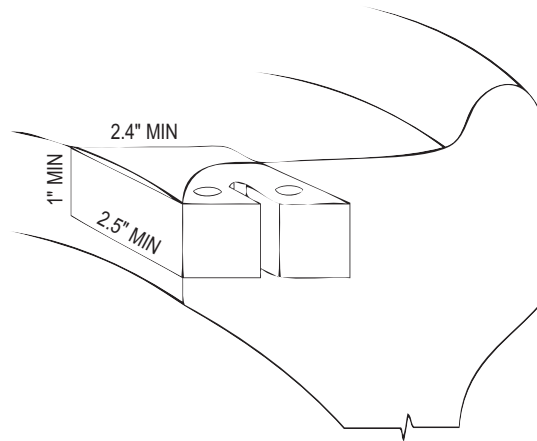

Fig. 3.1 Fracture toughness test sample

3.1.6 The manufacturer must provide lab data demonstrating the relative wear and shelling performance as compared to Class C. The manufacturer must specify the test methods used for the comparison. The following test conditions are recommended. Testing protocols may be changed if better methods can be demonstrated.

3.1.6.1 To demonstrate performance no worse than Class C, comparative accelerated rolling load wear tests shall be conducted. Tests shall be performed using two discs constructed of the proposed wheel material.

3.1.6.1.1 Test conditions shall be as follows:

- Contact pressure = 319,500 psi
- 0.75% slip
- Duration = 500,000 cycles

3.1.6.1.2 The result must be calculated wear rates for Classes C and D.

3.1.6.2 To demonstrate performance superior to Class C, an accelerated rolling load shelling test shall be conducted using two discs.

3.1.6.2.1 Test conditions shall be as follows:

- Contact pressure = 159,750
- 0.3% slip
- Duration = onset of shelling as determined using a vibration sensor

3.1.6.2.2 The result must compare cycles to shelling onset for Classes C and D.

Table 3.1 Minimum material properties

	Ambient (65 °F–80 °F)	1,000 °F
Hardness	341 HB–415 HB	NA
UTS (psi)	>157,000	>70,000
Yield (psi) (0.2% offset method)	>110,000	>50,000
% Elongation in 2 in.	>14	>20
Reduction of Area (%)	>15	>40
Fracture toughness (K_{Ic} or K_Q)	>35 ksi sq root in.	

4.0 FIELD SERVICE TEST ALLOTMENT

4.1 Upon Committee review of the laboratory test program, an allotment of 5,000 wheels shall be granted. The manufacturer shall inspect all wheels in service and report to the Committee the cause for any removals. Manufacturer shall select a service that is expected to accumulate at least 50,000 miles per year.

5.0 FIELD SERVICE TESTING

5.1 It is the responsibility of the manufacturer to monitor the performance of the test wheels in service and report results to the WABL Committee. Reduction of removals for tread damage (as compared to Class C) must be demonstrated. The field service test shall include the following:

- Monitoring a minimum of 1,000 wheels in 286k service
- Documenting car numbers and location of all test wheels
- 100% tracking—for removal causes
- Visual inspections and sample wear monitoring (30% of test wheels) at the following intervals:
 - At least 25,000 miles
 - At least 50,000 miles
 - At least 100,000 miles
 - At least 300,000 miles
 - 400,000 miles

5.2 The field service report shall include the following:

- Removal causes
- Reduction of tread defect removals compared to Class C in the same service
- Percentage of test wheels remaining in service after 300,000 miles

6.0 ADDITIONAL ALLOTMENTS

6.1 A second test allotment of 5,000 wheels may be applied for after the 300,000-mile report.

6.2 After the 400,000-mile test report is accepted by the WABL Committee, additional allotments may be approved per Appendix A.

**AAR Manual of Standards and Recommended Practices
Wheels and Axles**

THIS PAGE LEFT BLANK INTENTIONALLY

Brookville Equipment Corporation

BROOKVILLE
175 Evans Street PO Box 130
Brookville, Pa 15825
Phone (814) 849-2000 Fax (814) 849-2010

Our Quotation # 250408-00
02/27/2025

To :
REGIONAL TRANSIT AUTHORITY
PROCUREMENT DEPT.
3901 DESIRE PARKWAY
NEW ORLEANS LA 70126

Quotation Valid Thru : 03/27/2025
Terms : NET 30

We are pleased to quote your requirements as shown below. Our company has a reputation for delivering quality products on time and we look forward to the opportunity of serving you.

Item	Facility / Part / Rev / Description / Details	Quantity Quoted	Unit Price	Extended Price
001	Default RESILIENT WHEEL, 28" 28" resilient wheel Delivery: 44 weeks Rev NS U/M EA	40.00	18,080.3000	\$ 723,212.00

Total Items Price \$ 723,212.00

Brookville Equipment Corporation Sales Order Standard Terms and Conditions are an integral part of this order. They are included herein by reference and are available at <https://www.brookvillecorp.com/resources/sales-terms/>

Quotes are valid for 15 days upon the date submitted unless otherwise noted in the expiration date. If placing this order, please mention the quote number within your purchase order.

Thanks again for your interest in our company as one of your suppliers.



Board Report and Staff Summary

File #: 25-024

Finance Committee

Outside Counsel Legal Services

DESCRIPTION: Outside Counsel Legal Services	AGENDA NO: Click or tap here to enter text.
ACTION REQUEST: <input checked="" type="checkbox"/> Approval <input type="checkbox"/> Review Comment <input type="checkbox"/> Information Only <input type="checkbox"/> Other	

RECOMMENDATION:

Authorize the Chief Executive Officer to: (1) extend contracts with current outside counsel firms for a one-year term to allow for continuity of services for an amount not to exceed \$530,000. (2) award professional legal services contracts for a term of three years, with a two-year option to renew with competitively selected firms for an amount not to exceed \$1,000,000 for the first year. The total amount to be allocated is \$1,530,000.

ISSUE/BACKGROUND:

The RTA is in need of qualified law firms to provide outside counsel legal services on an as-needed basis in various categories/specialties.

DISCUSSION:

In 2007, the Board of Commissioners authorized the following firms to perform outside legal services for the RTA.

- Wilkerson & Henry, LLC
- Bordenave Boykin & Ehret
- Gauthier, Houghtaling & Williams, LLP
- Keifer & Keifer
- Shorty, Dooley and Hall, LLC
- The Broussard Baloney Law Firm, APC
- Mitchell & Associates
- The Willard Firm

Four of the eight selected firms are currently handling active litigation matters:

- Bordenave Boykin & Ehret (currently operating as Boykin, Utley)
- Keifer & Keifer

Shorty, Dooley and Hall, LLC (currently operating as the Law Office of Michael J. Hall)

The Broussard Baloney Law Firm, APC

To allow for continuity of services, staff recommend retaining assigned counsel for pending matters for an additional one-year term.

The RTA recently issued a solicitation seeking qualified and experienced law firms to represent the RTA, as needed in each of the following categories:

Category 1: General Litigation

Premises Liability

Appellate

Category 2: Employment and Labor Law

Ethics

Category 3: Professional and Non-Professional Services

Category 4: Public Bid Law and Bid Protest/Litigation

Construction

DBE matters

Category 5: Municipal Bonds

Tax

Public Finance

Bankruptcy and Creditor/Debtor Rights

Category 6: Unique/Miscellaneous Transit Related Matters

There were five responsive firms:

Boykin, Utley

Butler Law Firm

Butler Snow, LLC

Kiefer & Kiefer

Wright Gray Harris, LLC

All responsive firms have been selected to provide services on a rotating basis in various categories.

Firm	Category 1	Category 2	Category 3	Category 4	Category 5	Category 6
Boykin, Utley	X	X	X			X
Butler Law Firm	X	X	X	X		
Butler Snow, LLC					X	
Kiefer & Kiefer	X	X	X			
Wright Gray Harris, LLC	X					

FINANCIAL IMPACT:

Funding totaling \$1,530,000 (one million, five hundred thirty thousand and 00/100) is currently available through the operating budget, account code 01-8800-02-7051-168-89-00-00000-00000-00000.

2025 Awards: (Year 1 allocation not to exceed \$1,000,000)

Boykin, Utley - \$270,000

Butler Law Firm - \$270,000

Butler Snow, LLC - \$10,000

Kiefer & Kiefer - \$250, 000

Wright Gray Harris, LLC - \$200,000

2007 Extensions: (Year 1 allocation not to exceed \$530,000)

Bordenave Boykin & Ehret (currently operating as Boykin, Utley) - \$250,000

Keifer & Keifer - \$250,000

Shorty, Dooley and Hall, LLC (currently operating as the Law Office of Michael J. Hall) - \$15,000

The Broussard Baloney Law Firm, APC - \$15,000

NEXT STEPS:

Proceed with the execution of professional services agreements as set forth above.

ATTACHMENTS:

1. Board Resolution
2. Administrative Review Form
3. Procurement Summary

Prepared By: Tracy L. Tyler
Title: Chief Legal Officer

Reviewed By: Gizelle Banks
Title: Chief Financial Officer



Lona Edwards Hankins
Chief Executive Officer

3/11/2025

Date



RESOLUTION NO. _____

FILE ID NO. _____

STATE OF LOUISIANA

PARISH OF ORLEANS

**AUTHORIZATION TO EXTEND CONTRACTS WITH CURRENT OUTSIDE COUNSEL
FIRMS AND (2) AUTHORIZATION TO AWARD CONTRACTS FOR OUTSIDE COUNSEL
LEGAL SERVICES**

Introduced by Commissioner _____, seconded
by Commissioner _____.

WHEREAS, the RTA issued a Request for Proposals (RFP) # 2024-033 for Outside Counsel Legal Services for an initial term of term of three (3) years, with a two-year option to renew;

WHEREAS, seven (7) proposals were received and five (5) proposals were deemed responsive;

WHEREAS, RTA staff evaluated all elements of the submittals in accordance with requirements prescribed by the RTA and applicable federal and state laws;

WHEREAS, the following firms were evaluated and recommended to provide outside counsel legal services on a rotating basis in select categories:

- Boykin, Utley
- Butler Law Firm
- Butler Snow, LLC
- Kiefer & Kiefer
- Wright Gray Harris, LLC

WHEREAS, in 2007, the following firms were approved by the Board of Commissioners to provide outside counsel legal services:

- Bordenave Boykin & Ehret (currently operating as Boykin, Utley)
- Keifer & Keifer



RESOLUTION NO. _____

PAGE TWO

Shorty, Dooley and Hall, LLC (currently operating as the Law Office of Michael J. Hall)

The Broussard Baloney Law Firm, APC

WHEREAS, to allow for continuity of services, the RTA desires to continue services with the previously engaged firms for an additional one-year term; and

WHEREAS, the funding is currently available through 01-8800-02-7051-168-89-00-00000-00000-00000.

NOW, THEREFORE, BE IT RESOLVED by the Board of Commissioners of the RTA that the Chairman of the Board, or his designee, is authorized to execute contracts with the following firms in the not to exceed amounts below totaling \$1,530,000 (one million, five hundred thirty thousand and 00/100):

2025 Awards:

Boykin, Utley - \$270,000

Butler Law Firm - \$270,000

Butler Snow, LLC - \$10,000

Kiefer & Kiefer - \$250, 000

Wright Gray Harris, LLC - \$200,000

2007 Extensions:

Bordenave Boykin & Ehret (currently operating as Boykin, Utley) - \$250,000

Keifer & Keifer - \$250,000

Shorty, Dooley and Hall, LLC (currently operating as the Law Office of Michael J. Hall) - \$15,000

The Broussard Baloney Law Firm, APC - \$15,000



Regional Transit Authority
2817 Canal Street
New Orleans, LA 70119-6301

504.827.8300

www.norta.com

RESOLUTION NO. _____

PAGE THREE

THE FOREGOING WAS READ IN FULL, THE ROLL WAS CALLED ON THE ADOPTION THEREOF AND RESULTED AS FOLLOWS:

YEAS: _____

NAYS: _____

ABSTAIN: _____

ABSENT: _____

AND THE RESOLUTION WAS ADOPTED ON THE _____ DAY OF MARCH 2025.

CHAIRMAN
BOARD OF COMMISSIONERS

**Regional Transit Authority
Administrative Review Form**

Project Name: Professional Legal Services

Type of Solicitation: RFP 2024-033

DBE/SBE Participation Goal: 0%

Number of Respondents: 7

Prime, Primary Contact and Phone Number	DBE and Non-DBE Subconsultants	DBE Commitment Percentage	Price (RFP and ITB ONLY)
Boykin, Utlely	N/A	0%	See Schedule 1 Price Sheet
Butler Law Firm	N/A	0%	See price enclosed
Butler Snow, LLC	N/A	0%	See Appendix B
Kiefer & Kiefer	N/A	0%	Atty. \$150 per hour Paralegals \$50 per hour
Wright Gray Harris, LLC	N/A	0%	See Fee Schedule
Transcendent Legal	N/A	0%	Non-Responsive
Sher Garner Cahill, Richter Klein & Hilbert	N/A	0%	Non-Responsive

*Indicates certified DBE or SLDBE firm that will contribute to the project's participation goal

Prime Firm Name	Required Items								
	LA Uniform Public Work Bid	Non Collusion	Debarment Prime	Debarment Lower	Restrictions on Lobbying	Buy America Compliance	Participant Info	Affidavit of Fee Disposition	Addenda
Boykin, Utlely	Y	Y	Y	Y	Y	Y	Y	Y	Y
Butler Law Firm	Y	Y	Y	Y	Y	Y	Y	Y	Y
Butler Snow, LLC	Y	Y	Y	Y	Y	Y	Y	Y	Y
Kiefer & Kiefer	Y	Y	Y	Y	Y	Y	Y	Y	Y
Wright Gray Harris, LLC	Y	Y	Y	Y	Y	Y	Y	Y	Y
Transcendent Legal	N/A	N/A	N/A	N/A	N/A	N/A	N/A	N/A	N/A
Sher Garner Cahill, Richter Klein & Hilbert	N/A	N/A	N/A	N/A	N/A	N/A	N/A	N/A	N/A

Review and verification of the above required forms, the below listed vendor is hereby found responsive to this procurement.

Vendor Name: We are going use all (5) vendors on a rotation basis

Certified by: Name and Title Shaun Temple, Contract Administrator

Procurement Personnel Only

Prime Firm Name	Bid Bond	Insurance	Responsiveness Determination	Responsible Determination					
				Certifications /Licenses	Facilities/ Personnel	SAM.Gov	Previous Experience	Years in Business	Financial Stability
Boykin, Utley	N/A	N/A	Yes	Y	Y	Yes	30 years	Yes	Y
Butler Law Firm	N/A	N/A	Yes	Y	Y	Yes	10 Years	Yes	Y
Butler Snow, LLC.	N/A	N/A	Yes	Y	Y	Yes	70 Years	Yes	Y
Kiefer & Kiefer	N/A	N/A	Yes	Y	Y	Yes	40 Years	Yes	Y
Wright Gray Harris, LLC	N/A	N/A	Yes	Y	Y	Yes	5 Years	Yes	Y
Transcendent Legal	X	X	X	X	X	X	X	X	X
Sher Garner Cahill Richter Klein & Hilbert	X	X	X	X	X	X	X	X	X

Review and verification of the above "checked" forms, the below listed vendor is hereby found responsible for award of this procurement.

Vendor Name: We are going to use all (5) vendors on a rotation basis .

Certified by: Name and Title Shaun Temple, Contract Administrator

PROCUREMENT SUMMARY-RFP 2024-033

REQUIREMENTS

A Solicit Request Routing Sheet for Professional Legal Services with attached scope of work was received by Procurement on August 16, 2024.

SOLICITATION

Request for Proposal (RFP) No. 2024-033 Public Notice was published in The Advocate. The Public Notice and the RFP 2024-033 were posted on the RTA website beginning 9/24/2024. The RFP submittal deadline was 10/24/24 at 2:00pm. Bid was extended to November 7, 2024 at 2:00 pm

RFP SUBMITTAL

Submittal deadline was on 10/24/2024 at 2:00pm. Bid was extended to November 7, 2024 at 2:00 pm
Shaun Temple handled the receipt of all submissions received. Seven (7) proposals were received. (2) bids were Non-Responsive.

DETERMINATION

Five (5) responsive proposals were received. Two (2) proposals were received but non-responsive due to the required forms not being submitted.

SUBMITTAL ANALYSIS

<u>Respondents</u>	<u>Required Forms</u>
Boykin, Utley	ALL SUBMITTED
Butler Law Firm	ALL SUBMITTED
Butler Snow, LLC	ALL SUBMITTED
Kiefer & Kiefer	ALL SUBMITTED
Wright Gray Harris, LLC	ALL SUBMITTED
Transcendent Legal	NON-RESPONSIVE
Sher Garner Cahill Richter	NON-RESPONSIVE
Klein & Hilbert, L.L.C.	

SUMMARY

An Administrative Review was prepared by Shaun Temple.

A technical evaluation was conducted on January 16, 2025, at 2:00 pm. The evaluation committee consisted of the following:

Gizelle Banks
Tracy Tyler
Michael Smith

The final combined scores for the technical evaluation are as follows:

Boykin, Utley	270
Butler Law Firm	273
Butler Snow, LLC	275
Kiefer & Kiefer	263
Wright Gray Harris, LLC	290

All (5) vendors will be on an On-Call rotation. Their proposals have been determined to be fair and reasonable, and the basis of the award is in the best interest of the Regional Transit Authority. It's my recommendation to award agreements in this manner.



Board Report and Staff Summary

File #: 25-028

Finance Committee

RTA Insurance Brokerage Services for Property and Casualty Coverages

DESCRIPTION: Authorization to award a contract for Insurance Brokerage Services for property and casualty coverages to Relation Insurance Services, Inc.	AGENDA NO: Click or tap here to enter text.
ACTION REQUEST: <input checked="" type="checkbox"/> Approval <input type="checkbox"/> Review Comment <input type="checkbox"/> Information Only <input type="checkbox"/> Other	

RECOMMENDATION:

Authorize the Chief Executive Officer to award a contract to Relation Insurance Services, Inc. for property and casualty insurance brokerage services for a term of three (3) years, with an option by RTA to renew for an additional two (2) years, in the amount not to exceed \$900,000.

ISSUE/BACKGROUND:

Relation Insurance Services, Inc.[fka Kennedy Financial Group/BRK Insurance Group, LLC] has been the insurance broker of record for RTA for since April 2011.

RTA recently issued a Request for Proposals [“RFP”] for an insurance broker of record to perform all necessary property and casualty insurance brokerage services. There were four (4) responsive bidders. Of these four (4) bidders, Relation Insurance Services, Inc. has been deemed the most qualified to provide these services to RTA on an ongoing basis.

DISCUSSION:

Relation Insurance Services, Inc.[fka Kennedy Financial Group/BRK Insurance Group, LLC] has historically performed its work as the RTA insurance broker of record for the acquisition of property and casualty insurance in an exemplary manner. These insurance coverages have included property/excess property, flood, public entity errors and omissions/employment practices liability, crime, overhead catenary, excess automobile liability/general liability, excess workers’ compensation, parametric hurricane, and cyber liability. The award of this contract to Relation Insurance Services, Inc. shall enable RTA to receive their professional services without interruption. Notably, their capability, professional competence, and resources will provide RTA with optimal insurance brokerage services, including marketing and insurance placement, for the next three (3) years.

FINANCIAL IMPACT:

\$900,000 [\$300,000 per year for a three (3) year term].

Funds for this contract are available from the RTA Operational Budget

RTA Budget Code: 01-8300-02-7070-169-00-00-00000-00000

NEXT STEPS:

Proceed with the execution of this contract with Relation Insurance Services, Inc. as set forth above.

ATTACHMENTS:

1. Resolution for Insurance Brokerage Services [Property and Casualty]
2. Procurement Summary
3. Administrative Review Form
4. Scope of Work
5. RFP# 2025-007
6. Addendum #1
7. Addendum #2
8. Relation Insurance Services, Inc. Proposal

Prepared By: Marc Popkin
Title: Risk Management Counsel

Reviewed By: Tracy Tyler
Title: Chief Legal Officer

Reviewed By: Gizelle Banks
Title: Chief Financial Officer



Lona Edwards Hankins
Chief Executive Officer

3/11/2025

Date



RESOLUTION NO. _____

STATE OF LOUISIANA

PARISH OF ORLEANS

**AUTHORIZATION TO AWARD A CONTRACT FOR PROPERTY AND CASUALTY
INSURANCE BROKERAGE SERVICES TO RELATION INSURANCE SERVICES, INC.**

Introduced by Commissioner _____, seconded by
Commissioner _____.

WHEREAS, the RTA issued a Request for Proposals solicitation (RFP) #2025-007 for Property and Casualty Insurance Brokerage Services for an initial term of three (3) years, with an option by RTA to renew for an additional two (2) years; and

WHEREAS, four (4) proposals were received and four (4) were deemed responsive; and

WHEREAS, RTA staff evaluated all elements of the submittals in accordance with requirements prescribed by the RTA, Louisiana Public Bid Law and the Federal Transit Administration; and

WHEREAS, the following vendor was evaluated and received the highest score: Relation Insurance Services, Inc.; and

WHEREAS, the RTA staff evaluated all cost components submitted by the vendor and determined the price to be fair and reasonable; and



RESOLUTION NO. _____

Page 2

WHEREAS, the price for the services of Relation Insurance Services, Inc. as the most qualified bidder, is in the amount not to exceed **THREE HUNDRED THOUSAND AND 00/00 DOLLARS (\$300,000)** annually for the initial term of three (3) years, for a total of **NINE HUNDRED THOUSAND AND 00/00 DOLLARS (\$900,000)**; and

WHEREAS, funding is available through the RTA operational budget [budget code: 01-8300-02-7070-169-00-00-00000-00000] for this three (3) year term.

NOW, THEREFORE, BE IT RESOLVED by the Board of Commissioners of the RTA that the Chairman of the Board, or his designee, is authorized to execute a contract with Relation Insurance Services, Inc. in the amount not to exceed **NINE HUNDRED THOUSAND AND 00/00 DOLLARS (\$900,000)**.

THE FOREGOING WAS READ IN FULL, THE ROLL WAS CALLED ON THE ADOPTION THEREOF AND RESULTED AS FOLLOWS:

YEAS: _____

NAYS: _____

ABSTAIN: _____

ABSENT: _____

AND THE RESOLUTION WAS ADOPTED ON THE _____ DAY OF MARCH, 2025.

FRED NEAL, JR.
CHAIRMAN
RTA BOARD OF COMMISSIONERS

PROCUREMENT SUMMARY-RFP 2025-007

REQUIREMENTS

A Solicit Request Routing Sheet for Insurance Broker Services with attached scope of work was received by Procurement on July 11, 2024.

SOLICITATION

The Public Notice and the RFP 2025-007 was posted on the RTA website beginning 1/17/25. The RFP submittal deadline was 2/19/25 at 4:00pm. This is the second solicitation. The first solicitation (RFP 2024-024) was cancelled due to a change in scope of work.

RFP SUBMITTAL

Submittal deadline was on 2/19/25 at 4:00pm. Briana Howze handled the receipt of all submissions received. Four (4) proposals were received.

DETERMINATION

Four (4) responsive proposals were received and determined to be responsive.

SUBMITTAL ANALYSIS

Respondents

Alliant
Relation Insurance Services
Gallagher
Higginbotham

Required Forms

All Required Documents
All Required Documents
All Required Documents
All Required Documents

SUMMARY

An Administrative Review was prepared by Briana Howze.

A technical evaluation was conducted on Monday March 10, 2025 at 10:00 am. The evaluation committee consisted of the following:

Marc Popkin
Ryan Moser
Yolanda Rodriguez

The final combined scores for the technical evaluation are as follows:

Alliant	177
Relation Insurance Services	273
Gallagher	181
Higginbotham	171

Relation Insurance Services has been determined to be fair and reasonable and is recommended for award.

Regional Transit Authority
Administrative Review Form

Project Name: Insurance Broker Services

Type of Solicitation: RFP 2025-007 DBE/SBE Participation Goal: 0% Number of Respondents: 4

Prime, Primary Contact and Phone Number	DBE and Non-DBE Subconsultants	DBE Commitment Percentage	Price (RFP and ITB ONLY)
Alliant	N/A	0%	\$0.00
Relation Insurance Services	N/A	0%	\$300,000.00
Gallagher	N/A	0%	\$550,000.00
Higginbotham	N/A	0%	\$100,000.00

*Indicates certified DBE or SLDBE firm that will contribute to the project's participation goal

Prime Firm Name	Required Items								
	LA Uniform Public Work Bid	Non-Collusion	Debarment Prime	Debarment Lower	Restrictions on Lobbying	Buy America Compliance	Participant Info	Affidavit of Fee Disposition	Addenda
Alliant	N/A	Y	Y	Y	Y	Y	Y	Y	Y
Relation Insurance Services	N/A	Y	Y	Y	Y	Y	Y	Y	Y
Gallagher	N/A	Y	Y	Y	Y	Y	Y	Y	Y
Higginbotham	N/A	Y	Y	Y	Y	Y	Y	Y	Y

Review and verification of the above required forms, the below listed vendor is hereby found responsive to this procurement.

Vendor Name: Relation Insurance Services

Certified by: Name and Title Briana Howze, Contract Administrator

Procurement Personnel Only

Prime Firm Name	Bid Bond	Insurance	Responsiveness Determination	Responsible Determination						
				Certifications /Licenses	Facilities/ Personnel	SAM.Gov	Previous Experience	Years in Business	Financial Stability	LA License No. if required
Alliant	N/A					Y	Y			
Relation Insurance Services	N/A					Y	Y			

Gallagher					Y	Y			
Higginbotham					Y	Y			

Review and verification of the above "checked" forms, the below listed vendor is hereby found responsible for award of this procurement.

Vendor Name: Relation Insurance Services.

Certified by: Name and Title Briana Howze, Contract Administrator

SCOPE OF SERVICES – PROPERTY & CASUALTY INSURANCE

Overview:

To provide Insurance Brokerage Services pursuant to industry standards related to a transportation entity such as RTA. This includes soliciting quotations from insurance providers in specified markets, and performing the research and evaluation necessary and appropriate to recommend the respective insurance provider(s) to the RTA Board for approval.

The Broker must have ten (10) or more years of experience with insurance accounts specific to the field of public transit or similar public entity.

The initial contract term shall be a period of three (3) years, renewable for one (1) two-year period at the option of RTA, upon the same terms and conditions, and subject to funding by the RTA. The initial contract effective date is anticipated to be on or about January 1, 2025.

The Broker shall work closely with the RTA's Executive Staff, including Risk Management Counsel, to identify and evaluate RTA risk exposures, and provide professional advice regarding the appropriate types and levels of coverage, as well as retention levels, to secure primary and/or excess insurance for RTA's insurable risks. The objective is to place insurance in accordance with the desired retentions and limits designated by RTA. The Broker shall make available to RTA any and all resources at its disposal to collect, organize and review data required for marketing and placement of insurance.

Information regarding the RTA's current coverage is included in the Exhibits section of this RFP.

Required Insurance Coverages:

The required insurance coverages to be provided include but are not limited to:

- Primary Flood Insurance for RTA Property ["NFIP Flood Insurance"] typically through Wright National or similar carrier
- Property Insurance
- Excess Property Insurance
- Public Entity Errors & Omissions and Employment Practices Liability Insurance [aka "Public Officials" Insurance]
- Crime Insurance
- Overhead Catenary ["OCS"] Insurance
- Excess Automobile Liability and General Liability Insurance ["Excess AL/GL" Insurance]
- Automobile Physical Damage Insurance ["APD" Insurance]
- Excess Workers' Compensation Insurance for RTA Employees
- Parametric Insurance for Named Storms [i.e. Parametric Hurricane Insurance]
- Cyber Liability Insurance
- Any and all other insurance coverages favorable to RTA to minimize risk and exposure

Insurance Broker Services:

These Client Services shall include:

- Market and solicit proposals from qualified carriers, including canvassing insurance markets, reviewing suitable manuscript policies, and policy/premium negotiations on behalf of RTA with qualified carriers
- Bind insurance, administer policies, and serve as RTA liaison with the respective insurance providers in connection with the above-listed coverages
- Administer and/or monitor RTA claims appropriate to the type of insurance coverage
- Evaluate insurance provider costs and performance, and advise the RTA on any and all proposed changes to policies and/or provider(s) in the best interests of the RTA
- Analyze exposure, claims, coverage forms, and current program data to determine various options in program structure and provide recommendations to make the program more effective and efficient
- Analyze insurance market trends, and report to RTA the effect those trends will have on pricing and coverage availability
- Timely solicit proposals and quotes from insurance providers as to renewal of existing insurance coverages/policies throughout the term of the contract
- Act on behalf of the RTA in analyzing and negotiating renewal rates to obtain the most competitive pricing annually
- Prepare related reports as required by industry standard and/or upon reasonable request of the RTA for management review
- Ensure the receipt of all binders, policies, policy endorsements, etc. within a designated timeframe, verify their accuracy, and obtain any and all necessary revisions
- Prepare certificates of insurance and endorsements, as requested, within a reasonable timeframe
- Maintain insurance records in good order, inclusive of policies, claims history, and related documentation
- Assist RTA when other coverages may need to be added during the term of the contract, at no additional cost
- Provide ongoing advisory services to ensure best possible coverage
- Work with RTA's Third Party Administrator ["TPA"] for Excess AL/GL and Workers' Compensation to coordinate claims activity
- Facilitate RTA on-site and online meetings with insurance representatives/underwriters
- Meet with RTA staff as appropriate to recommend risk mitigation strategies and reduce premium costs
- Assist RTA in submittal of insurance data required for governmental applications (e.g. application with GOHSEP for State of Louisiana Insurance Commissioner's Certification)

PUBLIC NOTICE
REGIONAL TRANSIT AUTHORITY
INSURANCE BROKERAGE SERVICES & EMPLOYEE BENEFITS
REQUEST FOR PROPOSALS (RFP) #2025-007

Project Description: The Regional Transit Authority (RTA) is seeking a vendor to provide Insurance Brokerage Services & Employee Benefits per specifications in RFP 2025-007 .

How to Obtain a copy of the RFP: Scope of Work and further information concerning the RFP may be obtained beginning January 17, 2025, from the RTA's Procurement website at <https://norta.procurement.com/home>. You will be required to first register on this website. The RFP can also be obtained at Regional Transit Authority's website at <http://www.norta.com>

Responding to RFP: Proposals shall be submitted through RTA's Procurement website on or before 4:00 P.M., Friday, February 14, 2025. Any questions or further information concerning this RFP may be submitted through <https://norta.procurement.com/home> beginning on January 17, 2025. Only written questions submitted through <https://norta.procurement.com/home> shall be considered official. All answers to questions shall be by formal addenda posted to the website under RFP #2025-007.

RTA in accordance with 49 Code of Federal Regulations (CFR) Part 26 has an obligation to ensure nondiscrimination of Disadvantaged Business Enterprises (DBEs) and to comply with all federal, state and local regulations relative to utilization of DBEs on publicly funded projects. The RTA is committed to utilization of DBEs on all federally funded projects toward attainment of the agency's established overall goal of 32%. **No DBE goal has been established for this project as there are no subcontracting opportunities on this project.**

Notice to all offerors is hereby provided that in accordance with all applicable federal, state and local laws the RTA will ensure that DBEs are afforded full opportunity to submit offers and responses to this solicitation and to participate in any contract consummated pursuant to this advertisement. Additionally, no offeror will be discriminated against on the basis of age, sex, race, color, religion, national origin, ethnicity or disability.

The RTA reserves the right to accept or reject any and all submittals.

Lona Hankins
Chief Executive Officer
Regional Transit Authority

REQUEST FOR PROPOSALS
FROM
REGIONAL TRANSIT AUTHORITY

SUBJECT: Insurance Brokerage Services & Employee Benefits

DATE: January 17, 2025

REQUEST FOR PROPOSALS NO. 2025-007

PROPOSAL RECEIPT DEADLINE: Friday, February 14, 2025 - 4:00 PM

The Regional Transit Authority Request for Proposals for the services set forth above in accordance with the scope of work enclosed herewith.

Proposals **MUST** be received at the RTA's Offices by the date and time set as the Proposal Receipt Deadline.

Enclosures ("X" indicates item enclosed)

- X** Instructions to Proposers
- X** General Provisions
- X** Federal Requirements
- X** Evaluation
- X** Attachments

TABLE OF CONTENTS

I. INSTRUCTIONS TO PROPOSERS

PAGE NUMBER

1.1	Proposals Submittal	1
1.2	Submittal Submissions	1
1.3	Submittal Review Procedures	1
1.4	Contract Documentation	3
1.5	Cost of Proposal	3
1.6	Proposal Postponement and Addenda	3
1.7	Cancellation of Request for Proposals	4
1.8	Proposal Rejection	4
1.9	Single Proposal Response	4
1.10	Proposal Withdrawal	4
1.11	Acceptance of Proposals	4
1.12	Evaluation of Proposals	4
1.13	Award Procedure	5
1.14	Offers	5
1.15	Addenda	5

II. GENERAL PROVISIONS

2.1	Written Change Orders/Amendments	6
2.2	Change Order/Amendment Procedure	6
2.3	Omissions	6
2.4	Priority	6
2.5	Communications	6
2.6	Interests of Members of, or Delegates to Congress	7
2.7	Conflict of Interest	7
2.8	Equal Employment Opportunity	8
2.9	Privacy Requirements	8
2.10	Indemnification	8
2.11	Performance	9
2.12	Status of Contractor and Its Employees	9
2.13	Insurances and Licenses	9
2.14	Subcontractors	9
2.15	Assumption of Risk of Loss	9
2.16	Acceptance	10
2.17	Quality Inspection	10
2.18	Correction by Contractor	10
2.19	Unavoidable Delays	10
2.20	Notification of Delay	10
2.21	Request for Extension	11
2.22	Access Requirements for Individuals with Disabilities	11
2.23	Application of Federal, State and Local Laws and Regulations	12
2.24	Contract Period	12
2.25	No Obligation by the Federal Government	12
2.26	Federal Changes	13
2.27	Incorporation of Federal Transit Administration (FTA) Terms	13
2.28	Exclusionary or Discriminatory Specifications	13
2.29	Geographic Restrictions	13

2.30	Prompt Payment	13
2.31	Confidentiality	15
2.32	Disputes	15
2.33	Ownership of Documents	16
2.34	State and Local Law Disclaimer	16
2.35	Participant Information	16
2.36	Non-Collusion Affidavit	16
2.37	Regional Transit Authority General Provisions	16
2.38	Disadvantaged Business Enterprise (DBE)	16

III. FEDERAL REQUIREMENTS

3.1	Access to Records	17
3.2	Buy America Requirements	18
3.3	Pre-Award And Post-Delivery Audits	18
3.4	Cargo Preference Requirement	18
3.5	Clean Air Act And Federal Water Pollution Control Act	19
3.6	Civil Rights Laws And Regulations	20
3.7	Disadvantaged Business Enterprise (DBE)	21
3.8	Employee Protections	22
3.9	Energy Conservation	23
3.10	Fly America	23
3.11	Government-Wide Debarment And Suspension	23
3.12	Lobbying Restrictions	25
3.13	No Government Obligation To Third Parties	25
3.14	Patent Rights And Rights In Data	25
3.15	Program Fraud And False Or Fraudulent Statements & Related Acts	27
3.16	Recycled Products	28
3.17	Safe Operation Of Motor Vehicles	28
3.18	Substance Abuse Requirements	29
3.19	Termination	29
3.20	Contract Work Hours & Safety Standard Act	30

IV. EVALUATION

Method	31
Administrative Evaluation	31
Evaluation Criteria	32
Contract Award	33
Overhead Rates	33

ATTACHMENTS	Scope of Work
	Supplier Checklist

INSTRUCTIONS TO PROPOSERS

1.1 PROPOSALS

Each submittal must include a Letter of Interest that addresses the suggested structure or organization of the proposed team (prime and sub-consultants), a detailed description of your team's approach and capability to handle project-specific issues, a schedule of the proposed work, and any other information that may assist the RTA in making a selection. Letters of Interest should be concise and limited to three (3) pages.

Proposals shall provide a straight forward, concise delineation of the proposer's capability to satisfy the requirements of the Request for Proposals. Each proposal shall be submitted in the requested format, and provide all pertinent information including but not limited to information relevant to personnel assignments, specifications/scope of work, work completion, schedules, etc., as provided in this Request for Proposals. Each proposal shall be signed in ink by a duly authorized officer of the company.

1.2 PROPOSAL SUBMISSIONS

Proposals can be sent electronically through RTA's ProcureWare system and uploaded through our electronic system <https://norta.procureware.com/home> until 4:00 P.M., on the date established as the submittal receipt deadline or upon request a hardcopy may be mailed to: Regional Transit Authority, Attn: Procurement Department, 2817 Canal Street, New Orleans, LA 70119. Proposals received after the specified date shall be considered late and, therefore, shall not be considered for award. Each proposal shall be in the form specified in this Request for Proposals, and shall be in a sealed envelope with the name of the Proposer, the date scheduled as the proposal receipt deadline, and the title of the Request for Proposals marked on the outside.

1.3 PROPOSER REVIEW PROCEDURE

For the purposes of this paragraph, all submissions must be received by the RTA no later than 4:00 p.m. (Central time) on the date specified as the deadline for the submission.

A. Request for Modification or Clarification

This section establishes procedures for proposers to seek review of this Request for Proposals and any addenda. A proposer may discuss this Request for Proposals and any addenda with the RTA. Such discussions do not, however, relieve proposers from the responsibility of submitting written, documented requests.

Proposers may submit to the RTA requests for interpretations, clarifications or modifications concerning any term, condition and/or specification included in this Request for Proposals and/or in any addendum hereto. Any such request must be received by the RTA, in writing, not less than **SEVEN (7) calendar days** before the date of scheduled

proposal receipt deadline. All requests must be accompanied by all relevant information supporting the request for modification, interpretation, clarification or addendum of this solicitation.

RTA will issue a written determination relative to each request made pursuant to this procedure. The written determination must be mailed or otherwise furnished to all proposers at least **THREE (3) calendar days** before the date scheduled as the proposal receipt deadline.

b. Protest Procedures

The following is an explanation of the RTA protest procedures which must be followed completely before all administrative remedies are exhausted.

Any person who is aggrieved in connection with the solicitation or award of a contract may protest to the Director of Procurement/RTA. Protests shall be submitted in writing specifically identifying the area of protest and containing any support data, test results, or other pertinent information substantiating the appeal. A protest with respect to a solicitation must be submitted in writing to the RTA at least seven (7) calendar days prior to proposal receipt deadline. A protest with regard to the award of a contract shall be submitted, in writing, within seven (7) calendar days after award of the contract.

Prior to any action in court, the Director of Procurement/RTA shall have the authority to settle or resolve a protest from an aggrieved person concerning the solicitation or award of a contract.

If the protest is not resolved by mutual agreement, the Director of Procurement/RTA or his designee shall within thirty (30) calendar days of protest issue a decision in writing. The decision shall:

1. State the reasons for the action taken; and
2. Inform the protestor of his/her right to administrative and judicial review.

A copy of this decision shall be mailed or otherwise furnished immediately to the protestant and any other party intervening. This decision shall be final and conclusive unless:

1. The decision is fraudulent; or
2. The person adversely affected by the decision has submitted a timely administrative appeal to the CEO/RTA.

In the event of a timely protest under these regulations, the RTA shall not proceed further with the solicitation or with the award of the contract unless the Director of Procurement/RTA makes a written determination that the award of the contract is necessary without delay to protect the substantial interests of the RTA.

The CEO/RTA shall have the authority to review and determine any appeal by an aggrieved person from a determination by the Director of Procurement/RTA or his designee.

The aggrieved person must file an appeal within five (5) calendar days of receipt of a decision from the Director of Procurement/RTA.

On any appeal of the decision of the Director of Procurement/RTA, the CEO/RTA shall decide within thirty (30) calendar days whether the solicitation or award was made in accordance with the constitution, statutes, regulations, and the terms and conditions of the solicitation. Any prior determination by the Director of Procurement/RTA or his designee shall not be final or conclusive.

A copy of the CEO's/RTA decision shall be mailed or otherwise furnished immediately to the protestant or any other party intervening.

The decision of the CEO/RTA shall be final and conclusive unless:

1. The decision is fraudulent; or
2. The person adversely affected by the decision has timely appealed to FTA after having exhausted the local protest procedures stated above.

The RTA reserves the right to designate any person(s) other than the CEO/RTA or the Director of Procurement/RTA to perform the duties provided for in this Paragraph.

Any appeal to FTA under these protest procedures will be made pursuant to Circular 4220.1F, as amended.

1.4 CONTRACT DOCUMENTATION

Any contract resulting from this solicitation shall contain the terms and conditions included in this Request for Proposals and any addenda issued pursuant hereto.

1.5 COST OF PROPOSAL

Any costs incurred by proposers responding to this Request for Proposals in anticipation of receiving a contract award will not be reimbursed by the RTA. Payments will only be made pursuant to a contract between the RTA and the successful proposer.

1.6 PROPOSAL POSTPONEMENT AND ADDENDA

The RTA reserves the right to amend the instructions, general conditions, special conditions, plans, scope of work, and specifications of this solicitation up to the deadline date for proposal receipt. Copies of such addenda shall be furnished to all prospective proposers. Where such addenda require changes in the services or prices quoted, the final date set for proposal receipt may be postponed by such number of days as in the opinion of the RTA shall enable prospective proposers to revise proposals.

1.7 CANCELLATION OF REQUEST FOR PROPOSALS

The RTA reserves the right to cancel this Request for Proposals in whole or in part upon written determination by the Director of Procurement/RTA that such cancellation is in the best interest of the RTA.

1.8 PROPOSAL REJECTION

The RTA reserves the right to accept or reject any and all proposals submitted.

1.9 SINGLE PROPOSAL RESPONSE

If only one proposal is received in response to this Request for Proposals, a detailed cost proposal may be requested of the single proposer. A cost/price analysis and evaluation and/or audit may be performed in order to determine if the offer is fair and reasonable. Award of a contract to the proposer submitting the only proposal received in response to this Request for Proposals may be subject to approval by the FTA.

1.10 PROPOSAL WITHDRAWAL

Prior to the date and time set for the Proposal Receipt Deadline, proposals may be modified or withdrawn by the proposer's authorized representative in person, or by written, facsimile or electronic notice. If proposals are modified or withdrawn in person, the authorized representative shall make his identity known and shall sign a receipt for the proposal. Written, facsimile or electronic notices shall be received in the RTA Canal St. offices no later than the date scheduled as the proposal receipt deadline. After the Proposal Deadline, proposals may not be withdrawn for sixty (60) calendar days.

1.11 ACCEPTANCE OF PROPOSALS

Each proposal shall be submitted with the understanding that it is subject to negotiation at the option of RTA. Upon acceptance in writing by RTA of the final offer to furnish any and all of the services described herein, the parties shall promptly execute the final contract documents. The written contract shall bind the Proposer to furnish and deliver all services as specified herein in accordance with conditions of said accepted proposal and this Request for Proposals, as negotiated.

1.12 EVALUATION OF PROPOSALS

The evaluation criteria are provided in this Request for Proposals. The proposer receiving the highest point total during the evaluation phase of the selection process may be called in for negotiations. The contract will be awarded based on the Best Value to the RTA. RTA shall have the right to conduct any reviews it deems necessary and audit the business records of any and all proposers to determine the fairness and reasonableness of the offer. RTA reserves the right to award this contract without conducting negotiations.

1.13 AWARD PROCEDURE

Within a reasonable time after the proposal receipt deadline, the RTA will transmit the contract documents to the Contractor. The contract documents will, at a minimum, consist of this Request for Proposals and any addenda thereto, the Contractor's proposal, RTA's standard contract provisions and provisions required by FTA.

1.14 OFFERS

Each proposal submitted shall include all labor, materials, tools, equipment, and other costs necessary to fully complete the scope of services pursuant to the specifications provided herein. Any omissions derived from such specifications which are clearly necessary for the completion of the work specified herein shall be considered a portion of this Request for Proposals.

1.15 ADDENDA

Proposers shall acknowledge receipt of all addenda to this Request for Proposals. Acknowledged receipt of each addendum shall be clearly established and included with each proposal. The undersigned acknowledges receipt of the following addenda.

Addendum No. _____, dated _____

Addendum No. _____, dated _____

Addendum No. _____, dated _____

Company Name

Company Representative

RFP 2025-007

II. GENERAL PROVISIONS

2.1 WRITTEN CHANGE ORDERS/AMENDMENTS

This contract may be changed/ amended in any particular allowed by law upon the written mutual agreement of both parties.

2.2 CHANGE ORDER/AMENDMENT PROCEDURE

Within ten (10) calendar days after receipt of the written change order to modify the contract, the Contractor shall submit to the RTA a detailed price and schedule proposal for the work to be performed. This proposal shall be accepted or modified by negotiations between the Contractor and the RTA. At that time, a detailed modification shall be executed in writing by both parties. In the event that federal funds are used in this procurement, the FTA may reserve the right to concur in any change order or any dispute arising under such change order. Disagreements that cannot be resolved by negotiation shall be resolved in accordance with the contract disputes clauses. Regardless of any disputes, the Contractor shall proceed with the work ordered, if the RTA has obtained the concurrence of FTA, should such concurrence be required. Regardless of any other requirement herein, RTA shall negotiate profit as a separate element of cost for any change order or amendment to any contract awarded pursuant to this solicitation.

2.3 OMISSIONS

Notwithstanding the provision of drawings, technical specifications or other data by the RTA, the Contractor shall supply all resources and details required to make the supplies complete and ready for utilization even though such details may not be specifically mentioned in the drawings and specifications.

2.4 PRIORITY

In the event of any conflicts between the description of the supplies and/or services in the Technical Specifications and drawings and other parts of this Request For Proposals, the Technical Specifications and drawings shall govern.

2.5 COMMUNICATIONS

All official communications in connection with this contract shall be in writing. Respondents to this solicitation or persons acting on their behalf may not contact, between the release of the solicitation and award, any employee or officer of RTA or the Regional Transit Authority, including the Board of Commissioners, concerning any aspect of this

solicitation, except in writing to the procurement officer or as provided in the solicitation documents. Violation of this provision may be grounds for rejecting a response.

2.6 INTEREST OF MEMBERS OF, OR DELEGATES TO CONGRESS

In accordance with 18 U.S.C. Subsection 431, no member of, or delegates to, the Congress of the United States shall be admitted to a share or part of this contract or to any benefit arising there from.

2.7 CONFLICT OF INTEREST

No Board Member, employee, officer or agent, or employee of such agent of the RTA shall participate in the selection or in the award or administration of a contract if a conflict of interest, real or apparent, would be involved. Such a conflict would arise when:

- a. The Board Member, employee, officer or agent, or employee of such agent;
- b. Any member of his immediate family;
- c. His or her partner; or
- d. An organization that employs, or is about to employ any of the above, has a direct or indirect, present or future financial or other interest in the firm selected for award.

The RTA's Board Members, officers, employees or agents shall neither solicit nor accept gratuities, favors or anything of monetary value from contractors, potential contractors or parties of sub agreements.

Each entity that enters into a contract with the RTA is required, prior to entering into such contract, to inform the RTA of any real or apparent organizational conflicts of interest. An organizational conflict of interest exists when the contractor is unable or potentially unable to provide objective assistance or advice to the RTA due to other activities, relationships, contracts, or circumstances; when the contractor has an unfair competitive advantage through obtaining access to nonpublic information during the performance of an earlier contract; and during the conduct of an earlier procurement, the contractor has established the ground rules for a future procurement by developing specifications, evaluation factors, or similar documents, in accordance with Chapter VI, 2.a.(4)(h) of FTA C 4220.1F.

2.8 EQUAL EMPLOYMENT OPPORTUNITY

The Contractor shall comply with Executive Order No. 11246 as amended, entitled "Equal Employment Opportunity" as supplemented in Department of Labor Regulations

(41 C.F.R. Paragraph 60). In connection with the execution of this Agreement, the Contractor shall not discriminate against any employees or applicant for employment because of race, religion, color, sex, age, or national origin. The Contractor shall take affirmative action to ensure that applicants are employed and that employees are treated during their employment without regard to their race, religion, color, sex, age, or national origin. Such actions shall include, but not be limited to, the following: employment, upgrading, demotion, or transfer, recruitment or recruitment advertising; layoff or termination, rates of pay or other forms of compensation, and selection for training, including apprenticeship. Contractor further agrees to insert a similar provision in all subcontracts, except subcontracts for standard commercial supplies or raw materials.

2.9 PRIVACY REQUIREMENTS

The following requirements apply to the Contractor and its employees that administer any system of records on behalf of the Federal Government under any contract:

(1) The Contractor agrees to comply with, and assures the compliance of its employees with, the information restrictions and other applicable requirements of the Privacy Act of 1974, 5 U.S.C. § 552a. Among other things, the Contractor agrees to obtain the express consent of the Federal Government before the Contractor or its employees operate a system of records on behalf of the Federal Government. The Contractor understands that the requirements of the Privacy Act, including the civil and criminal penalties for violation of that Act, apply to those individuals involved, and that failure to comply with the terms of the Privacy Act may result in termination of the underlying contract.

(2) The Contractor also agrees to include these requirements in each subcontract to administer any system of records on behalf of the Federal Government financed in whole or in part with Federal assistance provided by FTA.

2.10 INDEMNIFICATION

The Contractor covenants and agrees to fully defend, protect, indemnify and hold harmless the RTA, and RTA, their directors, officers, employees, agents, and assigns from and against all liability, including strict liability, claims, demands, and causes of action brought by others against RTA, and/or RTA, and expenses, including but not limited to reasonable attorney's fees; and expense incurred in defense of RTA, and/or RTA arising out of, or in any way incidental to, or in connection with the work hereunder, and other activities by contractor; provided, however, that such indemnification shall apply only to the extent permitted by applicable law, and except and to the extent such liability, claim, demand or cause of action results from RTA's negligence.

2.11 PERFORMANCE

Contractor shall perform all work diligently, carefully and in a good and workmanlike manner and shall furnish all labor, supervision, machinery, equipment, material and supplies necessary therefore. Contractor shall obtain and maintain all permits and licenses required by public authorities in connection with performance of the work, and, if permitted to subcontract, shall be fully responsible for all work performed by subcontractors. Contractor shall conduct all operations in Contractor's own name and as an independent contractor, and not in the name of, or agent for RTA.

2.12 STATUS OF CONTRACTOR AND ITS EMPLOYEES

For all purposes specified under the terms of this Agreement the Contractor shall be considered an independent contractor as defined in R.S. 23:1021 (5), and as such, the RTA shall not be liable to the Contractor for benefits or coverage provided by the Workers' Compensation Law of the State of Louisiana (R.S. 23:1021 et seq.), and further, under the provisions of R.S. 23:1034, no person employed by the Contractor shall be considered an employee of the RTA for the purpose of Workers' Compensation coverage.

2.13 INSURANCES

The contractor shall, upon request by the RTA, submit a copy of their standard insurance certificates for this project. During the term of this Agreement, the Contractor shall obtain and maintain the following types and amounts of insurance naming the Regional Transit Authority as an additional insured. The Contractor shall furnish to the RTA certificates showing types, amounts, class of operations covered, effective dates and dates of expiration of policies:

- A) Worker's Compensation Insurance as required by Louisiana Law;
- B) Vehicle Liability Insurance in the amount of \$1,000,000.00; and
- C) General Liability Insurance in the amount of \$1,000,000.

2.14 SUBCONTRACTORS

No portion of this contract may be, reassigned, transferred, or sublet without the written approval of the RTA. If allowed to subcontract, no subcontractor may be replaced without the written approval of the RTA.

2.15 ASSUMPTION OF RISK OF LOSS

Prior to acceptance, Contractor shall bear the risk of loss of the supplies, except that upon delivery, as defined in this Request For Proposals, the RTA will bear the risk of loss due to the negligence of the RTA.

2.16 ACCEPTANCE

Within 7 days after delivery, the RTA, its agents or assigns will conduct acceptance inspection. Acceptance shall be conditioned upon satisfactory results of such inspection, promptly communicated in writing to the Contractor, subject however, to revocation upon discovery of defects.

2.17 QUALITY INSPECTION

All goods and services installed and supplied shall be good quality and free from any defects, and shall at all times be subject to RTA's inspection; but neither RTA's inspection nor failure to inspect shall relieve Contractor of any obligation hereunder. If, in RTA's opinion, any goods or service (or component thereof) fails to conform to specifications or is otherwise defective, Contractor shall promptly replace or correct same at Contractor's sole expense. No acceptance or payment by RTA shall constitute a waiver of the foregoing, and nothing herein shall exclude or limit any warranties implied by law.

2.18 CORRECTION BY CONTRACTOR

After non-acceptance of the work, the Contractor shall begin implementing correction procedures within five (5) calendar days after receiving notification from the RTA. The RTA will make the site timely with Contractor's correction schedule. The Contractor shall bear all expense incurred to complete correction of the work after non-acceptance, and Contractor shall diligently implement correction procedures.

2.19 UNAVOIDABLE DELAYS

If completion of the work furnished under this contract should be unavoidably delayed, the RTA may extend the time for satisfaction of the Contractor's obligations pursuant thereto for a number of days determined by RTA to be excusable due to unavoidability. A delay is unavoidable only if the delay was not reasonably expected to occur in connection with or during the Contractor's performance, and was not caused directly or substantially by acts, omissions, negligence or mistakes of the Contractor, the Contractor's suppliers or their agents and was substantial and in fact caused the Contractor to miss completion dates and could not adequately have been guarded against by contractual or legal means.

2.20 NOTIFICATION OF DELAY

The Contractor shall notify the RTA as soon as the Contractor has, or should have, knowledge that an event has occurred or will occur which will delay progress or

completion. Within five (5) days there from, the Contractor shall confirm such notice in writing furnishing as much detailed information as is available.

2.21 REQUESTS FOR EXTENSION

The Contractor agrees to supply, as soon as such data are available, any/all reasonable proof required by the RTA to make a decision relative to any request for extension. The RTA shall examine the request and any documents supplied by the Contractor, and RTA shall determine if the Contractor is entitled to an extension and the duration of such extension. The RTA shall notify the Contractor of this decision in writing. It is expressly understood and agreed that the Contractor shall not be entitled to damages or compensation, and shall not be reimbursed for losses on account of delays resulting from any cause under this provision.

2.22 ACCESS REQUIREMENTS FOR INDIVIDUALS WITH DISABILITIES

During the performance of this contract, the contractor, for itself, its assignees and successors in interest agree to comply with all applicable requirements of the Americans with Disabilities Act of 1990 (ADA), 42 U.S.C. sections 12101 et seq.; section 504 of the Rehabilitation Act of 1973, as amended, 29 U.S.C. section 794; section 16 of the Federal Transit Act, as amended, 49 U.S.C. app. section 1612; and the following regulations and any amendments thereto:

- (a) U.S. DOT regulations, "Transportation Services for Individuals with Disabilities (ADA)," 49 C.F.R. Part 37;
- (b) U.S. DOT regulations, "Nondiscrimination on the Basis of Handicap in Programs and Activities Receiving or Benefiting from Federal Financial Assistance," 49 C.F.R. Part 27;
- (c) U.S. DOT regulations, "American With Disabilities (ADA) Accessibility Specifications for Transportation Vehicles," 49 C.F.R. Part 38;
- (d) Department of Justice (DOJ) regulations, "Nondiscrimination on the Basis of Disability in State and Local Government Services," 28 C.F.R. Part 35;
- (e) DOJ regulations, "Nondiscrimination on the Basis of Disability by Public Accommodations and in Commercial Facilities," 28 C.F.R. Part 36;
- (f) General Services Administration regulations, "Accommodations for the Physically Handicapped," 41 C.F.R. Subpart 101-19;

- (g) Equal Employment Opportunity Commission, "Regulations to Implement the Equal Employment Provision of the Americans with Disabilities Act," 29 C.F.R. Part 1630;
- (h) Federal Communications Commission regulations, "Telecommunications Relay Services and Related Customer Premises Equipment for the Hearing and Speech Disabled," 47 C.F.R. Part 64, Subpart F; and
- (i) FTA regulations, "Transportation of Elderly and Handicapped Persons," 49 C.F.R. Part 609.

2.23 APPLICATION OF FEDERAL, STATE AND LOCAL LAWS AND REGULATIONS

(a) Federal Laws and Regulations

The Federal requirements (laws, regulations policies, and related administratively) contained in this contract may change (from time to time) after the date the contract has been executed. Any changes in federal requirements shall apply to this contract and be incorporated therein.

(b) State or Territorial Law and Local Law

This contract shall be entered into in the State of Louisiana and shall be governed and/or construed in accordance with the laws and jurisprudence of the State of Louisiana, except to the extent that a Federal Statute or regulation preempts State or territorial law.

2.24 CONTRACT PERIOD

THE TERM OF THIS CONTRACT SHALL BE SET FORTH IN THE CONTRACT AGREEMENT.

2.25 NO OBLIGATION BY THE FEDERAL GOVERNMENT

- (1) The Purchaser and Contractor acknowledge and agree that, notwithstanding any concurrence by the Federal Government in or approval of the solicitation or award of the underlying contract, absent the express written consent by the Federal Government, the Federal Government is not a party to this contract and shall not be subject to any obligations or liabilities to the Purchaser, Contractor, or any other party (whether or not a party to that contract) pertaining to any matter resulting from the underlying contract.

- (2) The Contractor agrees to include the above clause in each subcontract financed in whole or in part with Federal assistance provided by FTA. It is further agreed that the clause shall not be modified, except to identify the subcontractor who will be subject to its provisions.

2.26 FEDERAL CHANGES

Contractor shall at all times comply with all applicable FTA regulations, policies, procedures and directives, including without limitation those listed directly or by reference in the Agreement (Form FTA MA (2) dated October, 1995) between RTA and FTA, as they may be amended or promulgated from time to time during the term of this contract. Contractor's failure to so comply shall constitute a material breach of this contract.

2.27 INCORPORATION OF FEDERAL TRANSIT ADMINISTRATION (FTA) TERMS

The preceding provisions include, in part, certain Standard Terms and Conditions required by DOT, whether or not expressly set forth in the preceding contract provisions. All contractual provisions required by DOT, as set forth in FTA Circular 4220.1F, are hereby incorporated by reference. Anything to the contrary herein notwithstanding, all FTA mandated terms shall be deemed to control in the event of a conflict with other provisions contained in this Agreement. The Contractor shall not perform any act, fail to perform any act, or refuse to comply with any RTA requests which would cause RTA to be in violation of the FTA terms and conditions":<https://www.transit.dot.gov/regulations-and-guidance/fta-circulars/third-party-contracting-guidance>

2.28 EXCLUSIONARY OR DISCRIMINATORY SPECIFICATIONS

Apart from inconsistent requirements imposed by federal statute or regulations, the RTA will comply with the requirements of 49 U.S.C. § 5323(h) (2) by refraining from using any Federal assistance awarded by FTA to support procurements using exclusionary or discriminatory specifications.

2.29 GEOGRAPHIC RESTRICTIONS

Except as expressly mandated, encouraged or permitted by FTA or Federal statute, RTA will refrain from using state or local geographic preferences.

2.30 PROMPT PAYMENT

Payment shall be made 30 days from date of approved and accepted invoice unless changed in the contract agreement. The prime contractor agrees to pay each subcontractor under this prime contract for satisfactory performance of its contract no later than five (5) days from the receipt of each payment the prime contractor receives from the RTA. The prime contractor further agrees to return retainage payment to each subcontractor within five (5) days after the subcontractor's work is satisfactorily completed and accepted by RTA, and all lien delay's under applicable laws have expired. Any delay or postponement of payment from the above-referenced time frame may occur only for good cause following written approval of the RTA. This clause applies to both DBE and non-DBE subcontractors.

Identification of subcontractors: All prime contractors submitting offers in response to this Request For Proposals must provide the following information for All subcontractors whether the firm is identified as a Disadvantaged Business Enterprise or not. The required information is:

- (1) Firm Name
- (2) Firm Address
- (3) Firm's status as a DBE or non DBE
- (4) The age of the firm
- (5) The annual gross receipts of the firm

Additionally, each contract RTA enters into with a contractor (and each subcontract) the prime contractor signs with a subcontractor shall include the following assurance:

The contractor, sub recipient or subcontractor shall not discriminate on the basis of race, color, national origin, or sex in the performance of this contract. The contractor shall carry out applicable requirements of 49 CFR Part 26 in the award and administration of DOT assisted contracts. Failure by the contractor to carry out these requirements is a material breach of this contract, which may result in the termination of this contract or such other remedy, as the RTA deems appropriate.

Further, each contract RTA enters into with a contractor (and each subcontract the prime contractor signs with a subcontractor shall include the following assurance:

The contractor, sub recipient or subcontractor shall make prompt payments for all satisfactory work performed under this agreement. The contractor shall within thirty (30) days of receipt of payment from RTA make all payments due subcontractors and suppliers. This requirement shall flow down to all levels including subcontractors making payments to sub subcontractors and suppliers, etc. Additionally, upon release of retainage(s) by RTA, Contractor shall in turn within thirty (30) days release retainage(s) it holds. The requirement for release of retainage(s) within thirty (30) days shall flow down to all subcontractors, etc.

performing under this contract. Contractor or any of its subcontractors, etc. may not delay or postpone payments or release of retainage without prior RTA written approval. RTA may delay, or withhold up to twenty-five percent of Contractor's payments, retainage, etc. if there is evidence that Contractor is not complying with any provision hereunder. RTA may withhold monies due Contractor until such time as Contractor by its actions or assurances has, to RTA satisfaction, proven that it will or has complied with all the requirements hereunder.

2.31 CONFIDENTIALITY

Contractor agrees that any and all information, in oral or written form, whether obtained from RTA, its agents or assigns, or other sources, or generated by Contractor pursuant to this contract shall not be used for any purpose other than fulfilling the requirements of this contract. Contractor further agrees to keep in absolute confidence all data relative to the business of RTA and RTA, their agents or assigns. No news release, including but not limited to photographs and film, public announcement, denial or confirmation of any part of the subject matter of any phase of any program hereunder shall be made by Contractor without written approval of RTA.

2.32 DISPUTES

Disputes arising in the performance of this Contract which are not resolved by agreement of the parties shall be decided in writing by the Director of Procurement. The decision of the Director of Procurement shall be final and conclusive unless within [seven (7)] days from the date of receipt of its copy, the Contractor mails or otherwise furnishes a written appeal to the Vice President-RTA. In connection with any such appeal, the Contractor may be afforded an opportunity to be heard and to offer evidence in support of its position. The decision of the Vice President-RTA shall be binding upon the Contractor and the Contractor shall abide by the decision.

Performance During Dispute. Unless otherwise directed by RTA, Contractor shall continue performance under this contract while matters in dispute are being resolved.

Claims for Damages. Should either party to the Contract suffer injury or damage to person or property because of any act or omission of the party or of any of his employees, agents or others for whose acts he is legally liable, a claim for damages therefore shall be made in writing to such other party within a reasonable time after the first observance of such injury or damage.

Remedies. Unless this contract provides otherwise, all claims, counterclaims, disputes and other matters in question between the RTA and the Contractor arising out of or relating to this agreement or its breach will be decided by arbitration if the parties mutually agree, or in a court of competent jurisdiction within the State of Louisiana.

Rights and Remedies. The duties and obligations imposed by the Contract Documents and the rights and remedies available thereunder shall be in addition to and not a limitation of any duties, obligations, rights and remedies otherwise imposed or available by law. No action or failure to act by the RTA, (its agents or assigns) or Contractor shall constitute a waiver of any right or duty afforded any of them under the Contract, nor shall any such action or failure to act constitute an approval of or acquiescence in any breach thereunder, except as may be specifically agreed in writing.

2.33 OWNERSHIP OF DOCUMENTS

Any documents, drawings, specifications, reports or data generated by the Contractor in connection with this project shall become the sole property of the RTA, subject to any rights asserted by FTA of the U.S. Department of Transportation. The Contractor may retain copies of such items for its files. The Contractor shall not release any documents, reports or data from this project without prior written permission from the RTA.

2.34 STATE AND LOCAL LAW DISCLAIMER

The use of many of the Clauses herein are not governed by federal law, many of the clauses contained herein contain FTA suggested language in certain instances these clauses may be affected by State Law.

2.35 PARTICIPANT INFORMATION FORM

All participants and their subcontractors are required to submit a completely executed, Participant Information Form available on <http://www.norta.com>.

2.36 NON-COLLUSION AFFIDAVIT

The Non-Collusion Affidavit is a required submittal. The necessary form is available on <http://www.norta.com>.

2.37 REGIONAL TRANSIT AUTHORITY GENERAL PROVISIONS

The Regional Transit Authority's General Provisions shall apply to this solicitation and resulting contract.

2.38 DISADVANTAGED BUSINESS ENTERPRISE (DBE)

It is the intent of the Regional Transit Authority (RTA) of New Orleans to create a level playing field on which Disadvantaged Business Enterprises (DBEs) can compete

fairly for opportunities. Accordingly, the RTA participates in the State-Local DBE Program of the City of New Orleans for all solicitations that are not funded by the US Department of Transportation.

DBE firms are firms which have 51% ownership and control by socially and/or economically disadvantaged individuals. For this solicitation, RTA will accept certification of DBE firms the following government agencies:

- Regional Transit Authority – SBE Certification Program
- Louisiana Department of Transportation and Development – Louisiana Unified Certification Program (LAUCP) - <http://www.laucp.org/ucp/>
- City of New Orleans Office of Supplier Diversity -- SLDBE Certification Program – www.nola.gov

In compliance with the RTA's DBE Policy to be eligible for award of a contract, the contractor/prime bidder MUST either:

1. Meet the DBE goal as advertised with meaningful DBE participation through subcontracts, joint ventures, or suppliers; OR
2. Demonstrate Good Faith Efforts to meet the DBE goal.

All firms participating on RTA projects, including SBE, SLDBE, DBE and non-DBE firms MUST be documented on the Contract Participation and DBE Commitment Form 1 – Schedule A. This form must be submitted by the prime/bidder, must include all information requested and must be signed by an authorized signatory.

For each participating SBE, SLDBE and DBE firm, a DBE Participation Questionnaire Form 2 – Schedule B MUST be included and signed by an authorized signatory of the firm. The purpose of this form is to confirm that the SBE, SLDBE or DBE firm has committed to participating on the project and that both parties agree to the scope of work and price as designated on the Contract Participation and S/DBE Commitment Form 1.

The SBE, SLDBE and DBE firms proposed on this form are binding. Any substitutions or removals of SBE, SLDBE or DBE firms listed on these forms after submission of the bid must be requested through the formal process of contract amendment and be approved by the DBE Liaison Officer. The Contractor shall, no later than three (3) days from the award of a contract, execute formal contracts, agreements and/or purchase orders with the SBE and DBE firms included on the Contract Participation and S/DBE Commitment Form 1.

If the Prime Bidder has not attained the DBE goal established for the project, Documentation of Good Faith Efforts Form 3 – Schedule C MUST be submitted. The completed form along with all required supporting documentation must be furnished. Should a bidder fail to comply with the submission of complete and accurate DBE Compliance Forms demonstrating attainment of the DBE Goal or Good Faith Efforts to attain the DBE goal, the bid shall be deemed non-responsive.

Contracting With Small and Minority Businesses, Women's Business Enterprises, and Labor Surplus Area Firms

a) Any party to this Contract, when expending any Federal funds received under this Agreement, must take all necessary affirmative steps to assure that minority businesses, women's business enterprises, and labor surplus area firms are used when possible. These steps are required for the hiring of any subcontractors under this Contract.

b) Affirmative steps must include:

- 1) Placing qualified small and minority businesses and women's business enterprises on solicitation lists;
- 2) Assuring that small and minority businesses, and women's business enterprises are solicited whenever they are potential sources;
- 3) Dividing total requirements, when economically feasible, into smaller tasks or quantities to permit maximum participation by small and minority businesses, and women's business enterprises;
- 4) Establishing delivery schedules, where the requirement permits, which encourage participation by small and minority businesses, and women's business enterprises; and
- 5) Using the services and assistance, as appropriate, of such organizations as the Small Business Administration and the Minority Business Development Agency of the Department of Commerce.

The RTA shall have the authority to investigate allegations of discriminatory practices of bidder(s) who contract or seek to contract with the RTA.

Please direct all questions related to DBE compliance prior to submission of the solicitation to the RTA Disadvantaged Business Enterprise Liaison Officer.

III. FEDERAL PROVISIONS AND REQUIREMENTS

3.1 ACCESS TO RECORDS

The following access to records requirements apply to this Contract:

- (1) RTA is a grantee of the FTA and as such in accordance with 49 C.F.R. 18.36(I), the Contractor agrees to provide the RTA, the FTA Administrator, the Comptroller General of the United States or any of their authorized representatives access to any books, documents, papers and records of the Contractor which are directly pertinent to this contract for the purposes of making audits, examinations, excerpts and transcriptions. Contractor also agrees, pursuant to 49 C.F.R. 633.17 to provide the FTA Administrator or his authorized representatives including any PMO Contractor access to Contractor's records and construction sites pertaining to a major capital project, defined at 49 U.S.C. 5302(a)1, which is receiving federal financial assistance through the programs described at 49 U.S.C. 5307, 5309 or 5311.
- (2) Where the Purchaser is a State and is the RTA or a subgrantee of RTA in accordance with 49 C.F.R. 633.17, Contractor agrees to provide the Purchaser, the FTA Administrator or his authorized representatives, including PMP Contractor, access to Contractor's records and construction sites pertaining to a major capital project, defined at 49 U.S.C. 5302(a) 1, which is receiving federal financial assistance through the programs described at 49 U.S.C. 5307, 5309 or 5311. By definition, a major capital project excludes contracts of less than the simplified acquisition threshold currently set at \$100,000.
- (3) Where the RTA enters into a negotiated contract for other than a small purchase or under the simplified acquisition threshold and is an institution of higher education, an hospital or other non-profit organization and is the FTA grantee or a subgrantee of the RTA in accordance with 49 C.F.R. 19.48, Contractor agrees to provide the RTA, FTA Administrator, the Comptroller General of the United States or any of their duly authorized representatives with access to any books, documents, papers and record of the Contractor which are directly pertinent to this contract for the purposes of making audits, examinations, excerpts and transcriptions.
- (4) Where RTA or a subgrantee of the RTA in accordance with 49 U.S. C. 5325(a) enters into a contract for a capital project or improvement (defined at 49 U.S. C. 5302(a) 1) through other than competitive bidding, the Contractor shall make available records related to the contract to the RTA, the Secretary of Transportation and the Comptroller General or any authorized officer or employee of any of them for the purposes of conducting an audit and inspection.

- (5) The Contractor agrees to permit any of the foregoing parties to reproduce by any means whatsoever or to copy excerpts and transcriptions as reasonably needed.
- (6) The Contractor agrees to maintain all books, records, accounts and reports required under this contract for a period of not less than three (3) years after the date of termination or expiration of this contract, except in the event of litigation or settlement of claims arising from the performance of this contract, in which case Contractor agrees to maintain same until the RTA, the FTA Administrator, the Comptroller General, or any of their duly authorized representatives, have disposed of all such litigation, appeals, claims or exceptions thereto. Reference 49 CFR 18.39(i) (11).

3.2 BUY AMERICA

This Contract is subject to the Federal Transit Administration Buy America Requirements in 49 CFR 660. The bidder is required to submit a signed Buy America certification with the proposal. If the bidder takes exception to the Buy America requirements a certificate of non-compliance must be signed and submitted with the proposal as it applies to the RFP request. The necessary forms are available on <http://www.norta.com>. A waiver from the Buy America Provision may be sought by the RTA if grounds for the waiver exist. Section 165(a) of the Surface Transportation Act of 1982 permits FTA participation on this contract only if steel, and manufactured products used in the contract are produced in the United States.

3.3 PRE-AWARD AND POST-DELIVERY AUDITS

Federal funds may not be obligated unless steel, iron, and manufactured products used in the projects are produced in the United States, unless FTA has granted a waiver, or the product is subject to a general waiver. 49 U.S.C. Section (5323(j)/FAST Section 3011 domestic content percentage requirement for rolling stock for fiscal years 2018-2019 must have sixty-five percent domestic content and final assembly must take place in the United States. The Buy America Requirements, CFR Part 661.11(r), define final assembly as “the creation of the end product from individual elements brought together for that purpose through application of manufacturing processes.”

3.4 CARGO PREFERENCE

The Contractor Agrees:

- a. To utilize privately owned United States-flag commercial vessels to ship at least 50 percent of the gross tonnage (computed separately for dry bulk carriers, dry cargo liners and tankers) involved, whenever shipping any equipment, materials, or commodities pursuant to this contract, to the extent such vessels are available at fair and reasonable rates for United States-flag commercial vessels;

- b. To furnish within 20 working days following the date of loading for shipments originating within the United States or within 30 working days following the date of loading for shipments originating outside the United States, a legible copy of a rated, "on-board" commercial ocean bill-of-lading in English for each shipment of cargo described in the preceding paragraph to the Division of National Cargo, Office of Market Development, Maritime Administration, Washington, D.C. 20590 and to the RTA (through the prime contractor in the case of subcontractor's bills-of-lading).
- c. To include these requirements in all subcontracts issued pursuant to this contract when the contract may involve the transportation of equipment, material or commodities by ocean vessel.

3.5 CLEAN AIR ACT AND FEDERAL WATER POLLUTION CONTROL ACT

- (1) The Contractor agrees to comply with all applicable standards, orders or regulations issued pursuant to the Clean Air Act, as amended, 42 U.S.C. §§ 7401 et seq. The Contractor agrees to report each violation to the RTA and understands and agrees that the RTA will, in turn, report each violation as required to assure notification to FTA and the appropriate EPA Regional Office.
- (2) The Contractor also agrees to include these requirements in each subcontract exceeding \$100,000 financed in whole or in part with Federal assistance provided by FTA.
- (3) The Contractor agrees to comply with applicable standards, orders or regulations issued pursuant to the Federal Water Pollution Control Act, as amended, 33 U.S.C. 1251 et seq. The Contractor agrees to report each violation to the RTA and understands and agrees that the RTA will, in turn, report each violation as required to assure notification to FTA and the appropriate EPA Regional Office.
- (4) The Contractor also agrees to include these requirements in each subcontract exceeding \$100,000 financed in whole or in part with Federal assistance provided by FTA.
- (5) **14 CFR § 1274.926 Clean Air-Water Pollution Control Acts.**
If this contract or supplement thereto is in excess of \$100,000, the Recipient agrees to notify the Agreement Officer promptly of the receipt, whether prior or subsequent to the Recipient's acceptance of this agreement, of any communication from the Director, Office of Federal Activities, Environmental Protection Agency (EPA), indicating that a

facility to be utilized under or in the performance of this agreement or any subcontract thereunder is under consideration to be listed on the EPA “List of Violating Facilities” published pursuant to 40 CFR 15.20. By acceptance of agreement in excess of \$100,000, the Recipient

(a) Stipulates that any facility to be utilized thereunder is not listed on the EPA “List of Violating Facilities” as of the date of acceptance;

(b) Agrees to comply with all requirements of section 114 of the Clean Air Act, as amended (42 U.S.C. 1857et seq. as amended by Public Law 91-604) and section 308 of the Federal Water Pollution Control Act, as amended (33 U.S.C. 1251et seq. as amended by Public Law 92-500) relating to inspection, monitoring, entry, reports and information, and all other requirements specified in the aforementioned sections, as well as all regulations and guidelines issued thereunder after award of and applicable to the contract; and

(c) Agrees to include the criteria and requirements of this clause in every subcontract hereunder in excess of \$100,000, and to take such action as the Contracting or Grant Officer may direct to enforce such criteria and requirements.

3.6 CIVIL RIGHTS ACT

The following requirements apply to the underlying contract:

(1) Nondiscrimination. In accordance with Title VI of the Civil Rights Act, as amended, 42 U.S.C. § 2000d, section 303 of the Age Discrimination Act of 1975, as amended, 42 U.S.C. § 6102, section 202 of the Americans with Disabilities Act of 1990, 42 U.S.C. § 12132, and Federal transit law at 49 U.S.C. § 5332, the Contractor agrees that it will not discriminate against any employee or applicant for employment because of race, color, creed, national origin, sex, age, or disability. In addition, the Contractor agrees to comply with applicable Federal implementing regulations and other implementing requirements FTA may issue.

(2) Equal Employment Opportunity: The following equal employment opportunity requirements apply to the underlying contract:

(a) Race, Color, Creed, National Origin, Sex. In accordance with Title VII of the Civil Rights Act, as amended, 42 U.S.C. § 2000e, and Federal transit laws at 49 U.S.C. § 5332, the Contractor agrees to comply with all applicable equal employment opportunity requirements of U. S. Department of Labor (U.S. DOL) regulations, “Office of Federal Contract Compliance Programs, Equal Employment Opportunity, Department of Labor,” 41 C.F.R. Parts 60 et seq., (which implement Executive Order No. 11246, “Equal Employment Opportunity,” as amended by Executive

Order No. 11375, “Amending Executive Order 11246 Relating to Equal Employment Opportunity,” 42 U.S. C. § 2000e note), and with any applicable Federal statutes, executive orders, regulations, and Federal policies that may in the future affect construction activities undertaken in the course of the Project. The Contractor agrees to take affirmative action to ensure that applicants are employed, and that employees are treated during employment, without regard to their race, color, creed, national origin, sex, disability or age. Such action shall include, but not be limited to, the following: employment, upgrading, demotion or transfer, recruitment or recruitment advertising, layoff or termination; rates of pay or other forms of compensation; and selection for training, including apprenticeship. In addition, the Contractor agrees to comply with any implementing requirements FTA may issue.

(b) Age. In accordance with section 4 of the Age Discrimination in Employment Act of 1967, as amended, 29 U.S.C. §§ 623 and Federal transit law at 49 U.S.C. § 5332, the Contractor agrees to refrain from discrimination against present and prospective employees for reason of age. In addition, the Contractor agrees to comply with any implementing requirements FTA may issue.

(c) Disabilities. In accordance with section 102 of the Americans with Disabilities Act, as amended, 42 U.S. C. § 12112, the Contractor agrees that it will comply with the requirements of U. S. Equal Employment Opportunity Commission, “Regulations to Implement the Equal Employment Provisions of the Americans with Disabilities Act”, 29 C.F.R. Part 1630, pertaining to employment of persons with disabilities. In addition, the Contractor agrees to comply with any implementing requirements FTA may issue.

(3) The Contractor also agrees to include these requirements in each Subcontract financed in whole or in part with Federal assistance provided by FTA, modified only if necessary to identify the affected parties.

3.7 DISADVANTAGED BUSINESS ENTERPRISE

It is the policy of the RTA to ensure that DBE’s as defined in Part 26, have an equal opportunity to participate to receive and participate in DOT-assisted contracts. It is, also, our policy –

- (i) To ensure nondiscrimination in the award and administration of DOT assisted contracts;
- (ii) To create level playing field in which DBE’s can compete fairly for DOT assisted contracts;
- (iii) To ensure that the DBE Program is narrowly tailored in accordance with applicable law;

- (iv) To ensure that only firms that fully meet 49 CFR Part 26 eligibility standards are permitted to participate as DBE's;
- (v) To help remove barriers to the participation of DBE's in DOT assisted contracts;
- (vi) To assist the development of firms that can compete successfully in the market place outside the DBE program.

CONTRACTOR ASSURANCE. The contractor, sub recipient, or subcontractor shall not discriminate on the basis of race, color, national origin, or sex in the performance of this contract. The contractor shall carry out applicable requirements of 49 CFR Part 26 in the award and administration of DOT assisted contracts. Failure by the contractor to carry out these requirements is a material breach of this contract, which may result in the termination of this contract or such other remedy, as the recipient deems appropriate.

The **NORTA Small and Disadvantaged Business Enterprise Contract Compliance System** is powered by [B2Gnow](#) Software

Reporting requirements under the SBE and DBE programs are now simplified for vendors working on RTA projects with RTA's new Small and Disadvantaged Business Enterprise Contract Compliance System. Our new web-based software system is accessible to government compliance administrators, SBE's, DBE's, contractors and the public; and includes the following key features:

- Self-managed vendor accounts with unlimited users
- Communication with contractors via email, regarding compliance issues
- Online submission of contractor and supplier monthly Program Activity Reports, with automated tracking of DBE and SBE goals
- DBE and SBE firm online verification of payments
- Flexible reporting capabilities

*All RTA contract awarded vendors are required to register contract information including their subcontractor information into the B2GNOW database.

<https://norta.dbesystem.com>

3.8 EMPLOYEE PROTECTION

Construction Activities. The Recipient agrees to comply, and assures the compliance of each subrecipient, lessee, third party contractor, and other participant at any tier of the Project, with the following Federal laws and regulations providing protections for construction employees: (1) Davis-Bacon Act, as amended, 40 U.S.C. §§ 3141 et seq., pursuant to FTA enabling legislation requiring compliance with the Davis-Bacon Act at 49 U.S.C. § 5333(a), and implementing U.S. DOL regulations, "Labor Standards Provisions Applicable to Contracts Governing Federally Financed and Assisted Construction (also Labor Standards Provisions Applicable to Nonconstruction Contracts Subject to the Contract Work Hours and Safety Standards Act)," 29 C.F.R. Part 5; (2) Contract Work Hours and Safety Standards Act, as amended, 40 U.S.C. §§ 3701 et seq., specifically, the

wage and hour requirements of section 102 of that Act at 40 U.S.C. § 3702, and implementing U.S. DOL regulations, “Labor Standards Provisions Applicable to Contracts Governing Federally Financed and Assisted Construction (also Labor Standards Provisions Applicable to Nonconstruction Contracts Subject to the Contract Work Hours and Safety Standards Act),” 29 C.F.R. Part 5; and the safety requirements of section 107 of that Act at 40 U.S.C. § 3704, and implementing U.S. DOL regulations, “Safety and Health Regulations for Construction,” 29 C.F.R. Part 1926; and (3) Copeland “Anti-Kickback” Act, as amended, 18 U.S.C. § 874 and 40 U.S.C. § 3145, and implementing U.S. DOL regulations, “Contractors and Subcontractors on Public Building or Public Work Financed in Whole or in part by Loans or Grants from the United States,” 29 C.F.R. Part 3. b. Activities Not Involving Construction. The Recipient agrees to comply, and assures the compliance of each subrecipient, lessee, third party contractor, and other participant at any tier of the Project, with the employee protection requirements for nonconstruction employees of the Contract Work Hours and Safety Standards Act, as amended, 40 U.S.C. §§ 3701 et seq., in FTA Master Agreement MA(17), 10-1-2010 58 particular with the wage and hour requirements of section 102 of that Act at 40 U.S.C. § 3702, and with implementing U.S. DOL regulations, “Labor Standards Provisions Applicable to Contracts Governing Federally Financed and Assisted Construction (also Labor Standards Provisions Applicable to Nonconstruction Contracts Subject to the Contract Work Hours and Safety Standards Act),” 29 C.F.R. Part 5. c. Activities Involving Commerce. The Recipient agrees to comply with the Fair Labor Standards Act, 29 U.S.C. §§ 201 et seq., to the extent that it applies to employees performing Project work involving commerce. d. Public Transportation Employee Protective Arrangements. If the Contract Agreement for the Project indicates that public transportation employee protective arrangements required by U.S. DOL apply to public transportation operations performed in connection with the Project, the Recipient agrees to comply with the following requirements:

(1) Standard Public Transportation Employee Protective Arrangements. To the extent that the Project involves public transportation operations and to the extent required by Federal law, the Recipient agrees to implement the Project in accordance with the terms and conditions that the U.S. Secretary of Labor has determined to be fair and equitable to protect the interests of any employees affected by the Project and that comply with the requirements of 49 U.S.C. § 5333(b), in accordance with U.S. DOL guidelines, “Section 5333(b), Federal Transit Law,” 29 C.F.R. Part 215, and any amendments thereto.

3.9 ENERGY CONSERVATION

The Contractor agrees to comply with mandatory standards and policies relating to energy efficiency which are contained in the state energy conservation plan issued in compliance with the Energy Policy and Conservation Act (42 U.S.C. 6321 et seq.).

3.10 FLY AMERICA

Contractor and all subcontractors at every tier shall comply with the requirements of 49 U.S.C. 40118 and 4 CFR Part 52. Specifically, whenever work under this agreement may involve international transportation of goods, equipment or personnel by air, only U.S. flag air carriers shall be utilized, to the extent service by these carriers is available.

Additionally, Contractor and any subcontractors at every tier shall include this requirement in all subcontracts. Further, in every instance where Contractor or any subcontractor(s) cannot comply with the requirements herein, a certification, in proper form, stating the reasons for non-compliance shall accompany the request for reimbursement or payment.

3.11 GOVERNMENT WIDE DEBARMENT AND SUSPENSION (NONPROCUREMENT)

Certification Regarding Debarment, Suspension, and other Responsibility Matters
- Lower Tier Covered Transactions (Third Party Contracts over \$100,000)

The following language and Debarment certificates (<http://www.norta.com>) must be completed and submitted as a prerequisite for consideration for award. This language and certification must also be included for all sub-contracts issued pursuant to any contract awarded hereunder.

Instructions for Certification

1. By signing and submitting this bid or proposal, the prospective lower tier participant is providing the signed certification set out below.
2. The certification in this clause is a material representation of fact upon which reliance was placed when this transaction was entered into. If it is later determined that the prospective lower tier participant knowingly rendered an erroneous certification, in addition to other remedies available to the Federal Government, RTA may pursue available remedies, including suspension and/or debarment.
3. The prospective lower tier participant shall provide immediate written notice to RTA if at any time the prospective lower tier participant learns that its certification was erroneous when submitted or has become erroneous by reason of changed circumstances.
4. The terms “covered transaction”, “debarred”, “suspended”, “ineligible”, “lower tier covered transaction”, “participant”, “persons”, “lower tier covered transaction”, “principal”, “proposal”, and “voluntarily excluded”, as used in this clause, have meanings set out in the Definitions and Coverage sections of rules implementing Executive Order 12549 [49 CFR Part 29].
5. The prospective lower tier participant agrees by submitting this proposal that, should the proposed covered transaction be entered into, it shall not knowingly enter into any lower tier covered transaction with a person who is debarred, suspended, declared ineligible, or voluntarily excluded from participation in this covered transaction, unless authorized in writing by RTA.

6. The prospective lower tier participant further agrees by submitting this proposal that it will include the clause titled “Certification Regarding Debarment, Suspension, Ineligibility and Voluntary Exclusion - Lower Tier Covered Transaction”, without modification, in all lower tier covered transactions and in all solicitation for lower tier covered transaction.
7. A participant in a covered transaction may rely upon a certification of a prospective participant in a lower tier covered transaction that it is not debarred, suspended, ineligible, or voluntarily excluded from the covered transaction, unless it knows that the certification is erroneous. A participant may decide the method and frequency by which determines the eligibility of its principals. Each participant may, but is not required to, check the Non-procurement List issued by U.S. General Service Administration.
8. Nothing contained in the foregoing shall be construed to require establishment of system of records in order to render in good faith the certification required by this clause. The knowledge and information of a participant is not required to exceed that which is normally possessed by a prudent person in the ordinary course of business dealings.
9. Except for transactions authorized under Paragraph 5 of these instructions, if a participant in a covered transaction knowingly enters into a lower tier covered transaction with a person who is suspended, debarred, ineligible, or voluntarily excluded from participation in this transaction, in addition to all remedies available to the Federal Government, RTA may pursue available remedies including suspension and/or Debarment.

3.12 RESTRICTIONS ON LOBBYING

Byrd Anti-Lobbying Amendment, 31 U.S.C. 1352, as amended by the Lobbying Disclosure Act of 1995, P.L. 104-65 [to be codified at 2 U.S.C. § 1601, et seq.] Contractors who apply or bid for an award of \$100,000 or more shall file the certification required by 49 CFR parts 20, “New Restrictions on Lobbying.” Each tier certifies to the tier above that it will not and has not used Federal appropriated funds to pay any person or organization for influencing or attempting to influence an officer or employee of any agency, a member of Congress, officer or employee of Congress, or an employee of a member of Congress in connection with obtaining any Federal contract, grant or any other award covered by 31 U.S.C. 1352. Each tier shall also disclose the name of any registrant under the Lobbying Disclosure Act of 1995 who has made lobbying contacts on its behalf with non-Federal funds with respect to that Federal contract, grant or award covered by 31 U.S.C. 1352. Such disclosures are forwarded from tier to tier up to the RTA. The necessary form is available on <http://www.norta.com>.

3.13 NO FEDERAL GOVERNMENT OBLIGATIONS TO THIRD PARTIES

The federal government shall not be subject to any obligations or liabilities to any third-party Contractor, or any other person not a party to the Grant Agreement or Cooperative Agreement in connection with the performance of this contract. Notwithstanding any concurrence provided by the federal government in or approval of any solicitation, subagreement, or third-party contract, the federal government continues to have no obligations or liabilities to any party, including the third-party Contractor.

3.14 PATENT AND RIGHTS IN DATA

These following requirements apply to each contract involving experimental, developmental or research work: 1. The term "subject data" used in this clause means recorded information, whether or not copyrighted, that is delivered or specified to be delivered under the contract. The term includes graphic or pictorial delineation in media such as drawings or photographs; text in specifications or related performance or design-type documents; machine forms such as punched cards, magnetic tape, or computer memory printouts; and information retained in computer memory. Examples include, but are not limited to: computer software, engineering drawings and associated lists, specifications, standards, process sheets, manuals, technical reports, catalog item identifications, and related information. The term "subject data" does not include financial reports, cost analyses, and similar information incidental to contract administration. 2. The following restrictions apply to all subject data first produced in the performance of the contract to which this Attachment has been added: a. Except for its own internal use, the Contractor may not publish or reproduce subject data in whole or in part, or in any manner or form, nor may the Contractor authorize others to do so, without the written consent of the Federal Government, until such time as the Federal Government may have either released or approved the release of such data to the public; this restriction on publication, however, does not apply to any contract with an academic institution. b. In accordance with 49 C.F.R. § 18.34 and 49 C.F.R. § 19.36, the Federal Government reserves a royalty-free, non-exclusive and irrevocable license to reproduce, publish, or otherwise use, and to authorize others to use, for "Federal Government purposes," any subject data or copyright described in subsections (2)(b)1 and (2)(b)2 of this clause below. As used in the previous sentence, "for Federal Government purposes," means use only for the direct purposes of the Federal Government. Without the copyright owner's consent, the Federal Government may not extend its Federal license to any other party. (1). Any subject data developed under that contract, whether or not a copyright has been obtained; and (2). Any rights of copyright purchased by the Contractor using Federal assistance in whole or in part provided by FTA. c. When FTA awards Federal assistance for experimental, developmental, or research work, it is FTA's general intention to increase transportation knowledge available to the public, rather than to restrict the benefits resulting from the work to participants in that work. Therefore, unless FTA determines otherwise, the Contractor performing experimental, developmental, or research work required by the underlying contract to which this Attachment is added agrees to permit FTA to make available to the public, either FTA's license in the copyright to any subject data developed in the course of that contract, or a copy of the subject data first produced under the contract for which a copyright has

not been obtained. If the experimental, developmental, or research work, which is the subject of the underlying contract, is not completed for any reason whatsoever, all data developed under that contract shall become subject data as defined in subsection (a) of this clause and shall be delivered as the Federal Government may direct. This subsection (c), however, does not apply to adaptations of automatic data processing equipment or programs for the Contractor's use whose costs are financed in whole or in part with Federal assistance provided by FTA for transportation capital projects. d. Unless prohibited by state law, upon request by the Federal Government, the Contractor agree to indemnify, save, and hold harmless the Federal Government, its officers, agents, and employees acting within the scope of their official duties against any liability, including costs and expenses, resulting from any willful or intentional violation by the Contractor of proprietary rights, copyrights, or right of privacy, arising out of the publication, translation, reproduction, delivery, use, or disposition of any data furnished under that contract. Contractor shall not be required to indemnify the Federal Government for any such liability arising out of the wrongful act of any employee, official, or agents of the Federal Government. e. Nothing contained in this clause on rights in data shall imply a license to the Federal Government under any patent or be construed as affecting the scope of any license or other right otherwise granted to the Federal Government under any patent. f. Data developed by Contractor and financed entirely without using Federal assistance provided by the Federal Government that has been incorporated into work required by the underlying contract to which this Attachment has been added is exempt from the requirements of subsections (b), (c), and (d) of this clause, provided that the Contractor identifies that data in writing at the time of delivery of the contract work. g. Unless FTA determines otherwise, the Contractor agrees to include these requirements in each subcontract for experimental, developmental, or research work financed in whole or in part with Federal assistance provided by FTA. 3. Unless the Federal Government later makes a contrary determination in writing, irrespective of the Contractor's status (i.e., a large business, small business, state government or state instrumentality, local government, nonprofit organization, institution of higher education, individual, etc.), Contractor agrees to take the necessary actions to provide, through FTA, those rights in that invention due the Federal Government as described in U.S. Department of Commerce regulations, "Rights to Inventions Made by Nonprofit Organizations and Small Business Firms Under Government Grants, Contracts and Cooperative Agreements," 37 C.F.R. Part 401. 4. The Contractor also agrees to include these requirements in each subcontract for experimental, developmental, or research work financed in whole or in part with Federal assistance provided by FTA.

3.15 PROGRAM FRAUD AND FALSE OR FRAUDULENT STATEMENTS AND RELATED ACTS UPPER AND LOWER TIER TRANSACTIONS

- (1) The Contractor acknowledges that the provisions of the Program Fraud Civil Remedies Act of 1986, as amended, 31 U.S.C. §§3801 et. seq. and U.S. DOT regulations, "Program Fraud Civil Remedies", 49 C.F.R. Part 31, apply to its actions pertaining to this Project. Upon execution of the underlying contract, the Contractor certifies or affirms the truthfulness and accuracy of any statement it has made, it makes, it may make, or causes to be made,

pertaining to the underlying contract or the FTA assisted project for which this contract work is being performed. In addition to other penalties that may be applicable, the Contractor further acknowledges that if it makes, or causes to be made, a false, fictitious, or fraudulent claim, statement, submission, or certification, the Federal Government reserves the right to impose the penalties of the Program Fraud Civil Remedies Act of 1986 on the Contractor to the extent the Federal Government deems appropriate.

- (2) The Contractor also acknowledges that if it makes, or causes to be made, a false, fictitious, or fraudulent claim, statement, submission, or certification to the Federal Government under a contract connected with a project that is financed in whole or in part with Federal assistance originally awarded by FTA under the authority of 49 U.S. C. §5307, the Government reserves the right to impose the penalties of 18 U.S.C. §1001 and 49 U.S.C. §5307(n)(1) on the Contractor, to the extent the Federal Government deems appropriate.
- (3) The Contractor agrees to include the above two clauses in each subcontract financed in whole or in part with Federal assistance provided by FTA. It is further agreed that the clauses shall not be modified, except to identify the subcontractor who will be subject to the provisions.

3.16 RECYCLED PRODUCTS

Recovered Materials. The contractor agrees to comply with all the requirements of Section 6002 of the Resource Conservation and Recovery Act (RCRA), as amended (42 U.S.C. 6962), including but not limited to the regulatory provisions of 40 CFR Part 247, and Executive Order 12873, as they apply to the procurement of the items designated in Subpart B of 40 CFR Part 247.

3.17 SAFE OPERATION OF MOTOR VEHICLE

The Recipient agrees as follows: a. Seat Belt Use. In accordance with the provisions of Executive Order No. 13043, "Increasing Seat Belt Use in the United States," April 16, 1997, 23 U.S.C. § 402 note, the Recipient is encouraged to adopt and promote on-the-job seat belt use policies and programs for its employees and other personnel that operate company-owned, rented, or personally operated vehicles, and to include this provision in any subagreements, leases, third party contracts, or other similar documents in connection with the Project. b. Distracted Driving, Including Text Messaging While Driving. In accordance with Executive Order No. 13513, "Federal Leadership on Reducing Text Messaging While Driving," October 1, 2009, and DOT Order 3902.10, "Text Messaging While Driving," December 30, 2009, the Recipient is encouraged to comply with the terms of the following Special Provision: (1) Definitions. As used in this Special Provision: (a) "Driving" means operating a motor vehicle on a roadway, including while temporarily stationary because of traffic, a traffic light, stop sign, or otherwise. "Driving" does not include being in your vehicle (with or without the motor running) in a location off the roadway where it is safe and legal to remain

stationary. (b) “Text Messaging” means reading from or entering data into any handheld or other electronic device, including for the purpose of short message service texting, e-mailing, instant messaging, obtaining navigational information, or engaging in any other form of electronic data retrieval or electronic data communication. The term does not include the use of a cell phone or other electronic device for the limited purpose of entering a telephone number to make an outgoing call or answer an incoming call, unless the practice is prohibited by State or local law. (2) Safety. The Recipient is encouraged to: (a) Adopt and enforce workplace safety policies to decrease crashes caused by distracted drivers including policies to ban text messaging while driving— (b) Recipient-owned or Recipient-rented vehicles or Government-owned, leased or rented vehicles; (c) Privately-owned vehicles when on official Project related business or when performing any work for or on behalf of the Project; or (d) Any vehicle, on or off duty, and using an employer supplied electronic device. (3) Recipient Size. The Recipient is encouraged to conduct workplace safety initiatives in a manner commensurate with the Recipient’s size, such as: (a) Establishment of new rules and programs or re-evaluation of existing programs to prohibit text messaging while driving; and (b) Education, awareness, and other outreach to employees about the safety risks associated with texting while driving. (4) Extension of Provision. The Recipient is encouraged to include this Special Provision in its subagreements with its subrecipients, its leases, and its third party contracts, and also encourage its subrecipients, lessees, and third party contractors to comply with the terms of this Special Provision, and include this Special Condition in each subagreement, lease, and third party contract at each tier financed with Federal assistance provided by the Federal Government.

3.18 SUBSTANCE ABUSE REQUIREMENTS

To the extent applicable, the Recipient agrees to comply with the following Federal regulations and guidance: a. Drug-Free Workplace. U.S. OMB guidance, “Governmentwide Requirements for Drug-Free Workplace (Financial Assistance),” 2 C.F.R. Part 182, and U.S. DOT regulations, “Governmentwide Requirements for Drug-Free Workplace (Financial Assistance),” 49 C.F.R. Part 32, that implement the Drug-Free Workplace Act of 1988, as amended, 41 U.S.C. §§ 702 et seq., including any amendments to these U.S. DOT regulations when they are promulgated. b. Alcohol Misuse and Prohibited Drug Use. FTA regulations, “Prevention of Alcohol Misuse and Prohibited Drug Use in Transit Operations,” 49 C.F.R. Part 655, that implement 49 U.S.C. § 5331.

3.19 TERMINATION

a. Termination for Convenience (General Provision) The RTA may terminate this contract, in whole or in part, at any time by written notice to the Contractor when it is in the RTA’s and/or the Government’s best interest. The Contractor shall be paid its costs, including contract closeout costs, and profit on work performed up to the time of termination. The Contractor shall promptly submit its termination claim to RTA to be paid the Contractor. If the Contractor has any property in its possession belonging to the RTA, the Contractor will account for the same, and dispose of it in the manner the RTA directs.

b. Termination for Default [Breach or Cause] (General Provision) If the Contractor does not deliver supplies in accordance with the contract delivery schedule, or, if the contract is for services, the Contractor fails to perform in the manner called for in the contract, or if the Contractor fails to comply with any other provisions of the contract, the RTA may terminate this contract for default. Termination shall be affected by serving a notice of termination on the contractor setting forth the manner in which the Contractor is in default. The contractor will only be paid the contract price for supplies delivered and accepted, or services performed in accordance with the manner of performance set forth in the contract. If it is later determined by the RTA that the Contractor had an excusable reason for not performing, such as a strike, fire, or flood, events which are not the fault of or are beyond the control of the Contractor, the RTA, after setting up a new delivery or performance schedule, may allow the Contractor to continue work, or treat the termination as a termination for convenience.

c. Opportunity to Cure (General Provision) The RTA in its sole discretion may, in the case of a termination for breach or default, allow the Contractor [an appropriately short period of time] in which to cure the defect. In such case, the notice of termination will state the time period in which cure is permitted and other appropriate conditions. If Contractor fails to remedy to RTA's satisfaction the breach or default or any of the terms, covenants, or conditions of this Contract within [ten (10) days] after receipt by Contractor of written notice from RTA setting forth the nature of said breach or default, (RTA) shall have the right to terminate the Contract without any further obligation to Contractor. Any such termination for default shall not in any way operate to preclude (RTA) from also pursuing all available remedies against Contractor and its sureties for said breach or default.

d. Waiver of Remedies for any Breach. In the event that RTA elects to waive its remedies for any breach by Contractor of any covenant, term or condition of this Contract, such waiver by RTA shall not limit RTA's remedies for any succeeding breach of that or of any other term, covenant, or condition of this Contract.

3.20 CONTRACT WORK HOURS AND SAFETY STANDARD ACT

The Contract Work Hours and Safety Standards Act is codified at 40 USC 3701, et seq. The Act applies to grantee contracts and subcontracts "financed at least in part by loans or grants from ... the [Federal] Government." 40 USC 3701(b) (1) (B) (iii) and (b) (2), 29 CFR 5.2(h), 49 CFR 18.36(i) (6). The Act applies to construction contracts and, in very limited circumstances, non-construction projects that employ "laborers or mechanics on a public work" with a value greater than \$100,000. These nonconstruction applications do not generally apply to transit procurements because transit procurements (to include rail cars and buses) are deemed "commercial items." 40 USC 3707, 41 USC 403 (12) Flow down Requirements: Applies to third party contractors and sub-contractors. (1) Overtime requirements - No contractor or sub-contractor contracting for any part of the contract work which may require or involve the employment of laborers or mechanics shall require or permit any such laborer or mechanic in any workweek in which he or she is employed on such work to work in excess of forty (40) hours in such workweek unless such laborer or mechanic receives compensation at a rate not less than one and one-half

(1.5) times the basic rate of pay for all hours worked in excess of forty (40) hours in such workweek. (2) Violation; liability for unpaid wages; liquidated damages - In the event of any violation of the clause set forth in paragraph (1) of this section the contractor and any sub-contractor responsible therefor shall be liable for the unpaid wages. In addition, such contractor and sub-contractor shall be liable to the United States for liquidated damages. Such liquidated damages shall be computed with respect to each individual laborer or mechanic, including watchmen and guards, employed in violation of the clause set forth in paragraph (1) of this section, in the sum of \$10 for each calendar day on which such individual was required or permitted to work in excess of the standard workweek of forty (40) hours without payment of the overtime wages required by the clause set forth in paragraph (1) of this section. (3) Withholding for unpaid wages and liquidated damages - NCTD shall upon its own action or upon written request of an authorized representative of the Department of Labor withhold or cause to be withheld, from any moneys payable on account of work performed by the contractor or sub-contractor under any such contract or any other Federal contract with the same prime contractor, or any other federally-assisted contract subject to the Contract Work Hours and Safety Standards Act, which is held by the same prime contractor, such sums as may be determined to be necessary to satisfy any liabilities of such contractor or sub-contractor for unpaid wages and liquidated damages as provided in the clause set forth in paragraph (2) of this section. (4) Subcontracts - The Contractor or sub-contractor shall insert in any subcontracts the clauses set forth in paragraphs (1) through (4) of this section and also a clause requiring the sub-contractors to include these clauses in any lower tier subcontracts. The prime contractor shall be responsible for compliance by any sub-contractor or lower tier sub-contractor with the clauses set forth in paragraphs (1) through (4) of this section.

IV. EVALUATION CRITERIA

4.1 ADMINISTRATIVE EVALUATION

Prior to the distribution of submittals to the Technical Evaluation Committee, the RTA shall perform an administrative evaluation of each submittal to determine completeness and responsiveness to this RFP.

4.2 EVALUATION CRITERIA

The following evaluation criteria will be used by the Technical Evaluation Committee. The criteria and the weighted values (in parentheses) to be used by the Technical Evaluation Committee in evaluating responses for the selection of a firm(s) to perform this service(s) are listed below:

1. (35) Overall Qualifications - Capability, professional competence and character of the team, including relevant experience as an insurance broker of record for a public transit agency or similar public entity.
2. (40) Technical Qualifications - Suitability of the firm's approach to meet the needs and criteria set forth in the Scope of Work, including:
 - a) Ability to market, solicit, place and administer property, casualty and related insurance coverages, e.g. crime, overhead catenary ("OCS"), public officials/public entity errors and omissions ("E&O"), flood, parametric, excess workers' compensation, cyber liability, automobile liability, general liability, and automobile physical damage ("APD"). These coverages shall pertain to a transit property or similar public entity operating bus, streetcar and paratransit vehicles.
 - b) Ability to market, solicit, place and administer medical, dental, vision, and life insurance coverages.
 - c) Demonstration of knowledge and experience in working with relevant insurance carriers and underwriters in the insurance arena. This knowledge and experience shall pertain to a transit property or similar public entity operating bus, streetcar and paratransit vehicles.
3. (5) References - Prior experience and results on similar projects.
4. (5) Firm's current client base and workload.
5. (5) Accessibility of those assigned to the project to meet with RTA staff.
6. (10) Price.

4.3 CONTRACT AWARD

(1) The RTA intends to award a contract or contracts resulting from this solicitation to the responsible offeror(s) whose proposal(s) represents the best value after evaluation in accordance with the factors and sub-factors in the solicitation.

(2) The RTA may reject any or all proposals if such action is in the RTA's interest.

(3) The RTA may waive informalities and minor irregularities in proposals received.

(4) The RTA intends to evaluate proposals and award contracts without discussions with offerors. Therefore, the offeror's initial proposal should contain the offeror's best terms from a cost or price and technical standpoint. The RTA reserves the right to conduct discussions if the Contracting Officer later determines them to be necessary. If the Contracting Officer determines that the number of proposals that would otherwise be in the competitive range exceeds the number at which an efficient competition can be conducted, the Contracting Officer may limit the number of proposals in the competitive range to the greatest number that will permit an efficient competition among the most highly rated proposals.

(5) The RTA reserves the right to make an award on any item for a quantity less than the quantity offered, at the unit cost or prices offered, unless the offeror specifies otherwise in the proposal.

(6) The RTA reserves the right to make multiple awards if, after considering the additional administrative costs, it is in the RTA's best interest to do so.

(7) Exchanges with offerors after receipt of a proposal do not constitute a rejection or counteroffer by the RTA.

(8) The RTA may determine that a proposal is unacceptable if the prices proposed are materially unbalanced between line items or subline items. Unbalanced pricing exists when, despite an acceptable total evaluated price, the price of one or more line items is significantly overstated or understated as indicated by the application of cost or price analysis techniques. A proposal may be rejected if the Contracting Officer determines that the lack of balance poses an unacceptable risk to the RTA.

(9) If a cost realism analysis is performed, cost realism may be considered by the source selection authority in evaluating performance or schedule risk.

(10) A written award or acceptance of proposal mailed or otherwise furnished to the successful offeror within the time specified in the proposal shall result in a binding contract without further action by either party.

(11) If a post-award debriefing is given to requesting offerors, the RTA shall disclose the following information, if applicable:

(i) The agency's evaluation of the significant weak or deficient factors in the debriefed offeror's offer.

(ii) The overall evaluated cost or price and technical rating of the successful and the debriefed offeror and past performance information on the debriefed offeror.

(iii) The overall ranking of all offerors, when any ranking was developed by the agency during source selection.

(iv) A summary of the rationale for award.

(v) For acquisitions of commercial items, the make and model of the item to be delivered by the successful offeror.

(vi) Reasonable responses to relevant questions posed by the debriefed offeror as to whether source-selection procedures set forth in the solicitation, applicable regulations, and other applicable authorities were followed by the agency.

RTA shall score and rank all proposals based upon the evaluation criteria contained herein. An interview and/or presentation may be required. Award of this contract shall be to a properly licensed, responsible offeror deemed the most qualified, for which fair and reasonable compensation can be determined.

Proposers are reminded that price/cost shall not be used as an evaluation factor during the initial evaluation. However, price proposals will be evaluated and proposers are required to submit cost data separately with their proposal. Proposals which do not contain cost/price information may be considered non-responsive to the administrative requirements of the RFP.

PROPOSAL PRICING RESTRICTIONS

Any proposed overhead rate which exceeds 75% of approved categories (e.g., “labor”) shall be substantiated by a current audit performed by an independent Certified Public Accounting Firm. Any proposed overhead rate which exceeds 100% of the approved categories shall be substantiated by a current audit conducted by a federal or state agency. Labor rates for all individuals who may perform any work associated with this project shall be identified in the proposal. The individuals will be identified by name and job category. This requirement extends to all individuals whether classified as professional or non-professional. Any changes in labor rates and/or additions or changes to personnel providing work on this project must be pre-approved by RTA in writing.

4.4 OVERHEAD RATES

Contractor will be required to submit an audited overhead rate.

4.5 PLACE OF PERFORMANCE

(a) The offeror or respondent, in the performance of any contract resulting from this solicitation, _____ **intends**, _____ **does not intend** [**check applicable block**] to use one or more plants or facilities located at a different address from the address of the offeror or respondent as indicated in this proposal or response to request for information.

(b) If the offeror or respondent checks “intends” in paragraph (a) of this provision, it shall insert in the following spaces the required information:

Place of Performance (Street
Address, City, State, County, ZIP
Code)

Name and Address of Owner and Operator of the
Plant or Facility if Other than Offeror or
Respondent

ATTACHMENT I
SUPPLIER SUBMISSION CHECKLIST

The following items must be submitted as noted in order to be considered responsive.

Letter of Interest*

Consultant Questionnaire Form*

Non-Collusion Affidavit*

Certificate on Primary Debarment *

Certificate Regarding Debarment– Lower Tier *

Certification of Restrictions on Lobbying *

Participant Information Form*

DBE Form 4 – DBE Participation Plan (For RFPs and RFQs)*

To be determine responsive all forms are due on the proposal submittal date.

INSTRUCTIONS FOR OBTAINING FORMS

Go to RTA’s official web site at:

[New Orleans Regional Transit Authority - Procurements and Contracts \(norta.com\)](http://www.norta.com)

Click on “Vendor Form Library”

REGIONAL TRANSIT AUTHORITY

PUBLIC NOTICE

RFP 2025-007- INSURANCE BROKERAGE SERVICES

Addendum I

Acknowledge receipt of this addendum in the bid submission. This addendum is a part of the Contract Documents and shall be included in the Contract Documents. Changes made by the addenda take precedence over information published at an earlier date.

Request For Proposal No. 2024-024 has been amended as follows:

Should our Cost for Services be provided as a separate document or included within our response? **Include in response**

1. **Is there a particular form that we should use to show our cost for services? **no****
2. **Is the DBE Form 4 required since there is no DBE goal? **Yes****
3. **Item 1.1 states that we are required to "include a Letter of Interest that addresses the suggested structure or organization of the proposed team, a detailed description of your team's approach and capability to handle project specific issues a schedule of the proposed work, and any other information that may assist the RTA in making a selection. Letters of Interest should be concise and limited to three (3) pages." My question: are we being asked to respond to the RFP by including a three page Letter of Interest which outlines our capabilities and the required forms shown in Attachment I : Supplier Submission Checklist? The letter of interest does not have to be 3 pages. **Capabilities and etc. should be apart of your proposal. The supplier checklist is located at the end of the solicitation****
4. **To clarify question 4 previously sent on 1/17/25. My question is this. Should our response be limited to the 3 pages in our Letter of Interest and the required forms outlined in Attachment I? Also, please confirm that our Cost Proposal should be submitted at the same time as our Response but as a separate document. Thank you. **No proposal is not limited to 3 pages. Yes cost proposal should be submitted at the same time along with the proposal.****
5. **Are there specific questions that need to be addressed, or should the response be based on the Scope of Services? **You should look over the evaluation criteria located in the solicitation along with the scope of work.****

6. The Scope of Services document outlines traditional brokerage services for Medical, Dental, Vision, and Life Insurance. Is RTA seeking services for both retired and full-time employees? **No-Retirees Only**
7. Do you plan to provide any answers or data related to the current health plan? **No**
8. According to section 4.2 Evaluation Criteria, it seems that most of the evaluation will focus on Overall Qualifications and Technical Qualifications. Should these items be addressed within the 3-page limit of the Letter of Interest, or are they exempt from the page limit? **No, they should be addressed in the proposal which is NOT limited to 3 pages.**
9. The RFP requests proposal for both Property and Casualty Services and Employees Benefits Services. To qualify for either, must an agency present proposals for both? **Yes**
10. Can an agency submit separate property & casualty and employee benefits proposals, or must they be submitted together? **Submit together**
11. Should our DBE partner be registered as a separate bidder on the RFP portal? **No**
12. Does the RTA have a benefit program for active employees? **Yes** The “Scope of Services only mentions former employees, retirees, and their dependents. If the RTA does provide benefit programs for active employees, is that not included in services that you are seeking in this RFP? **No-Only Retirees**
13. If the RTA has benefit programs for active employees, is this separate from the Health, Dental, Vision, and Life programs that the retirees are eligible for? **Yes**
14. When retirees age into Medicare, are they being transitioned into an individual Medicare option or do you currently have a group Medicare Advantage plan established specifically for these retirees? **Transitioned**

REGIONAL TRANSIT AUTHORITY

PUBLIC NOTICE

RFP 2025-007- INSURANCE BROKERAGE SERVICES

Addendum II

Acknowledge receipt of this addendum in the bid submission. This addendum is a part of the Contract Documents and shall be included in the Contract Documents. Changes made by the addenda take precedence over information published at an earlier date.

Request For Proposal No. 2024-024 has been amended as follows:

The due date for proposals will be next Wednesday, February 19, 2025, at 4 PM in lieu of the current date of Friday, February 14, 2025, 4PM. Clarification date will not be extended.

Please see attachment labeled “Revised Scope of Work” removing all reference to Employee Retiree Benefits. New scope solely addresses and relate to Property and Casualty Services.

**Lona Hankins
Chief Executive Officer**



Relationships Matter.

PROPOSAL

presented to

Regional Transit Authority

RFP #2025-007 | Insurance Brokerage Services
February 19, 2025



CONFIDENTIAL INFORMATION

The information furnished to you in this response is confidential and proprietary in nature. Relation Insurance Services (Relation) is providing this information with the understanding that Regional Transit Authority (RTA) and any of RTA's consultants or third parties will use it solely for purposes of evaluating whether to enter into the specific proposed business relationship with Relation for which this information is provided. The information shall not be used for any other purpose by RTA, any of RTA's consultants or third parties. By accepting this information, RTA further agrees not to disclose it to anyone other than officers or employees of RTA and its representatives and consultants who are directly involved in the evaluation process.

CONTENTS

01	LETTER OF INTEREST
04	METHODOLOGY & APPROACH
05	ADDITIONAL SERVICES OFFERED
06	FIRM'S FINANCIAL & COMPLIANCE STANDING
07	TIMELINE
09	PROJECT STAFF
11	PROJECT ORGANIZATIONAL CHART
12	CONSULTANT QUESTIONNAIRE FORM
20	NON-COLLUSION AFFIDAVIT
21	CERTIFICATE ON PRIMARY DEBARMENT
22	CERTIFICATE REGARDING DEBARMENT - LOWER TIER
23	CERTIFICATION OF RESTRICTIONS ON LOBBYING
24	PARTICIPANT INFORMATION FORM
25	DBE FORM 4 - DBE PARTICIPATION PLAN
28	ACKNOWLEDGEMENT OF ADDENDA
29	COST PROPOSAL

935 Gravier St, Ste 1350
New Orleans, LA 70112
office (504) 558-9390
LA License #526540

February 19, 2025

Ms. Lona Hankins
Chief Executive Officer
New Orleans Regional Transit Authority
2817 Canal St
New Orleans, LA 70119

RE: RFP #2025-007 | Insurance Brokerage Services

Dear Ms. Hankins:

On behalf of Relation Insurance Services, I am pleased to present our response to the Regional Transit Authority (RTA) Request for Proposal #2025-007 Insurance Brokerage Services.

Relation Insurance Services is a leading independent insurance brokerage offering risk management and benefits consulting services, as well as administrative services, across a broad range of industries. We offer a diversified portfolio of insurance solutions across property & casualty, employee benefits, and captive management. We currently employ over 1,250 employees in 135 offices across the U.S. and in 2024 we were ranked 23rd on Insurance Journal's "Top 100 Independent Property/Casualty Agencies" [in the U.S.] report.

We are committed to helping our clients navigate their myriad insurance needs by building relationships and leveraging the right mix of people, partnerships, processes, and technologies. With the capabilities and resources of a national company, we deliver results. But it is the trust comes-first mindset of a local partner that lets us deliver those results in a way that is both comfortable and friendly. We are a partner on whom you can rely. A friend you can call. And we are here for the long-haul by your side.

Our Core Values serve as the guiding principles for our organization. These principles and standards shape our culture, define our brand, and influence our business strategies. When we emphasize the significance of Relationships Matter, these values elucidate our commitment.

- **Accountability.** We fulfill our promises and proactively communicate if any commitment cannot be met.
- **Trust.** We foster openness, honesty, and transparency in communication, both within our team and with our valued customers.
- **Growth.** We dedicate ourselves to continuous improvement, enhancing both our individual capabilities and the solutions we provide. Through ongoing learning, we apply newfound knowledge to elevate our performance.
- **Communication.** We actively listen, process information, learn, and share knowledge to propel each initiative towards success.

Relation's mission is to provide customized solutions to our clients. We believe that each client is unique and have found that the most effective way to collaborate with our clients is through a true partnership. We will always strive to exceed your expectations. This includes not only providing these services outlined in this proposal but also being proactive in bringing innovative ideas that may be relevant to your organization. You will have a dedicated team who will perform the following tasks:

RISK IDENTIFICATION & ANALYSIS

It is critical we gain a thorough understanding of the unique blend of your operations, exposures, and attitudes toward risk. We start with a comprehensive review typically including the following:

- Physical inspections
- Deep-dive interviews with senior leadership and key operational staff
- An analysis of historical losses and claim trends, which can impact placement results (where there is sufficient data, we complete statistical loss projections)
- A review of existing insurance policies and insurance program financial structures
- A review of any current risk-control and loss-prevention initiatives

Upon renewals for existing clients, we repeat many of these steps to track operational changes, monitor current insurance-program performance, and ensure our unwavering understanding of the organization.

PROGRAM DESIGN, NEGOTIATION, AND PLACEMENT

Strategic Planning:

With risk-identification and analysis information in hand, we then begin the insurance-placement process with a strategic planning session where we:

- Discuss potential risk-treatment techniques that may include a blend of avoidance, retention, and/or risk transfer either through insurance or contract
- Review the scope and structure of existing insurance programs to help ensure coverage, retentions/deductible, and limits are appropriate, and decide if any adjustments should be made
- Evaluate the state of the insurance marketplace and determine whether to market competitively or to renew with existing carriers

Program Marketing:

- **Carrier Selection.** The insurance market is dynamic, and we devote tremendous time and energy to stay current on insurer capabilities and underwriting appetites. Our understanding of the markets, coupled with our significant premium volume, puts us in a position of strength to carefully match you with suitable insurers and use our negotiating leverage.
- **Underwriting Submission.** Before approaching the market(s), we invest time to ensure we create a quality submission that accurately represents your operations, exposures, risks, loss-prevention activities, and our renewal expectations of the markets, including coverages, structure options, and pricing.
- **Negotiation.** We work with underwriters to push for the most advantageous options for you. We avoid surprises and work to keep you apprised of our negotiation progress.

- **Renewal Presentation.** We prepare detailed comparisons of coverage terms and conditions, program financial factors (e.g., premiums, retentions, deductible, limits, etc.) and, if appropriate, alternative program structures. We review advantages and disadvantages of each alternative and make recommendations. Placement and Ongoing Monitoring: Once we implement the program, we continue to monitor its performance throughout the year, assess how well it works, and make modifications if necessary.
- **Placement and Ongoing Monitoring.** Once we implement the program, we continue to monitor its performance throughout the year, assess how well it works, and make modifications if necessary.

POST PLACEMENT DAY-TO-DAY ADMINISTRATION

As a true partner, we recognize our ongoing obligation to provide support 365 days a year. In order to ensure programs are running smoothly, we can:

- Deliver binding confirmation documentation
- Handle all accounting matters
- Create schedules of insurance
- See that policies are issued, checked for accuracy, and delivered as quickly as possible
- Make policy modifications as changing circumstances require during the year
- Promptly issue certificates of insurance and vehicle ID cards
- Review insurance-related provisions in contracts and agreements
- Keep you informed of relevant insurance marketplace, legal, or legislative issues or developments

My staff and I have been working with the RTA as your insurance broker and partner for over 15 years. We have worked diligently to maintain insurance coverages and contain costs under exceedingly difficult and often trying situations. We have always come through for the RTA. We hope that the evaluation committee will allow us to continue our excellent work and our partnership for the next three years.

Please do not hesitate to contact me at **(504) 558-9391** (o), **(504) 481-8962** (c) or rick.grubb@relationinsurance.com if you have any questions or require additional information.

Best Regards,

Broderick C. Grubb

Broderick C. Grubb

VICE PRESIDENT

OUR PROCESS



BUSINESS SOLUTIONS

- **Dedicated Team Members.** Full-service team with back-up members to ensure no gaps in service.
- **Benefit Cost & Analysis.** Sharing information about changes in the insurance marketplace, or new coverages and policies to consider.
- **Procurement & Renewals.** Marketing with the goal of competitive programs with needed coverages, along with analysis of coverages to help make the best decisions for your employees.
- **Document Requests.** Immediate response to certificate requests and coverage questions, and timely review of policies and preparation of a Summary of Benefits.
- **Safety Training.** Safety training and loss control programs between RIS and insurers.
- **Customer Service & Vendor Management.** Claims assistance as needed along with a review of workers compensation experience modifications as needed.

CLAIMS CONSULTING.

The world of insurance claims is often unfamiliar, confusing, and complicated. That's why we invest in claims advocates who have the expertise to guide you through the claims process, providing support that can include:

- Reviewing existing claims reporting and claims handling procedures and/or developing new claims-handling agreements
- Performing loss and reserve analyses
- Auditing selected claim files
- Working with brokerage-placement teams to prepare statistical analyses on claims data and trends for renewal submissions and underwriting negotiations
- Monitoring carrier or third-party-administrator claims-handling performance
- Keeping you informed of relevant insurance marketplace, legal, or legislative issues or developments

LOSS CONTROL.

We invest in post-loss claim advocacy resources to help you manage claims that have already occurred. We also have loss-control consulting staff who are skilled at helping you design and implement pre-loss programs to limit or avoid claims before they happen. We work with you to integrate risk-management, risk-control, and loss-prevention activities into your operations.

We have an extensive suite of loss-control and safety services tailored to meet the needs of both general and specialized industries, including:

- Evaluation of current programs, policies, and procedures
- Safety inspections
- Loss-history trend analysis and operational risk identification
- Loss-control and safety-program design and implementation
- Onsite or online safety training for employees and supervisory staff
- Regulatory compliance (e.g., OSHA and DOT)
- Employee and fleet safety manuals
- Ergonomics evaluations and training
- Accident-investigation and loss-recovery protocols/procedures
- Return-to-work programs

Relation possesses the financial stability and operational capacity to successfully fulfill all services outlined in the scope of services detailed in the RFP. With a robust financial standing, Relation is well-positioned to meet the requirements and expectations specified in the RFP. Importantly, over the past five years, Relation has maintained a track record free from any contract terminations due to default or other incidents, underscoring the reliability and commitment that the company brings to its contractual obligations.

ACTIVITY	START DATE	TEAM MEMBER
<ul style="list-style-type: none"> • Complete renewal specifications based on updated information. • Submit complete submission to agreed upon markets. • Coordinate travel and schedule carrier meetings with Relation staff to discuss market strategy and program goals for the program year. (We encourage face-to-face meetings between our clients and the underwriters). 	90-120 days prior to renewal	Kim Plescia
<ul style="list-style-type: none"> • Receive quotes. • Begin analysis of quotes and coverage/ pricing terms. (Subject to timely market response). • Continuous communication with insured advising of progress and indications. 	60-100 days prior to renewal (if market allows)	Kim Plescia
<ul style="list-style-type: none"> • Presentation of final proposal and recommendations we feel are in your best interest. Fully disclose names of carriers approached and optional quotes received. • Final binding plans to insured's request. 	30-45 days prior to renewal	Rick Grubb and Kim Plescia

ACCOUNT EXECUTIVES

The Account Executive works closely with risk management staff and coordinates the efforts of all elements of the Relation Client Service Team. Account Executives are leaders in the insurance industry. They are versed in a variety of disciplines which allows them to respond to a wide range of client needs.

- **BRODERICK C. “RICK” GRUBB**, Vice President, has more than 50 years of experience in underwriting, marketing, sales, and risk management. Rick specializes in public entity placements, healthcare, and other large casualty risks. He has served as a corporate officer with many of the largest insurance brokerage firms in the country including Johnson and Higgins, Marsh USA and HUB International.

As the first Director of Underwriting/Marketing for Louisiana Medical Mutual Insurance Company (LAMMICO), he was instrumental in establishing and developing the company’s underwriting and pricing policies and procedures. Additionally, he was part of the executive team that helped LAMMICO achieve its first A- (Excellent) rating from A.M. Best.

Rick has been the producer-of-record for the Louisiana Hospital Association Trust Fund. In this capacity, he has negotiated reinsurance and excess casualty placements to provide coverage to over 70 private and public institutions insured in the Fund. Rick also assisted the administrators of the Fund in procuring a state-of-the-art Risk Management Information System.

He has a Bachelor of Arts from Macalester College in St. Paul, MN and a Master of Business Administration from Loyola University New Orleans.

- **KIM M. PLESCIA**, CIC, Assistant Vice President, has over 25 years of property, casualty, and surety experience in all aspects of the technical service area to include submissions, marketing, risk management, policy review and customer service.

Kim is responsible for the workflow management, carrier relations and marketing. Ms. Plescia is a Professional Member of The National Society of Certified Insurance Counselors and holds a Certified Insurance Counselor (CIC) designation. Kim has a Bachelor of Arts degree from Louisiana State University in Baton Rouge, Louisiana.

ACCOUNT ADVISORS

Serving as the team’s Industry Resource, Account Advisors share their broad understanding of a client’s needs and objectives with Relation’s account specialists who are responsible for producing the desired results. Due to their strong knowledge of the industry specific insurance marketplace, they play a large role in program design and marketing. Account Advisors coordinate with the Account Executive to implement each client’s insurance program and serve client needs on a day-to-day basis.

- **JASON W. WILLIAMS**, ARM, Vice President, Property Broker, has over 20 years of experience in procuring, designing, marketing, and implementing risk-transfer programs for complex commercial and public entity property accounts. Jason graduated with a BBA in both Risk Management & Insurance and Real Estate from the University of Georgia. He earned the accreditation of Associate in Risk Management and is a member of NAPSLO (National Association of Professional Surplus Lines Offices, Ltd) where he serves on several advisory committees.

- **BROOKS COCHRAN**, Assistant Vice President, is an experienced Casualty and Excess Liability Broker. Brooks enjoys developing new and creative insurance products. He has superior knowledge of industry trends, losses, coverages and the pricing of public entity, construction, and manufacturing risks. His responsibilities include designing, servicing, and consulting on casualty placements. Prior to his current employment, Brooks worked six years for a leading specialty lines underwriting team at Philadelphia Insurance Companies.

Brooks graduated with a Bachelor of Arts degree in Government from St. Lawrence University in Canton, New York, and a Master of Business Administration from the University of Denver.

- **JEFFREY R. TROYER**, SCLA, Claims Specialist, Jeffrey has over 35 years of experience in the insurance industry. He has managed claims for many commercial insurers, identified claim related risk exposures, and worked as a third-party claim administrator within the public and private sectors. His areas of expertise include claim and risk management issues arising out of all lines of insurance including general liability, automobile liability, excess insurance, property, and workers compensation.

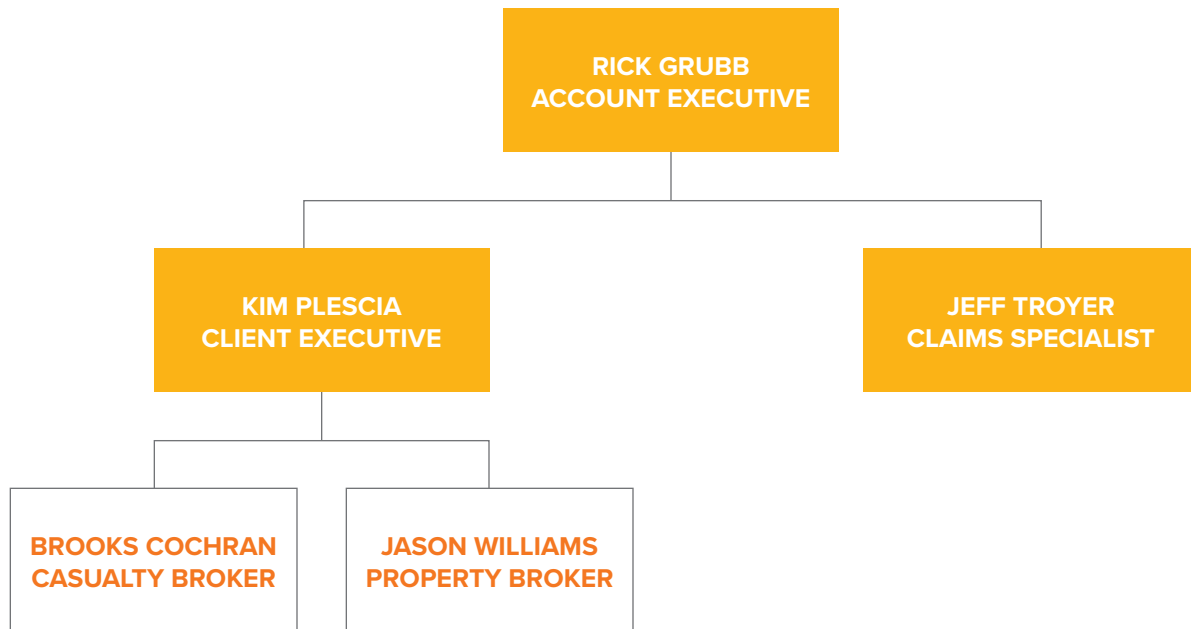

FORM CQ - 2012

Instructions: The prime, each subcontractor, and any other tier subcontractor must submit a fully completed CQ-2012 form. All items requested on the form are required, if an item is not applicable, respondents are instructed to enter N/A. Each prime firm participating as a joint venture should complete a separate CQ-2012 form and indicate on the form in item 10 that the response is a joint venture.

<p>Regional Transit Authority Contractor/Consultant Questionnaire CQ-2012</p>	<p>1. Project name, project number and date of submittal: Insurance Brokerage Services RFP #2025-007 February 19, 2025</p>	<p>2. Official name of firm, indicate if prime or subcontractor: BRK Insurance Group-A Relation Company</p>	<p>3. Address of office to perform work: 935 Gravier Street, Suite 1350 New Orleans, LA 70112</p>																				
<p>4. Name of parent company, if any: Relation Insurance Services, Inc.</p>	<p>5. Location of headquarters (city): 1277 Treat Blvd., Suite 400 Walnut Creek, CA 94597</p>	<p>6. Name, title, and telephone number of principal contact: Broderick "Rick" Grubb Vice-President 504.558.9391 (o) 504.481.8962 (m)</p>	<p>7. Name, title, and telephone number of project manager: Broderick "Rick" Grubb Vice-President 504.558.9391 (o) 504.481.8962 (m)</p>																				
<p>8. Specify Type of Business Entity:</p> <p><input checked="" type="radio"/> Corporation</p> <p><input type="radio"/> Proprietorship</p> <p><input type="radio"/> Partnership</p> <p><input type="radio"/> Limited Liability Corporation (LLC)</p> <p><input type="radio"/> Other</p>	<p>9. Indicate Special Status:</p> <p><input type="checkbox"/> Small business</p> <p><input type="checkbox"/> Minority-owned business</p> <p><input type="checkbox"/> Woman-owned business</p>	<p>10. Indicate certifications held regarding special status:</p> <p><input type="checkbox"/> SBE certified</p> <p><input type="checkbox"/> SLDBE certified</p> <p><input type="checkbox"/> LAUCP certified</p>	<p>11. Is this submittal a joint venture (JV)?</p> <p>Yes <input type="radio"/> No <input type="radio"/></p> <p>If so, has the JV worked together before?</p> <p>Yes <input type="radio"/> No <input type="radio"/></p> <p>Indicate the legal name of the JV:</p>																				
<p>12. List full-time personnel by primary function. Count each only once.</p> <table border="1"> <thead> <tr> <th>#</th> <th>Function (e.g. civil engineer)</th> </tr> </thead> <tbody> <tr><td>1</td><td>Account Manager</td></tr> <tr><td>1</td><td>Client Manager</td></tr> <tr><td>1</td><td>Claims Executive</td></tr> <tr><td>1</td><td>Risk Manager Consultant</td></tr> <tr><td>1</td><td>Property Placement Executive</td></tr> <tr><td>1</td><td>Casualty Placement Executive</td></tr> <tr><td>1</td><td>Retiree Employee Benefits Consultant</td></tr> <tr><td></td><td>Total Personnel Domiciled in LA</td></tr> <tr><td></td><td>Total Personnel</td></tr> </tbody> </table>				#	Function (e.g. civil engineer)	1	Account Manager	1	Client Manager	1	Claims Executive	1	Risk Manager Consultant	1	Property Placement Executive	1	Casualty Placement Executive	1	Retiree Employee Benefits Consultant		Total Personnel Domiciled in LA		Total Personnel
#	Function (e.g. civil engineer)																						
1	Account Manager																						
1	Client Manager																						
1	Claims Executive																						
1	Risk Manager Consultant																						
1	Property Placement Executive																						
1	Casualty Placement Executive																						
1	Retiree Employee Benefits Consultant																						
	Total Personnel Domiciled in LA																						
	Total Personnel																						

14. Brief resumes of key persons anticipated for this project (clearly identify if alternate office location if different than listed in item 5).

<p>a. Name and title: Broderick "Rick" Grubb, Vice President Account Manager</p>	<p>b. Position or assignment for this project: Account Manager</p>
<p>c. Years of professional experience with this firm: 3 With other firms: 49</p>	<p>d. Education: College or University/ Degree / Year / Specialization Macalester College/ BA/ 1973/Economics Loyola University New Orleans/MBA/1987/Administration and Marketing</p>
<p>e. Active registration or applicable certifications: State / Discipline/ License number / First year registered Licensed in all lines of insurance in Louisiana including property, casualty, employee benefits and surplus lines Louisiana License #124090 First licensed: 5/16/1980</p>	<p>f. Experience and qualifications relevant to this project: Over 50 years of commercial liability insurance and employee benefits experience in the areas of management, underwriting, sales, marketing, risk management, and communications. Diversified background working with a wide range of clients specializing in property, casualty, reinsurance and difficult placements (including the RTA and the Louisiana Superdome. Special knowledge of placing insurance and servicing public entities. I have serviced the RTA since 2007.</p>
<p>a. Name and title: Kim Plescia, Assistant Vice President Client Executive</p>	<p>b. Position or assignment for this project: Client Executive</p>
<p>c. Years of professional experience with this firm: 3 With other firms: 29</p>	<p>d. Education: College or University/ Degree / Year / Specialization Louisiana State University/BA/Journalism/1986</p>
<p>e. Active registration or applicable certifications: State / Discipline/ License number / First year registered Certified Insurance Counselor Designation Licensed in all lines of insurance in Louisiana including property, casualty, employee benefits and surplus lines Louisiana License #246806 First licensed: 5/26/1999</p>	<p>f. Experience and qualifications relevant to this project: Significant experience in underwriting, marketing, placing and servicing the insurance and risk management needs for large and complicated risks. Always available to provide the best and most comprehensive service available. Kim has worked on the RTA account since 2007.</p>

14. Brief resumes of key persons anticipated for this project (clearly identify, if alternate office location is different than listed in item 5).

<p>a. Name and title: Jeffrey R. Troyer, SCLA</p> <p>b. Position or assignment for this project: Claims Specialist</p> <p>c. Years of professional experience with this firm: 2 With other firms: 35</p> <p>d. Education: College or University/ Degree / Year / Specialization Taylor University, Greenville SC/BA/1985/Sociology and Pre-Law</p>	<p>a. Name and title:</p> <p>b. Position or assignment for this project:</p> <p>c. Years of professional experience with this firm: With other firms:</p> <p>d. Education: College or University/ Degree / Year / Specialization</p>
<p>e. Active registration or applicable certifications: State / Discipline/ License number / First year registered Senior Claim Law Associate, Insurance Claims Law/Management 1991</p>	<p>e. Active registration or applicable certifications: State / Discipline/ License number / First year registered</p>
<p>f. Experience and qualifications relevant to this project: Jeffrey has over 35 years of experience in the insurance industry. He has managed claims for many commercial insurers, identified claim related risk exposures, worked as a third-party claim administrator within the public and private sectors and managed all aspects of an insurance program for a large healthcare system. His areas of expertise include claim and risk management issues that arise from all lines of commercial, professional, general, auto, property and worker's compensation liability exposures with an emphasis on complex liability claim management. He has strong inter-personal communication skills emphasizing team building and cooperation among members, clients, and market relationships. Jeffrey has been highly successful as a Property & Casualty claims and insurance products manager combining formal education with post-graduate legal, medical, insurance and risk management education and certifications.</p>	<p>f. Experience and qualifications relevant to this project:</p>

15. List work by firm and the firm's personnel to be assigned to this project which best illustrates current qualifications relevant to this project (limit 15 projects).

a. Project name, location, and owner's name	b. Reference contact name, telephone number, and e-mail	c. Project description	d. Nature of firm's responsibilities	e. Completion date (actual or estimate)	f. Estimated fees (000's)	
					Entire project	Firm's work
New Orleans RTA New Orleans, LA	Marc Popkin Lona Hankins mpopkin@rtforward.org lhankins@rtforward.org 504.248.3900	Insurance Brokerage Services	Handle all property and casualty insurance requirements for the RTA as well as servicing the employee benefits for RTA and TMSEL Retirees	Currently handling	\$432,500 per year	\$358,500 per year
St. Charles Parish Public Schools	Darrinsha Gales dgalles@wearescpss.org 985.785.7295	Insurance Brokerage Services	Handle all property insurance requirements for SCPPS	Currently handling	\$462,000 per year	\$462,000 per year
Orleans Parish Sheriff's Office	Sheriff Susan Hutson 512.461.0884 hutsons@opso.us	Insurance Brokerage Services	Handle all property insurance requirements for OPPO	Currently handling	\$60,000 per year	\$60,000 per year
CLECO	Scott Fazio 504.952.4541 Fazio.risk@gmail.com	Insurance Consulting Services	Property and Casualty Consulting Services	Currently handling	\$40,000 per year	\$40,000 per year
St. John The Baptist Sheriff's Office	Sheriff Mike Tregre 985.652.9513 m.tregre@stjohnsheriff.org	Insurance Brokerage Services	Property and Casualty Insurance Services	Currently handling	\$60,000 per year	\$60,000 per year
City of Opelousas	Mayor Don Cravins 337.789.5387 dcravins@gmail.com	Insurance Brokerage Services	Handle all property and casualty insurance requirements for the RTA as well as servicing the employee benefits for the City of Opelousas	2012	\$100,000 per year	\$100,000 per year

CQ – 2012 Page 4

16. List all projects currently under contract or under contract negotiations that are being (or will be) performed by the firm's office as listed in item 3.

a. Project name, location, and owner's name	b. Nature of firm's responsibility	c. Indicate whether work completed as prime, subconsultant or joint venture	d. Percent complete	e. Estimated fees (000's)	
				Total fee	Fee remaining
See answers to question #15. All clients are handled by personnel located at 935 Gravier Street, Suite 1350, New Orleans, LA 70112					

CQ – 2012 Page 5

17. Use this space to provide any additional information or description of resources supporting your firm's qualifications for the proposed project.

See attached.

18. Ethics Questionnaire: If any owner, officer, or employee of respondent or any of the respondent's subcontractors (whether identified in the submittal or not) is currently an officer, employee, or board member of the City of New Orleans or of any of its departments, boards, or commissions, committees, authorities, agencies, public trusts, or public benefit corporations, please state the name or names of said owner, officer or employee, the relationship to respondent and/or respondent's subcontractor(s), the relationship with City board, agency, department, commission, authority, public trust, or public benefit corporation; if respondent or person(s) identified believe that the relationship is not or would not be a violation of applicable ethics laws, fully explain why not. If applicable, please complete ethics questionnaire on company letterhead attached to the back of this form. By signing below, you have completed the ethics questionnaire or you have not identified any ethical conflict at this time.

19. Pursuant to Louisiana Revised Statute 42:6.1, I hereby authorize the Regional Transit Authority to discuss the character and professional competence of this firm in Executive Session.

20. The forgoing is a statement of facts.

Signature: Broderick C. Grubb
Typed Name: Broderick Grubb

Date: February 19, 2025
Title: Vice President

Question #17 CQ-2012

Separately, I have provided information about Relation Insurance Services, Inc. (RISI) We have the assets, the markets, the people, and the expertise to respond to this RFP and provide the RTA with the products and services required.

However, we are not a new commodity. RISI, formerly BRK Insurance Group (BRK), has been a part of the RTA family for some time. Let us review our history together to gain perspective on where we have been and what we need to do together to improve the risk profile of the RTA.

BRK, in a joint venture with The Kennedy Financial Group, has marketed and placed the property and casualty insurance and supported RTA retirees since 2007. The previous broker for the RTA was a Top 5 insurance brokerage firm. We faced stiff competition competing against larger firms. However, we were able to convince the RTA evaluation team that our two local firms, with our extensive education and experience, could produce better results than the internationally known and much larger incumbent firm. We were able to convince the RTA that we would outwork anyone, be available as needed, listen to better understand RTA needs, educate RTA executives and staff to enable them to make more informed business decisions while treating RTA leadership with the respect they deserved.

We became your Broker of Record and immediately learned that the automobile liability and general liability insurance for the RTA would not be renewed by the carrier at that time with no acceptable alternative. We had ninety (90) days to find a solution so that busses and streetcars could continue to operate with insurance. This was important because the RTA was in no position to self-insure this exposure. I immediately got on the phone to find an answer. Fortunately, I was able to use my personal contacts to find a business partner that would agree to insure the RTA. That was not an easy task because the RTA claims history was not particularly good and there was no risk management structure in place to improve the situation. We had to change how things were done and how the RTA was perceived to create a better future for the RTA.

We immediately instituted the following actions to improve the casualty risk profile of the RTA:

1. Quarterly meetings with RTA staff, the TPA, and RTA legal counsel to discuss large claims made against the RTA to learn about the causes and to minimize or eliminate similar claims in the future.
2. Annual meetings between the underwriter and RTA staff to enhance and improve our partnership.
3. Work with RTA leadership and legal counsel to speed up the time to resolve and settle claims.
4. Improve the reliability of the information provided by the TPA by encouraging timely reporting by legal counsel to the TPA.
5. Educating RTA staff on market conditions, market availability, safety/risk management, risk retentions, new product availability.

The RTA is a difficult automobile liability placement because of the streetcar exposure. There are few markets available that are willing to consider the RTA as a client because of the that unique exposure. This is not going to change in the immediate future as more markets are exiting. I do have an excellent personal relationship with the President of our current insurer. That helps us maintain our partnership and continuity of coverage. However, every year is a challenge as market appetites are becoming increasingly conservative. I am looking forward to working with RTA leadership in the next year to discuss how we might create more security and less premium volatility.

Property insurance is a difficult placement for us because RTA property assets are in a catastrophic zone. This is not going to change anytime soon. However, we have been able to produce stable pricing with reasonable terms over the years. In fact, our results are better than what the general property market bears. We work the entire domestic and international marketplace to produce the best results. We will continue to do so.

We are the face of the RTA when it comes to providing services to retired employees of the RTA. Retirees were quite dissatisfied before we entered the picture. Now, complaints are almost non-existent. We continue to provide retirees with the kind of responsive and attentive services that they require. That reduces headaches for RTA leadership.

It has been our honor and privilege to serve the RTA. We strive to be the kind of partner that shines a positive light on RTA leadership and the Board. We hope that you will continue to allow us to be your trusted insurance broker and advisor for the next three (3) years. Relationships Matter!

Sincerely,



Broderick Grubb

NON-COLLUSION AFFIDAVIT

STATE OF Louisiana
PARISH OF Orleans

BRODERICK GRUBB, being first duly sworn, deposes and says that:

- (1) He is (Owner) (Partner) (Officer) (Representative) or (Agent), of RELATION INSURANCE SERVICES, INC., the Contractor that has submitted the attached bid;
- (2) Such Bid is genuine and is not a collusive or sham Bid.
- (3) The attached bid is not made in the interest of or on behalf of any undisclosed person, partnership, company association, organization or corporation; that such bid is genuine and not collusive or sham; that said bidder has not, directly or indirectly, induced or solicited any other bidder to put in a false or sham bid, and has not, directly or indirectly colluded, conspired connived or agreed with any bidder or anyone else to put on a sham bid, or refrain from bidding; that said bidder has not in any manner, directly or indirectly, sought by agreement, communication or conference with anyone to fix the bid price of said bidder or any other bidder, or to fix any overhead, profit, or cost element of such bid price or that of any other bidder, or to secure any advantage against RTA or anyone interested in the proposed contract; that all statements contained in such bid are true; that said bidder has not, directly or indirectly, submitted his bid price or any breakdown thereof or the contents thereof, or divulged information or data relative thereto, or paid or agreed to pay, directly or indirectly, any money or other valuable consideration for assistance or aid rendered or to be rendered in procuring or attempting to procure the contract above referred to, to any corporation, partnership, company, association, organization or to any member or agent thereof, or to any other individual; and further that said bidder will not pay or agree to pay directly or indirectly, any money or other valuable consideration to any corporation, partnership, company, association, organization or to any member or agent thereof, or to any individual, for aid or assistance in securing contract above referred to in the event the same is awarded to said bidder.

Signed: [Signature]
Title: Vice-President

Sworn to me and subscribed in my presence this 28th day of January, A.D. 2025

[Signature] Eric M. Ferrocillet
NOTARY PUBLIC
LA. BAR #05544
Lifetime Commission

**CERTIFICATION ON PRIMARY PARTICIPANT
REGARDING DEBARMENT, SUSPENSION, AND
OTHER RESPONSIBILITY MATTERS**

The Primary Participant (Potential Contractor for a major third party contract), certifies to the best of its knowledge and belief, that it and its principles:

1. Are not presently debarred, suspended, proposed for debarment, declared ineligible, or voluntarily excluded from covered transactions by any Federal Department or agency;
2. Have not within a three-year period preceding this proposal been convicted of or had a civil judgment rendered against them for commission of fraud or a criminal offense in connection with obtaining, attempting to obtain, or performing a public (federal, State, or local) transaction; violation of Federal or State antitrust statutes or commission of embezzlement, theft, forgery, bribery, falsification or destruction of records, making false statements, or receiving stolen property;
3. Are not presently indicted for or otherwise criminally or civilly charged by a government entity (Federal, State, or local) with commission of any of the offenses enumerated in paragraph (2) of this certification; and
4. Have not within a three-year period preceding this application/proposal had one or more public transactions (Federal, State or local) terminated for cause or default.

(If the primary participant is unable to certify to any of the statements in this certification, the participants shall attach an explanation to this certification.)

THE PRIMARY PARTICIPANT, (POTENTIAL CONTRACTOR FOR A MAJOR THIRD PARTY CONTRACT, CERTIFIES OR AFFIRMS THAT TRUTHFULNESS AND ACCURACY OF THE CONTENTS OF THE STATEMENTS SUBMITTED ON OR WITH THIS CERTIFICATION AND UNDERSTANDS THAT THE PROVISIONS OF 31 U.S.C. SECTION 3801 ET SEQ ARE APPLICABLE HERETO.

COMPANY Relation Insurance Services, Inc.
ADDRESS 935 Gravier St., Ste. 1350, New Orleans, LA 70112

DATE 2/14/2025

TR
Signature of Offeror's Authorized Representative

**CERTIFICATION REGARDING DEBARMENT
SUSPENSION, INELIGIBILITY AND VOLUNTARY
EXCLUSION - LOWER TIER COVERED TRANSACTION**

- 1. The prospective lower tier participant certifies, by submission of this offer, that neither it nor its principals is presently debarred, suspended, proposed for debarment, declared ineligible, or voluntarily excluded from participation in this transaction by any Federal department or agency.**
- 2. Where the prospective lower tier participant is unable to certify to any of the statements in this certification, such prospective participants shall attach an explanation to this offer.**
- 3. The Lower-Tier participant (Potential Contractor under a major Third Party Contract), certifies or affirms the truthfulness and accuracy of the contents of the statements submitted on or with this certification and understands that the provisions of 31 U.S.C., 3801 ET SEQ are applicable thereto.**

COMPANY Relation Insurance Services, Inc.
ADDRESS 935 Graiver St., Ste. 1350, New Orleans, LA. 70112
DATE 2/14/25
RS

Signature of Offeror's Authorized Representative

CERTIFICATION OF RESTRICTIONS ON LOBBYING

I, Broderick Crabb, Vice-President hereby certify on
(Name and Title of Offeror Official)

behalf of Relation Insurance Services, Inc. that:
(Name of Offeror)

- (1) No Federal appropriated funds have been paid or will be paid, by or on behalf of the undersigned, to any person for influencing or attempting to influence an officer or employee of any agency, a Member of Congress, an officer or employee of Congress, or an employee of a Member of Congress in connection with the awarding of any Federal contract, the making of any Federal grant, the making of any Federal loan, the entering into of any cooperative agreement, and the extension, continuation renewal, amendment, or modification of any Federal contract, grant, loan or cooperative agreement.
- (2) If any funds other than Federal appropriated funds have been paid or will be paid to any person for influencing or attempting to influenced an officer or employee of any agency, a Member of Congress, an officer or employee of Congress, or an employee of a Member of Congress in connection with this Federal contract, grant, loan, or cooperative agreement, the undersigned shall complete and submit standard Form-LLL, "Disclosure Form to Report Lobbying," in accordance with its instructions.
- (3) The undersigned shall require that the language of this certification be included in the award documents for all sub-awards at all tiers (including subcontracts, sub-grants, and contracts under grants, loans, and cooperative agreements) and that all sub-recipients shall certify and disclose accordingly.

This certification is a material representation of fact upon which reliance is placed when this transaction was made or entered into. Submission of this certification is a prerequisite for making or entering into this transaction imposed by section 1352, title 31, U.S. Code. Any person who fails to file the required certification shall be subject to a civil penalty of not less than \$10,000 and not more than \$100,000 for each such failure.

Executed this 28th day of January, 2025

WITNESS: Jim Garcia

BY: [Signature]
Witnesses: _____
(Signature of Authorized Official)

Vice-President

(Title of Authorized Official)

Sworn to and subscribed before me on this 28th day of January 2025

Notary Public In and For Orleans Parish County

State of Louisiana

Eric M. Ferreollet
LA BAR # 05544
Lifetime Commission

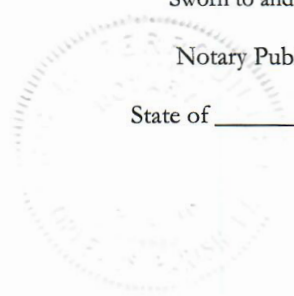

PARTICIPANT INFORMATION FORM

All offerors are required to submit the information contained on this form. This information is a condition of submitting an offer to the RTA. Offerors must insure that **ALL** sub-contractors, sub-contractors or others at all tiers, which are proposed to be used or used under any agreement issued by RTA have submitted an executed copy of this form. RTA is required to maintain this information by the Federal Transit Administration and it is not subject to waiver.

Firm Name Relation Insurance Services, Inc.
 Firm Address 935 Gravier St., Ste. 1350, New Orleans, LA 70112
 Telephone Number 504.558.9391
 Fax Number 504.558.9392
 E-Mail Address rick.grubb@relationinsurance.com
 Firm's status as Disadvantaged Business Enterprise (DBE) or Non- DBE N/A
 Age of the firm 17+ years
 Annual gross receipts of the firm \$ 213,000,000
 Prime or Sub-Contractor Prime
 NAICS code (s) 524210
 I certify to the best of my knowledge that the above information is true and correct:
 Signature [Signature]
 Title Vice - President
 Date 2/14/2025
 RTA Project No. RFP# 2025-007

FAILURE TO PROVIDE AN EXECUTED COPY OF THIS FORM AS STIPULATED HEREIN MAY PRECLUDE YOUR OFFER FROM CONSIDERATION FOR AWARD.

RTA Regional Transit Authority
DBE FORM 4 --DBE PARTICIPATION PLAN (For RFPs and RFQs)

RESPONDENTS TO RFPs AND RFQs: This completed form must be furnished with your proposal. You must complete every section of the form or your proposal will be deemed non-responsive. If a section is not applicable to your proposal, you must explain why it is not applicable or your proposal will be deemed non-responsive. You must submit your response on the DBE Responsiveness Form 4 or your proposal will be deemed non-responsive. You may use additional pages as warranted.

RF/RFQ/Solicitation #: 2025-007 Date: 02/14/2025
 Description: F.S. Brokerage Services + Employee Benefits
 Name of Respondent: Broderick D. "Pick" Gault for Reliance Insurance Services, Inc.

- Please check the appropriate space:
- The proposer is committed to the contract goal of 0 % DBE utilization on this contract. (If selected, you must complete and submit DBE Compliance Form 1 and 2 in order to be awarded a contract.)
 - The proposer is unable to meet the DBE contract goal, however is committed to a minimum of _____ % DBE utilization on this contract and will submit documentation demonstrating good faith efforts. (If selected, you must complete and submit DBE Compliance Forms 1 and 3 and DBE Compliance Form-2 if applicable along with all required supporting documentation in order to be awarded a contract.)

SECTION I - DBE COMMITMENT TO CONTRACT GOAL: You must list all DBE firms that you have identified to participate on the contract. **PLEASE NOTE: Every DBE firm listed MUST be utilized on the project. To remove and/or replace a DBE firm you must submit a request for removal and substitution and you must receive approval from the DBELO to remove and/or replace the firm.**

DBE FIRM & NAME of DBE	PHONE	SOURCE OF CERTIFICATION (SLDBE or LAUCP)	SCOPE OF WORK TO BE PERFORMED BY THE DBE	VALUE of PROPOSED CONTRACT with DBE (If Known)	ESTIMATED % OF TOTAL CONTRACT
1.				\$	%
2.				\$	%
3.				\$	%
4.		N/A		\$	%
5.				\$	%
6.				\$	%
7.				\$	%
8.				\$	%
TOTALS				\$	%

RTA **Regional Transit Authority**
DBE FORM 4 --DBE PARTICIPATION PLAN (For RFPs and RFQs)

SECTION II - DBE AFFIRMATIONS: For the DBE firms listed above, please provide the name and signature of the firm's authorized representative.

NAME OF DBE FIRM	PRINT NAME OF DBE FIRM'S AUTHORIZED REPRESENTATIVE	SIGNATURE OF DBE FIRM'S AUTHORIZED REPRESENTATIVE	DATE
	N/A		

SECTION III - SPECIFIC PORTIONS OF WORK IDENTIFIED FOR DBE SUBCONTRACTOR: If you have not identified DBE firms for attainment of the DBE goal and have not listed a commitment to specific DBE firms for participation in Section I that equals the total contract goal for this project, you must list all selected scopes or portions of work that you identified to be performed by DBE(s) and the estimated percentage value of each scope of work identified in order to increase the likelihood of meeting the contract goal for this project.

SCOPE OR PORTIONS OF WORK IDENTIFIED FOR DBE PARTICIPATION		ESTIMATED % OF CONTRACT VALUE
1.		
2.		
3.		
4.		
5.		
6.		
7.		
8.		
TOTAL		

N/A

RTA  *Regional Transit Authority*
DBE FORM 4 --DBE PARTICIPATION PLAN (For RFPs and RFQs)

SECTION IV - PAST PERFORMANCE: You must provide details of your firm's past performance in compliance with DBE goals.

AGENCY NAME	PROJECT NAME	COMPLETION DATE	DBE PARTICIPATION ACHIEVED	DBE OFFICE VERIFICATION
NORA	Isiswara Broker	Current	35%	

SECTION V - OTHER: If you have not identified DBE firms for attainment of the DBE goals and have not listed commitments to specific DBE firms for participation in Section I that equals the total contract goal for this project, you must provide narrative details of any other efforts your firm will conduct to attain the DBE goal.

1.15 ADDENDA

Proposers shall acknowledge receipt of all addenda to this Request for Proposals. Acknowledged receipt of each addendum shall be clearly established and included with each proposal. The undersigned acknowledges receipt of the following addenda.

Addendum No. 1, dated 02/11/2025
Addendum No. 2, dated 02/13/2025
Addendum No. _____, dated _____

Relation Ins. Services, Inc.
Company Name
BL
Company Representative
Broderick Grubb

RFP 2025-007

YEAR	FEE FOR SERVICES
YEAR 1	\$25,000 per month, \$300,000 annually
YEAR 2	\$25,000 per month, \$300,000 annually
YEAR 3	\$25,000 per month, \$300,000 annually

The respondent, in the performance of any contract resulting from this solicitation, does not intend to use one or more plants or facilities located at a different address from the address of the respondent as indicated in this proposal or response to request for information.

By: Broderick C. Grubb
Broderick C. Grubb



Relation Insurance Services

935 Gravier St, Ste 1350

New Orleans, LA 70112

(504) 558-9390

LA License #526540

relationinsurance.com



Board Report and Staff Summary

File #: 25-023

Finance Committee

Change Order Request- Carr, Riggs, & Ingram Contract (RFQ2019-021)

DESCRIPTION: The purpose of this request is to increase the contract amount for Carr, Riggs & Ingram to cover remaining audit services for the year ending December 31, 2024.	AGENDA NO: Click or tap here to enter text.
ACTION REQUEST: <input checked="" type="checkbox"/> Approval <input type="checkbox"/> Review Comment <input type="checkbox"/> Information Only <input type="checkbox"/> Other	

RECOMMENDATION:

To authorize the Chief Executive Officer to increase the contract amount by \$157,534 for Carr, Riggs & Ingram to cover the audit services for the year ending December 31, 2024. (RFQ2019-021)

ISSUE/BACKGROUND:

In January 2020, Carr, Riggs & Ingram was awarded a \$710,000 contract for annual audit services over five years, including \$623,100 for financial audits and \$86,900 for agreed-upon procedures and National Transit Database (NTD) Statewide reporting.

In August 2024, a change order of \$75,000 was approved for 2023 audit services.

This request seeks approval for a change order of \$157,534 to cover the balance required for the 2024 audit services totaling \$175,450. The current purchase order has a remaining balance of \$17,926.35.

DISCUSSION:

This change order request is necessary to fund the completion of the 2024 audit services in the existing contract. The additional funding will ensure compliance with financial reporting requirements, including the Financial Statement Audit, Single Audit, Statewide Agreed-Upon Procedures, and National Transit Database (NTD) Agreed-Upon Procedures.

The total fee proposal of \$175,450 is allocated as follows:

- \$138,700 - External audit services in accordance with Generally Accepted Auditing Standards (GAAS), Government Auditing Standards, and the Uniform Guidance Single Audit.
- \$17,325 - Agreed-Upon procedures as required by the Louisiana Legislative Auditor.
- \$19,425 - Agreed-Upon procedures as required by the Federal Transit Administration for the National Transit Database.

FINANCIAL IMPACT:

The total additional cost required for this change order is \$157,534, which will be funded through

budget account 01-5100-02-7060-171-89-00-00000-00000.

NEXT STEPS:

Upon RTA Board approval, the change order will be processed, and the additional funds will be allocated accordingly.

ATTACHMENTS:

1. Resolution
2. Original Purchase Order (January 2020)
3. Change Order (August 2024)
4. Change Order Routing (February 2025)
5. Carr, Riggs & Ingram- Fee Proposal for year ended December 31, 2024
6. Carr, Riggs & Ingram- Original Executed Contract

Prepared By: Jessica M. Lang
Title: Business Analyst

Reviewed By: Gizelle Johnson-Banks
Title: Chief Financial Officer



Lona Edwards Hankins
Chief Executive Officer

3/11/2025

Date



RESOLUTION NO. _____

FILE ID NO. 25-023

STATE OF LOUISIANA
PARISH OF ORLEANS

**A RESOLUTION AUTHORIZING A CHANGE ORDER TO THE CONTRACT WITH CARR,
RIGGS & INGRAM TO INCREASE THE CONTRACT AMOUNT FOR THE AUDIT
SERVICES FOR THE YEAR ENDING DECEMBER 31, 2024**

Introduced by Commissioner _____, seconded by Commissioner
_____.

WHEREAS, the Regional Transit Authority (RTA) previously awarded a contract to Carr, Riggs & Ingram in January 2020, totaling \$710,000, for a five-year term to provide audit services, including Financial Audits, Single Audits, Statewide Agreed-Upon Procedures, and National Transit Database Agreed-Upon Procedures; and

WHEREAS, an approved change order in August 2024 increased the contract amount by \$75,000 for 2023 audit services; and

WHEREAS, the remaining funds on the current purchase order total \$17,926.35, which is insufficient to cover the full cost of the 2024 audit services; and

WHEREAS, the additional funding **SHALL NOT EXCEED ONE HUNDRED FIFTY SEVEN THOUSAND FIVE HUNDRED THIRTY-FOUR DOLLARS (\$157,534)** is required to cover the total \$175,450 necessary for the 2024 Financial Statement Audit, Single Audit, Statewide Agreed-Upon Procedures, and National Transit Database Agreed-Upon Procedures; and

WHEREAS, the funding for this change order will be allocated from budget account 01-5100-02-7060-171-89-00-00000-00000;

Resolution No. _____

Page 2

NOW, THEREFORE, BE IT RESOLVED by the Board of Commissioners of the Regional Transit Authority (RTA) that the Chairman of the Board, or his designee, authorizes a change order for \$157,534 to increase the contract amount with Carr, Riggs & Ingram to fully fund the 2024 audit services and to execute all necessary documents to process the change order and allocate the additional funds.

THE FOREGOING WAS READ IN FULL, THE ROLL WAS CALLED ON THE ADOPTION THEREOF AND RESULTED AS FOLLOWS:

YEAS: _____

NAYS: _____

ABSTAIN: _____

ABSENT: _____

**AND THE RESOLUTION WAS ADOPTED ON THE 25th
OF March 2025.**

**FRED A. NEAL, JR.
CHAIRMAN
BOARD OF COMMISSIONERS**

Regional Transit Authority
 INV.: Accounting Dept (504) 827-8407
 TO: 2817 Canal Street
 New Orleans, Louisiana 70119

Page - 1
 Date - 9/23/20
 Order No. - 912678-001
 Brn/Plt - 1110002

CARR, RIGGS & INGRAM (CRI)
 HERITAGE PLAZA
 111 VETERANS BOULEVARD
 SUITE 350
 METAIRIE LA 70005

SHIP REGIONAL TRANSIT AUTHORITY
 TO
 M. Major
 2817 CANAL STREET
 NEW ORLEANS, LA 70119

Ordered - 01/16/20 Vendor No. 6676187 Annual Audit 5 years
 Delivery - 01/16/20 Taken By - REQ #103901
 Freight - Default - Handling Code PROMISED DELIVERY DATE - 01/30/20

Description / Supplier Item	UM	Unit Cost	Extension
ANNUAL AUDIT FOR 5 YEARS	LS		623,100.00
Non Stock Inventory Purchas	EA		86,900.00
1110002.7060.171			
Agreed upon & NRD Statewide			
Non Stock Inventory Purchas			
1110002.7060.176			



Fiozell Daniels
 Chairman
 RTA Board of Commissioners

Terms Net 30 Tax Rt Sales Tax Total Order
 710,000.00

DATE RECEIVED _____
 RECEIVED _____
 BY _____
 CHECKED _____
 BY _____
 APPROVED _____
 BY _____

ORDER NUMBER AND PERSON TO WHOM ADDRESSED MUST APPEAR ON ALL PACKAGES AND INVOICES

REGIONAL TRANSIT AUTHORITY
 TAX EXEMPT
 BY *Maria Major*
 MANAGER, PURCHASING DEPT

ANY CONFLICT, DISPUTE, LEGAL PROCEEDING, SETTLEMENT OR OTHER MATTER HAVING A LEGALLY BINDING IMPACT ON THE PARTIES HERETO SHALL BE RESOLVED PURSUANT TO THE LAWS AND JURISPRUDENCE OF THE STATE OF LOUISIANA.

INV. DATE INV. NUMBER INV. AMOUNT TAX FREIGHT INV. TOTAL

Purchase Order 912678 Change Order 3

Order	912678
Order Date	01-OCT-2023
Change Order	3
Change Order Date	26-AUG-2024
Revision	2
Ordered	173,026.35 USD

Sold To Regional Transit Authority
 2817 Canal Street
 NEW ORLEANS, LA 70119

Supplier CARR, RIGGS, & INGRAM (CRI)
 200-B GREENLEAVES BLVD
 MANDEVILLE, LA 70448

Bill To RTABU
 Attn: Accounts Payable
 2817 CANAL STREET
 NEW ORLEANS, LA 70119
 UNITED STATES

Ship To 2817 CANAL STREET
 NEW ORLEANS, LA 70119
 UNITED STATES

Notes USD = US Dollar

Customer Account Number	Supplier Number	Payment Terms	Freight Terms	FOB	Shipping Method
	8676187	Net 30			
Confirm To	Deliver To Contact				
Briana Howze	Tiffany Robbins E-mail: tbrobbins@rtaforward.org				

Line	Item	Price	Quantity	UOM	Ordered	Taxable
1	Board of Comm.-Canal	1.00		EA		
		Promised	98,026.35	EA	98,026.35	
		Requested 9/30/23				
Requested and Promised Dates correspond to the date of arrival at the Ship-to Location.						
					Line Total	98,026.35
						(Balance carried over from the JD Edwards System)
2	2023 audit services	75,000.00				
		Promised			75,000.00	
		Requested				

Ship To
 Attn: Accounts Payable
 2817 CANAL STREET
 NEW ORLEANS, LA 70119

Proprietary and Confidential

Purchase Order 912678 Change Order 3

Line	Item	Price	Quantity	UOM	Ordered	Taxable
	UNITED STATES		B/25/24			

Requested and Promised Dates correspond to the date of arrival at the Ship-to Location.

Line Total 75,000.00

Total 173,026.35

Received
\$7,500 1/27/25



Regional Transit Authority Change Order Routing Sheet

INSTRUCTION: The user department is responsible for providing the information requested below (all parts), securing the requisite signatures, attaching a justification for the change order, and providing a responsibility determination, with pertinent contact information.

Date Created	March 5, 2025
Change Order ID	343

A. Department Representative to participate in procurement process.

Name: LANG, JESSICA
Title: ADMINISTRATIVE ANALYST FINANCE
Ext: 8436

B. Contract Information:

Contract Number	RFQ2019-021
PO Number	912678
Contract Title	New Orleans Regional Transit Authority Financial Statement Audit, Single Audit, Statewide Agreed-Upon Procedures, and National Transit Database Agreed-Upon Procedures for the year ended December 31, 2024. (RFQ2019-021)

Contract-History:

Original Award Value	710000
Previously Executed Change Order Value	75000
Adjusted Contract Value	785000
Current Change Order Value	157524
Revised Contract Value	942524

C. Justification of Change Order

Resubmission w/Corrected Previously Executed Change Order Value \$75K:

The change order request is for \$175,450.00 (per AP \$17,926.35 available on previous PO); \$157,524.00 is the newest changer order requested amount.

New Orleans Regional Transit Authority Financial Statement Audit, Single Audit, Statewide Agreed-Upon Procedures, and National Transit Database Agreed-Upon Procedures for the year ended December 31, 2024. (RFQ2019-021)

D. Type of Change Request: Administrative

E. Certification of Authorized Grant:

Is this item/specification consistent with the Authorized Grant?	
---	--



Are there any amendments pending?	
If yes see explanation (attachments are in the SharePoint folder for this request)	

Director of Grants/ Federal Compliance:
 Signature:
 Date:

F. Safety, Security, And Emergency Management: Include Standard Safety Provisions Only:

Additional Safety Requirements Attached: *false*

Chief: *Michael J Smith*
 Signature: *Michael J Smith*
 Date: *March 06 2025*

Risk Management:

Include Standard Insurance Provisions Only?	<i>No</i>
Include Additional Insurance Requirements Attached ?	<i>false</i>

Risk Management Analyst: *Marc L Popkin*
 Signature: *Marc L Popkin*
 Date: *March 06 2025*

G. Funding Source:

Independent Cost Estimate (ICE): *\$0.00*
 Projected Total Cost: *\$157,524.00*
 Funding Type: *Local*

Federal Funding	State	Local	Other
		<i>\$157,524.00</i>	
Projected Fed Cost	State	Local	Other
		<i>\$157,524.00</i>	

FTA Grant IDs	Budget Codes
	<i>01-5100-02-7060-171-89-00-00000-00000</i>

Capital Project Approval if required signature ID#:
 Dir Capital Projects:
 Signature:
 Date:



Budget Analyst: Divya Prem
Signature: *Divya Prem*
Date: March 05 2025

H. Prime firm’s DBE/SLDBE Commitment (NOTE: The Prime Firm must be notified by the Project Manager that the DBE Commitment percentage applies to the Total Contract Value after all amendments and change orders.):

DBE % Goal	0
SLDBE % Goal	0
SBE % Goal	0

Director of Small Business Development: Adonis Charles Expose'
Signature: *Adonis Charles Expose'*
Date: March 06 2025

DBE/EEO Compliance Manager: Adonis Charles Expose'
Signature: *Adonis Charles Expose'*
Date: March 06 2025

I. Authorizations: I have reviewed and approved the final solicitation document.

Department Head: Gizelle Johnson-Banks
Signature: *Gizelle Johnson-Banks*
Date: March 05 2025

Chief: Gizelle Johnson-Banks
Signature: *Gizelle Johnson-Banks*
Date: March 05 2025

Director of Procurement: Ronald Baptiste
Signature: *Ronald Baptiste*
Date: March 06 2025

Required if Total Cost above \$15K
Chief Financial Officer: Gizelle Johnson Banks
Signature: *Gizelle Johnson Banks*
Date: March 06 2025

Required if Total Cost above \$50K
Chief Executive Officer: Lona Edwards Hankins
Signature: *Lona Edwards Hankins*
Date: 3/6/2025 7:06 PM

FOR

New Orleans Regional Transit Authority

Financial Statement Audit, Single Audit,
Statewide Agreed-Upon Procedures, and
National Transit Database Agreed-Upon Procedures
for the year ended December 31, 2024

January 8, 2025

Proposer:

Carr, Riggs & Ingram, LLC
3850 N. Causeway Blvd., Suite 1400
Metairie, La 70002
(504) 833-2436
CRIadv.com

Submitted by:

Becky Hammond, CPA, CISA, CITP, CGAP
Partner

985.290.3684 • bhammond@cricpa.com

We value continuing mutually-rewarding, long-term relationships with our clients. Our goal is to provide high quality, responsive service that yields returns far greater than your investment in our professional fees.

Please find below our proposal of fees to provide the requested services for the upcoming year ended December 31, 2024.

SERVICES	CRI FEES
Perform external audit services in accordance with auditing standards generally accepted in the United States of America (GAAS) and <i>Government Auditing Standards</i> and perform the Single Audit in accordance with the Uniform Guidance.	\$138,700
Perform agreed-upon procedures as required by the Louisiana Legislative Auditor	\$17,325
Perform agreed-upon procedures as required by the Federal Transit Administration National Transit Database	\$19,425

The above fee estimate includes one major federal program for the Uniform Guidance Single Audit. Additional major federal programs will be \$10,000 - \$14,000 for each additional major program depending on the complexity of the program.

The above fee estimate does not include any additional services related to the implementation of new GASB standards or changes necessary to the financial statements as the result of such implementations. Estimates will be provided as it is determined these services are necessary and in consultation with management to determine the scope of services we are to provide.

If the RTA requests additional services outside of this proposal, professional fee hourly rates are as follows, but may be negotiated depending on the project request:

CLASSIFICATION	HOURLY RATE
Partner	\$340
Senior Manager	\$280
Manager	\$240
Supervising Senior	\$180
Senior	\$160
Staff	\$140
IT Specialist	\$340
Fraud Specialist	\$340



CONTRACT TO PROVIDE AUDIT & FINANCIAL OVERSIGHT

Regional
Transit
Authority

BY AND BETWEEN

REGIONAL TRANSIT AUTHORITY
A Political Subdivision of the
State of Louisiana
2817 Canal St.
New Orleans, Louisiana 70119

AND

CARR, RIGGS, & INGRAM, LLC
111 Veterans Blvd., Suite 350
Metairie LA, 70005

2817 Canal Street,
New Orleans,
Louisiana
70119-6301

A. SCOPE OF WORK

As specified herein.

B. CONTRACT PRICE:

As specified herein.

C. PERIOD OF PERFORMANCE:

As specified herein.

Administration

504.827.8300

TABLE OF CONTENTS

	PAGE
PARTIES TO CONTRACT	3
BASIC CONTRACT	3
ARTICLE I. SUPERSEDING EFFECT	4
ARTICLE II. SCOPE OF SERVICES	4
ARTICLE III. COMPENSATION	4
ARTICLE IV. TERMS OF AGREEMENT	5
ARTICLE V. TERMINATION	5
ARTICLE VI. INTEREST OF CONTRACTOR	5
ARTICLE VII. IDENTIFICATION OF DOCUMENTS	5
ARTICLE VIII. OWNERSHIP OF DOCUMENTS	6
ARTICLE IX. MEDIA COVERAGE	6
ARTICLE X. APPLICABLE LAW	6
ARTICLE XI. NOTICES	7
ARTICLE XII. DOCUMENTS INCORPORATED	
BY REFERENCE	7
ARTICLE XIII. ORDER OF PRECEDENCE	7
ARTICLE XIV. INSURANCE	8
ARTICLE XV. DBE COMPLIANCE	8
SIGNATURES	11
CERTIFICATION	12
ACKNOWLEDGEMENTS	13 & 14

EXHIBITS

EXHIBIT "A"	RTA Request for Quote (RFQ) #2019-021
EXHIBIT "B"	Bid Submittal by Contractor dated, August 21, 2019.
EXHIBIT "C"	FTA Clauses

AGREEMENT
BY AND BETWEEN
THE REGIONAL TRANSIT AUTHORITY
AND
CARR, RIGGS, & INGRAM, LLC

STATE OF LOUISIANA
PARISH OF ORLEANS

This AGREEMENT made and entered into this 27th day of January, 2020 by and between the REGIONAL TRANSIT AUTHORITY (hereinafter referred to as the "RTA"), a political subdivision of the State of Louisiana, herein represented by its Chairman of the Board of Commissioners, Flozell Daniels and Carr, Riggs, & Ingram, LLC (hereinafter also referred to as "Consultant" or "Contractor") a Corporation, herein represented by its CPA Partner Becky Hammond authorized to do and doing business in the State of Louisiana.

WITNESSETH

WHEREAS, the RTA is a political subdivision of the State of Louisiana, charged with the responsibility of providing, maintaining and administering a transit system in the areas within its jurisdiction; and

WHEREAS, in accordance with state and federal laws and regulations, RTA issued Request for Quote (RFQ) No. 2019-021, as amended, (attached hereto, made a part hereof and designated Exhibit "A", RTA RFQ No. 2019-021, as amended,) to solicit a contractor to provide Audit & Financial Oversight Services; and

WHEREAS, Carr, Riggs, & Ingram, LLC a Corporation, submitted a response to Exhibit "A" attached hereto, made a part hereof and designated as Exhibit "B",

Contractor's Bid Submittal dated, August 21, 2019, made a part hereof and attached hereto;
and

WHEREAS, after evaluation of Contractor's offer, RTA determined that Contractor was responsible and had submitted the responsive offer.

NOW, THEREFORE, IN CONSIDERATION of the promises and mutual covenants and agreements herein contained, the parties hereto agree as follows:

I.
SUPERSEDING EFFECT

This Agreement supersedes all prior oral or written Agreements, if any, between the parties and constitutes the entire Agreement between the parties relative to the work to be performed under this Agreement. Any changes or modifications to this Agreement shall be accomplished solely by written amendment signed by both parties.

II.
SCOPE OF SERVICES

Contractor shall provide RTA with Audit & Financial Oversight Services, in accordance with the terms and conditions set forth in Exhibit "A", Exhibit "B", and Exhibit "C". Contractor agrees that all goods and services under this Agreement shall be delivered in a professional, timely manner and shall conform to or exceed in all respects the prevailing industry standards.

III.
COMPENSATION

The RTA will compensate Contractor for the goods to be provided under this Agreement, as specified in this agreement and pursuant to Exhibit "A". The compensation due Contractor shall not exceed \$710,600.00 unless properly authorized.

IV.
TERM OF AGREEMENT

This Agreement shall be deemed effective on the date first above written and shall continue in effect until all items have been delivered or until the occurrence of one of the following events, occurs:

A. The certification by RTA or its agents that the requirements of this Agreement have been satisfactorily completed by Contractor, or;

B. The termination of this Agreement as provided in Article V, herein below. The duration of this agreement may be extended by mutual agreement of the parties.

V.
TERMINATION

Termination under this Agreement shall be in accordance with Exhibit "A", Article II, General Provisions, Paragraph 2.6, Termination; Section A – Termination for Convenience and Section B – Termination for Default of the Regional Transit Authority General Provisions.

VI.
INTEREST OF CONTRACTOR

Contractor covenants that it currently has no interest and shall acquire no interest, direct or indirect, which would conflict in any manner or degree with the delivery of the goods called for under this Agreement. RTA and Contractor further covenant that in the performance of this Agreement no persons having any such interest shall be employed.

VII.
IDENTIFICATION OF DOCUMENTS

Any document, memorandum or report prepared under this Agreement for publication and not merely for internal use shall contain the following or a similar stipulation deemed acceptable to the RTA:

- A. The preparation of this document has been financed in part through RTA operating funds. The RTA is a recipient of grant funds from the United States Department of Transportation under the provisions of the Urban Mass Transportation Act of 1964, as amended.
- B. The opinions, findings, and conclusions expressed in this publication are those of the author and not necessarily those of RTA or the United States Department of Transportation, Federal Transit Administration.

VIII.
OWNERSHIP OF DOCUMENTS

All documents, reports or data generated by or provided to Contractor under this Agreement shall be the sole property of RTA for a period of up to three years after acceptance of the goods. Contractor shall not use any such documents, reports or data for any purpose other than to perform services pursuant to this Agreement.

IX.
MEDIA COVERAGE

The Contractor shall be prohibited from participating in or directing any third party media coverage, in any form, of this project without first submitting a written request to RTA's Procurement representative noted in Article XI of this contract and receiving written approval from the same in advance of any such coverage.

X.
APPLICABLE LAW

This Agreement shall be entered into the State of Louisiana and shall be governed and/or construed in accordance with the laws and jurisprudence of the State of Louisiana.

XI.
NOTICES

Any notice required or permitted under the Agreement shall be either hand delivered to the party to whom the notice is directed or sent to same by certified mail, return receipt requested, and addressed as follows:

A. REGIONAL TRANSIT AUTHORITY
2817 Canal St.
New Orleans, Louisiana 70119

ATTN:

Mark Major
Chief Financial Officer-RTA

XII. DOCUMENTS INCORPORATED BY REFERENCE

The following documents are hereby incorporated by reference:

EXHIBIT "A" RTA Request for Quote (RFQ 2019-021), as amended.

EXHIBIT "B" Bid Submittal by Contractor dated, August 21, 2019.

EXHIBIT "C" FTA Clauses

XIII. ORDER OF PRECEDENCE

The following order of precedence shall govern in the event of a conflict between documents of this contract.

Articles I through XV hereof.

Exhibit "A", RTA RFQ No. 2019-021.

Exhibit "B" Contractor's Bid submittal in response to RTA's RFQ No. 2019-021, dated August 21, 2019.

Exhibit "C" FTA Clauses

XIV. INSURANCE

To protect RTA and Transdev against liability in connection with, or resulting from the carrying out of this contract, Contractor shall provide, before the work is commenced hereunder, and shall at all time during the life of the contract carry at the expense of the Contractor, with a reliable insurance company, and approved to do business in the State of Louisiana, all insurance required by local, state or federal laws should there be any such requirement(s). Any subcontractor employed by the Contractor shall be governed by the same insurance requirements as stated herein. The Contractor shall deliver to RTA a Certificate of Insurance when required.

During the term of this Agreement the Contractor shall obtain and maintain the following types and amounts of insurance. The Contractor shall furnish to RTA Certificates showing types, amounts, class of operations covered, effective dates and dates of expiration of policies:

- Worker's Compensation Insurance as required by applicable Louisiana Law.
- Vehicle Liability Insurance in the amount of \$1,000,000.00.
- General Liability Insurance in the amount of \$1,000,000.00.

XV. DBE COMPLIANCE

RTA in accordance with 49 Code of Federal Regulations (CFR) Part 26 has an obligation to ensure nondiscrimination of Disadvantaged Business Enterprises (DBEs) and to comply with all federal, state and local regulations relative to utilization of DBEs on publicly funded projects. The RTA is committed to utilization of DBEs on all federally funded projects toward attainment of the agency's established overall goal of 30%. A DBE goal of 28.44% was established for this project.

Notice to all offerors is hereby provided that in accordance with all applicable federal, state and local laws the RTA will ensure that DBEs are afforded full opportunity to submit offers and responses to this solicitation and to participate in any contract consummated pursuant

to this advertisement. Additionally, no offeror will be discriminated against on the basis of age, sex, race, color, religion, national origin, ethnicity or disability. **As such, award of the contract will be conditioned on meeting the requirements of the federal, state and local laws for Equal Opportunity including compliance with the policies of DBE Program.**

IN WITNESS WHEREOF, the parties have executed this Agreement in duplicate originals in the presence of the undersigned competent witnesses.

ATTEST:

BY:

REGIONAL TRANSIT AUTHORITY

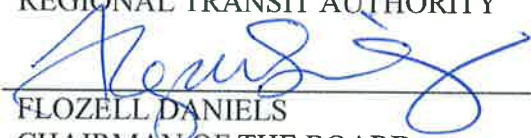

FLOZELL DANIELS
CHAIRMAN OF THE BOARD
OF COMMISSIONERS

ATTEST:

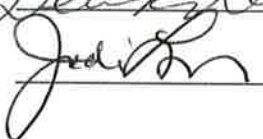
 Denise Robinson
 Judith Lane
BY:

REBECCA HAMMOND
AUTHORIZED OFFICER OF
CARR, RIGGS, & INGRAM, LLC

**Certification by Officer of
CARR, RIGGS, & INGRAM, LLC**

Approved as to legal form and adequacy and as to the authorization of the signatory
hereto on behalf of CARR, RIGGS, & INGRAM, LLC, on the date herein above shown.

Dated this 27th day of January, 2020.



Signature

Partner

Title

ACKNOWLEDGMENT

STATE OF LA

PARISH/COUNTY OF Jefferson

ON THIS 27 day of Jan, 2020 before me, Rebecca Hammond appeared, to me personally known; who being by me duly sworn, did say that she is the CPA PARTNER of CARR, RIGGS, & INGRAM, LLC and that this Agreement was signed on behalf of said Corporation by authority of its CPA PARTNER, Rebecca Hammond by said appearer acknowledged said instrument to be the free act and deed of Rebecca Hammond.

IN WITNESS WHEREOF I have hereunto set my official hand and seal on the date above written.

Kathleen R. Oldendorf
NOTARY PUBLIC IN AND FOR

PARISH (COUNTY), STATE

Kathleen R Oldendorf
Notary Public #83772
Commission Expires at Death
Parish of Orleans, LA



New Orleans Regional Transit Authority

2817 Canal Street
New Orleans, LA 70119

Board Report and Staff Summary

File #: 25-035

Finance Committee

[03.13.25 Fin Committee Meeting PowerPoint Presentation]



March 13, 2025

Regional Transit Authority

Finance Committee



The New Orleans Regional Transit Authority (RTA) hereby declares that, in accordance with La. R.S. 42:17.1 (A)(2)(a)-(c), a meeting will be held on Thursday, March 13, 2025, at 11:00 a.m. The agency's website streams the in-person meeting live, and mask-wearing is encouraged inside the boardroom.

This meeting is accessible to persons with disabilities. To help assure availability, modifications or accommodations linked to a disability must be requested 72 hours before the meeting or hearing. Please direct requests for public meeting accommodations to the Office of Board Affairs, 2817 Canal Street, NOLA 70119, or call 504-827-8341 or by email (rtaboard@rtaforward.org).



Written comments on any matter included on the agenda will be accepted in the following ways: 1) Submission of a Speaker Card on meeting day; 2) Electronically by email sent to: rtaboard@rtaforward.org prior to the meeting; or 3) By U.S. Mail send to 2817 Canal Street, Attention: Office of Board Affairs, New Orleans, LA 70119.



Agenda

- 1. Call to Order**
- 2. Roll Call**



Agenda

3. Consideration of Meeting Minutes

[Finance Meeting Minutes – February 13, 2025]

25-029



Agenda

4. Committee Chairman's Report



Agenda

5. Chief Executive Officer's Report



Agenda

6. Chief Financial Officer's Report

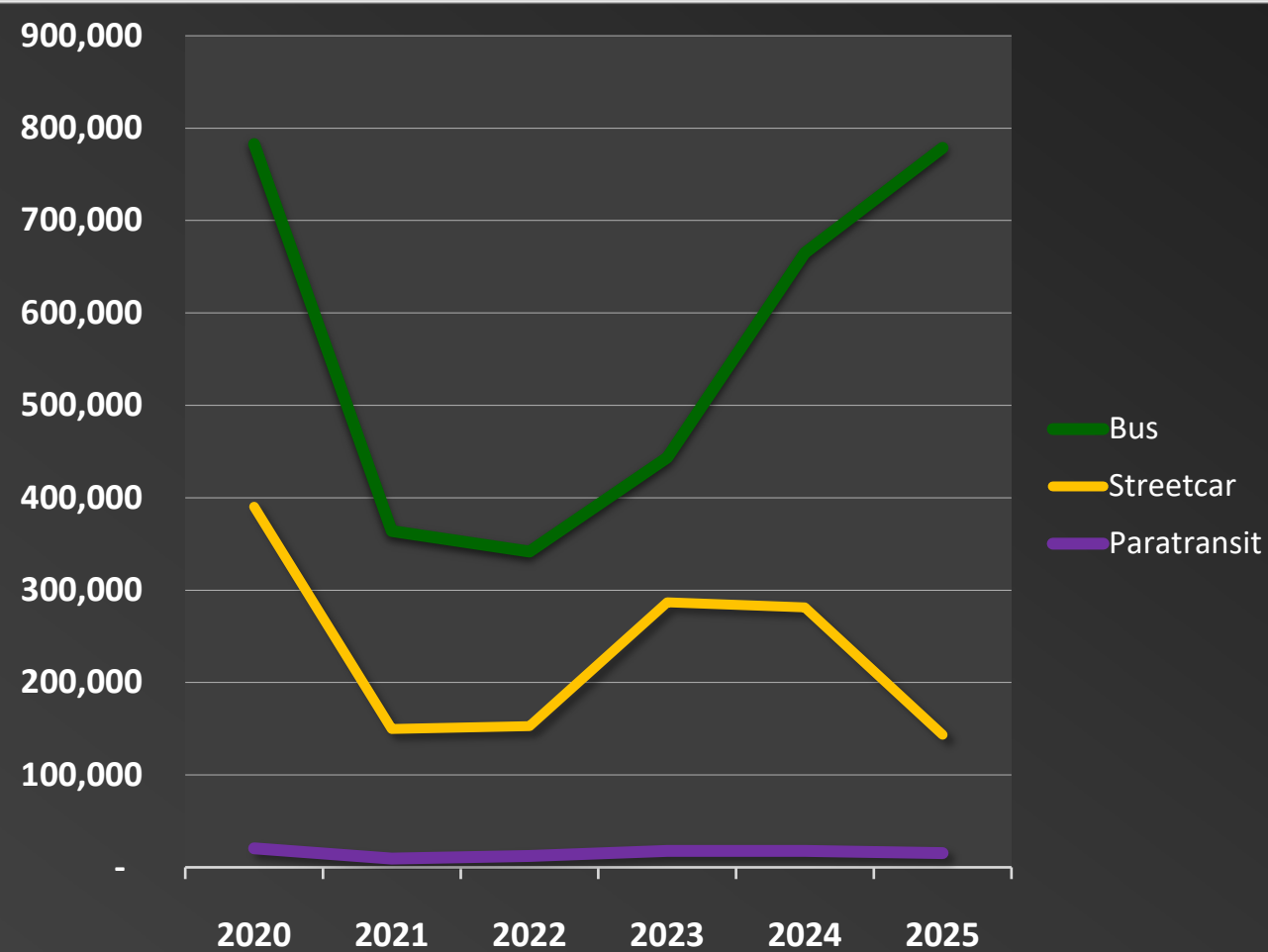
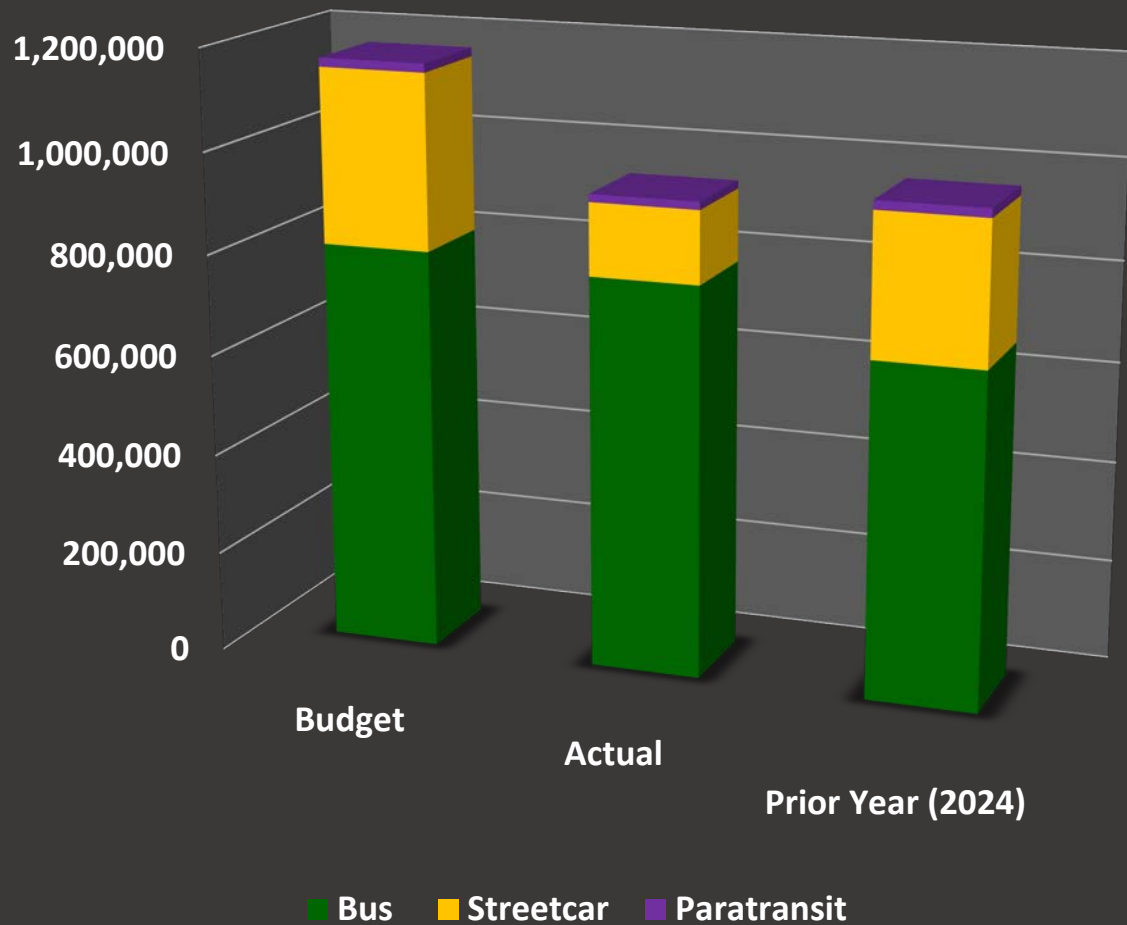

Ridership

Ridership in January decreased by 18.5% when compared to December 2024 actuals. In January, total system ridership (bus, streetcar and paratransit) was 938K, compared to 1.2M for the previous month of December.

FAREBOX RECOVERY RATES 2025 vs 2024

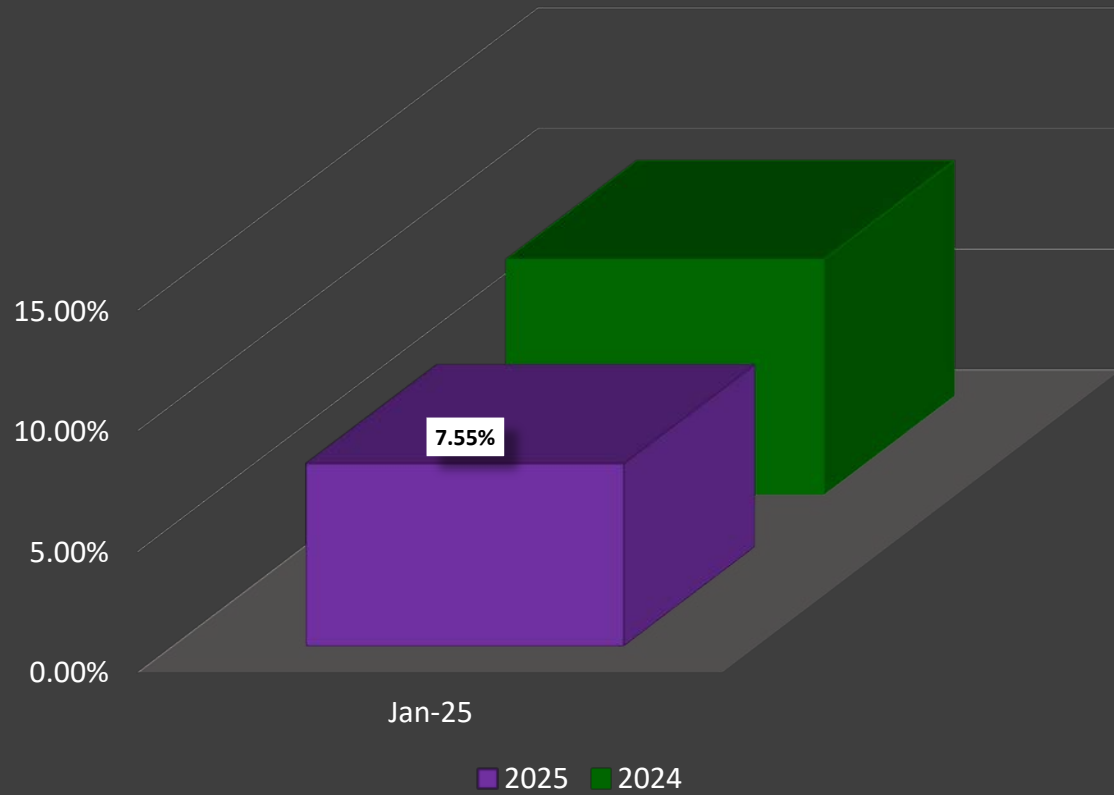

TOTAL OPERATING EXPENSES, FAREBOX REVENUE & FAREBOX RECOVERY

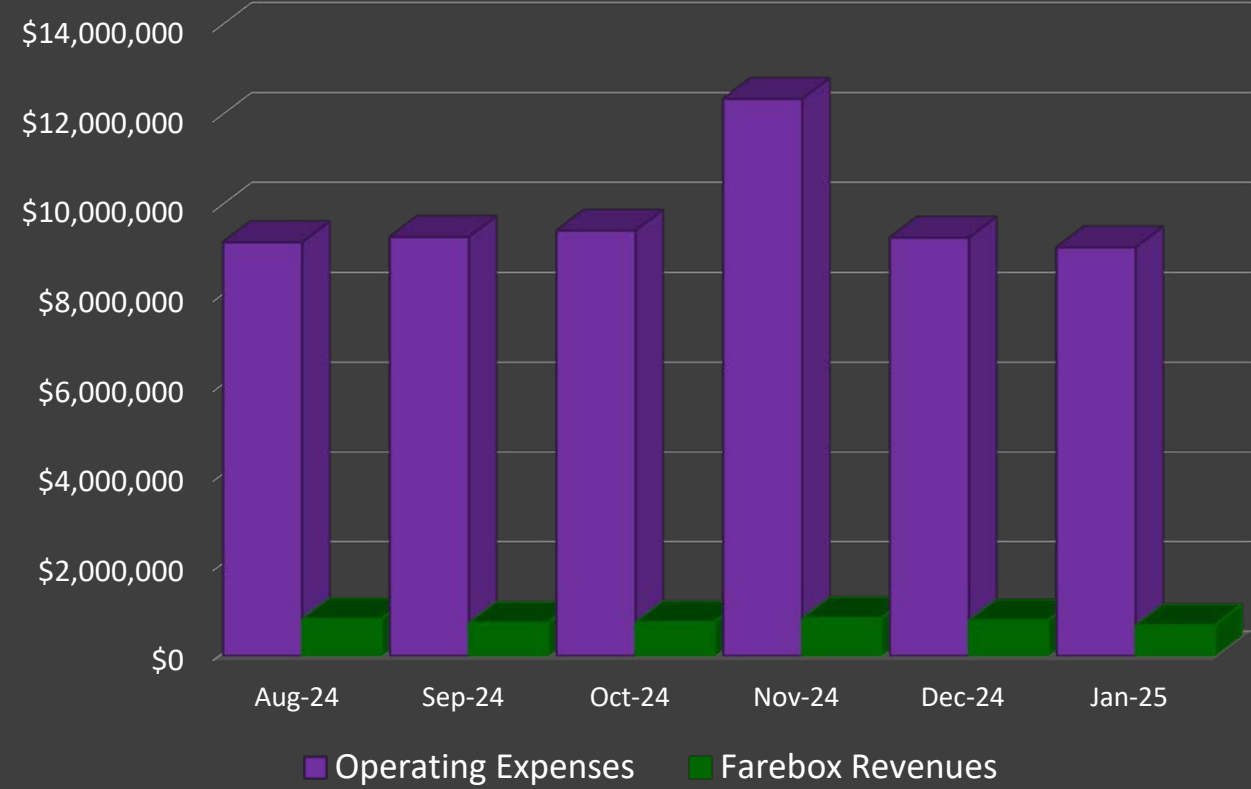

Farebox Recovery Rates 2025 vs. 2024

Fare revenue continues to offset a modest percentage of operating expenses as ridership continues to rebound. January's farebox recovery rate decreased from 8.5% to 7.6%, a decrease of 0.9%



FAREBOX RECOVERY RATES 2025 vs 2024

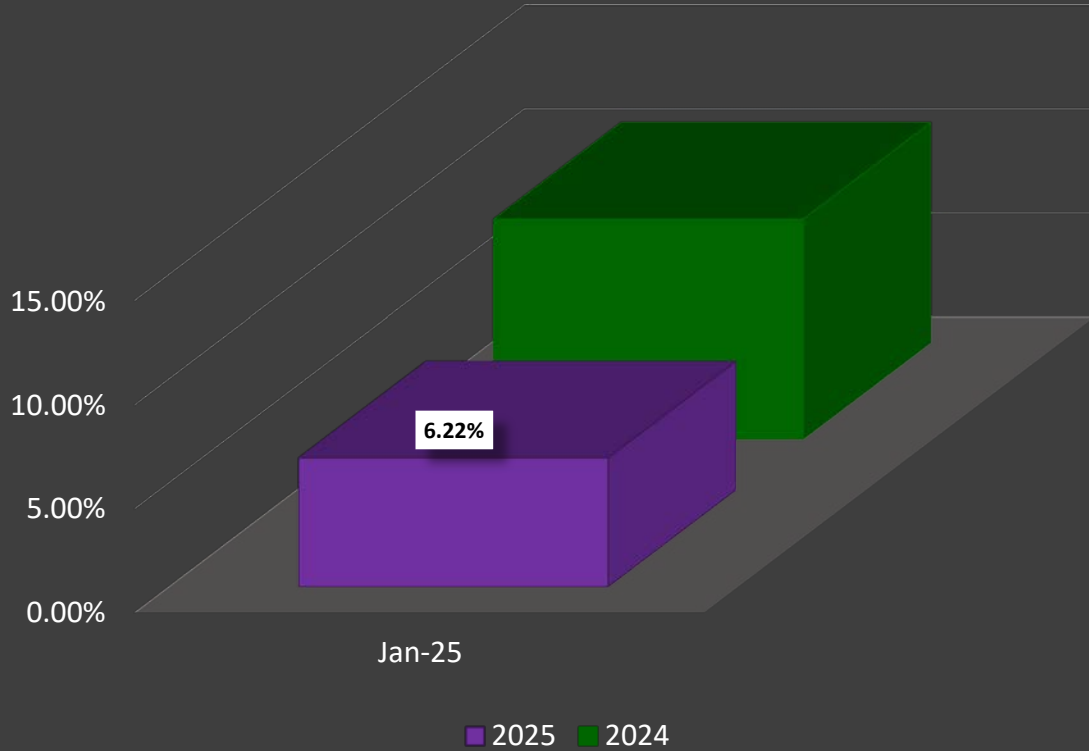

TOTAL OPERATING EXPENSES, FAREBOX REVENUE & FAREBOX RECOVERY

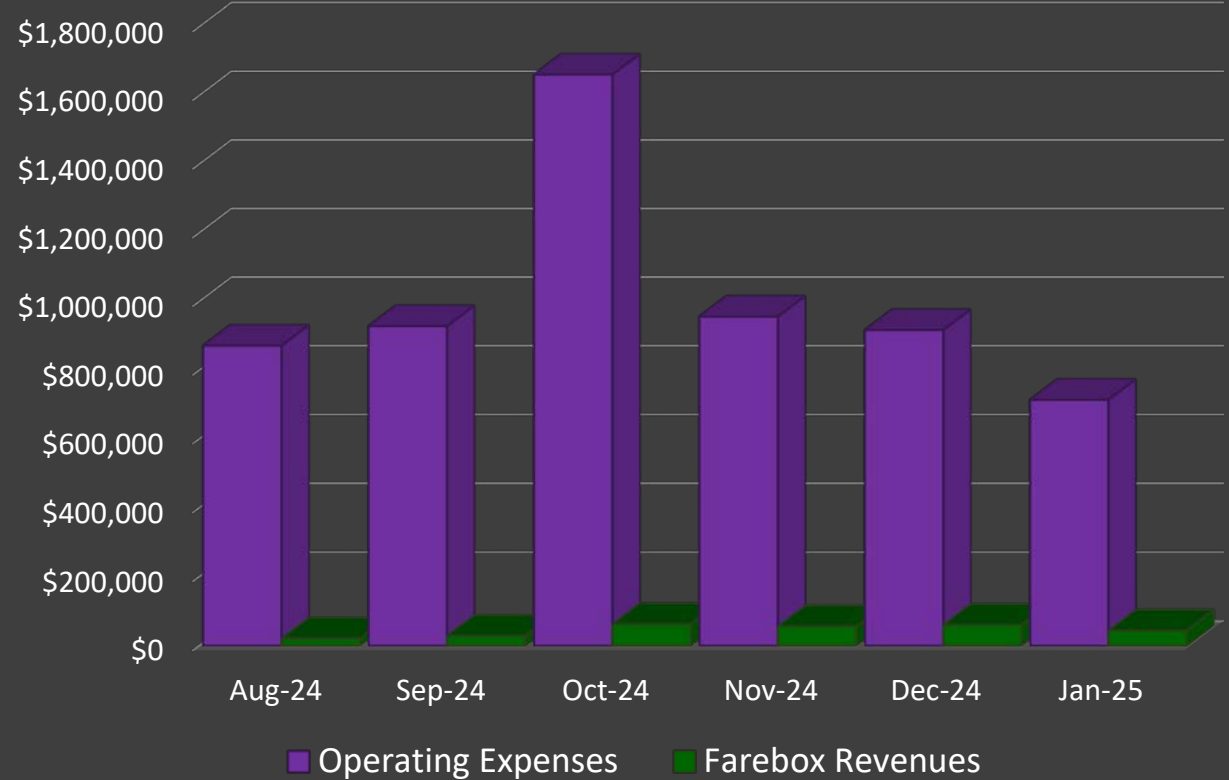

FERRY- Farebox Recovery Rates 2025 vs. 2024

The decrease in farebox recovery to 6.2% in January from 6.7% in December is the result of a decrease in operating expenses and a decrease in fare revenues from the prior month. Fare revenues continue to offset a small percentage of operating costs.





January 2025 Summary of Sources

SUMMARY OF SOURCES						
	Budget	Actuals	\$ Change	% Change	YTD Budget	YTD Actuals
Sales Tax	9,162,760	9,733,055	570,295	6.22%	9,162,760	9,733,055
Government Assistance	2,342,727	1,743,253	(599,474)	-25.59%	2,342,727	1,743,253
Sales Tax and Government Assistance	11,505,487	11,476,308	(29,179)	-0.25%	11,505,487	11,476,308
Passenger Fares	992,203	687,523	(304,680)	-30.71%	992,203	687,523
Other Operating Revenues	221,190	172,349	(48,841)	-22.08%	221,190	172,349
Subtotal Transit Operations	1,213,393	859,872	(353,521)	-29.13%	1,213,393	859,872
Total Operating Revenues	12,718,880	12,336,180	(382,700)	-3.01%	12,718,880	12,336,180
Capital Funding	5,275,772	2,672,598	(2,603,174)	-49.34%	5,275,772	2,672,598
Investment Income	131,239	103,041	(28,198)	100.00%	131,239	103,041
Subtotal Capital and Bond Resources	5,407,011	2,775,639	(2,631,372)	-48.67%	5,407,011	2,775,639
Total Revenue	18,125,891	15,111,819	(3,014,072)	-16.63%	18,125,891	15,111,819
Operating Reserve	0	2,148,312	2,148,312	-100.00%	0	2,148,312
Total Sources	18,125,891	17,260,131	(865,760)	-4.78%	18,125,891	17,260,131

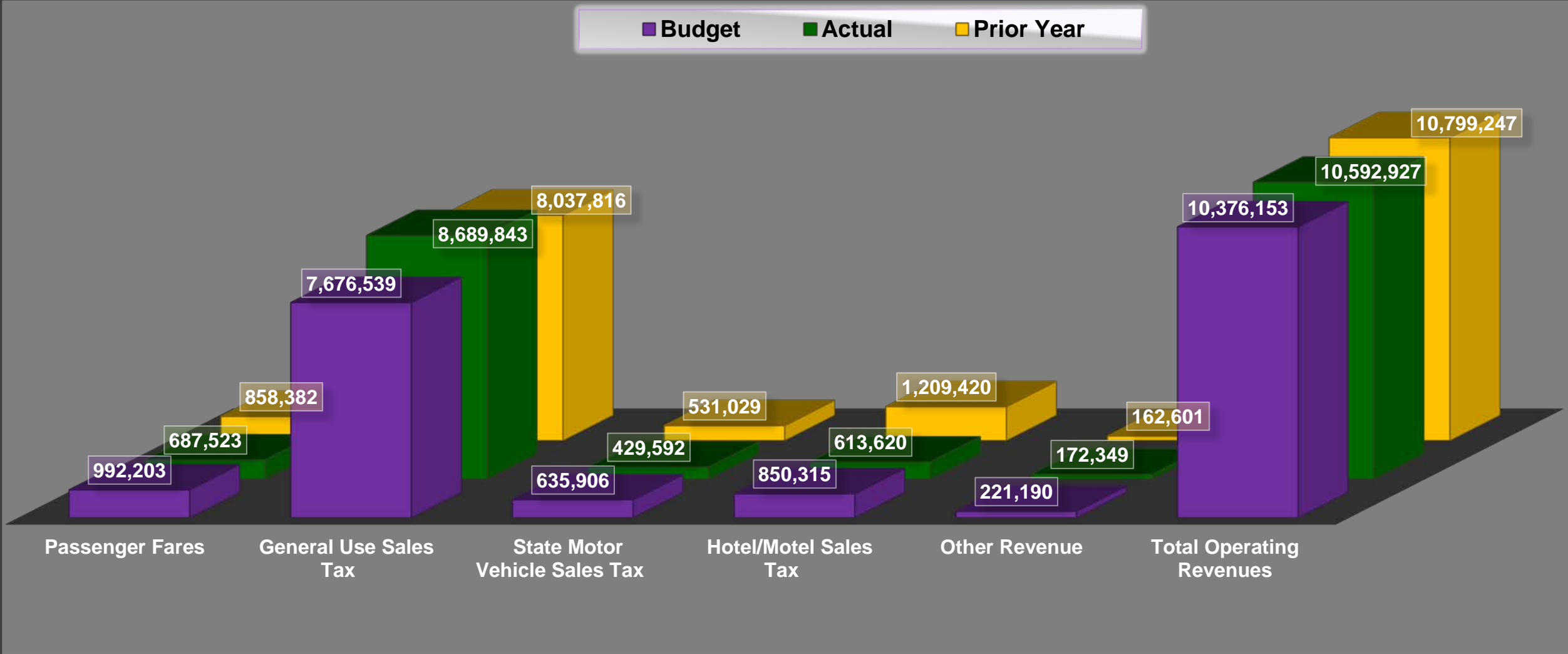

Operating Revenues (Budget, Actual & Prior Year)

RTA's two largest revenue sources are General Use Sales Tax (\$8.7M) and Passenger Fares (\$688K). The two combined make up 88.5% or \$9.4M of total revenue. Overall, total operating revenues for the month of January are \$10.6M.



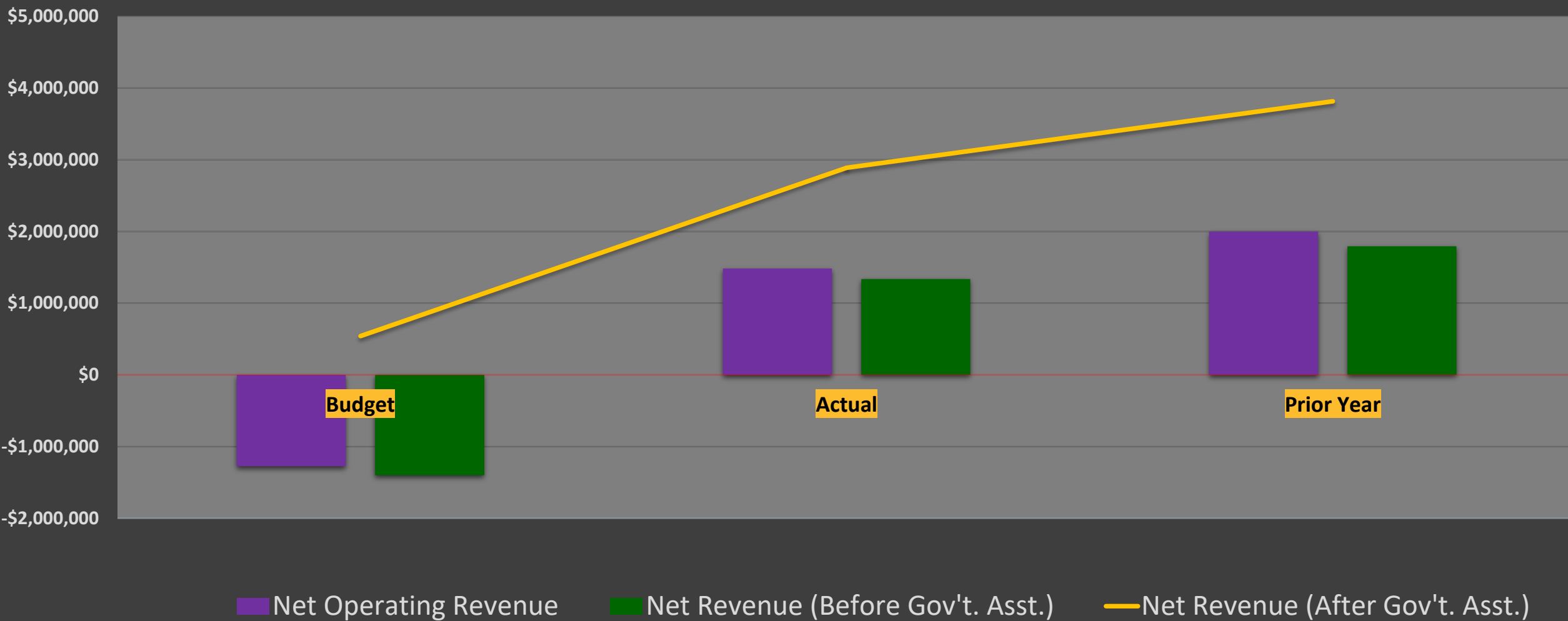

Net Revenues (Before and After Government Assistance)

Net Revenue (Before Government Assistance) is \$1.3M for the month of January. After applying the month's \$1.7M in Government Operating Assistance, Net Revenue is \$2.9M for the month of January.



January 2025 Summary of Uses

Summary of Uses						
	Budget	Actuals	\$ Change	% Change	YTD Budget	YTD Actuals
Transit Operations	11,649,552	9,109,342	2,540,210	21.81%	11,649,552	9,109,342
TMSEL Legacy Costs	126,694	147,374	(20,680)	-16.32%	126,694	147,374
Maritime Costs	401,915	191,359	210,556	0.00%	401,915	191,359
Capital Expenditures	5,275,772	2,672,598	2,603,174	49.34%	5,275,772	2,672,598
FEMA Project Worksheet Expenditures	0	0	0	0.00%	0	0
Debt Service	671,958	5,139,458	(4,467,500)	-664.85%	671,958	5,139,458
Total Expenditures	18,125,891	17,260,131	865,760	4.78%	18,125,891	17,260,131
Operating Reserve	0	0	0	0.00%	0	0
Total Uses	18,125,891	17,260,131	865,760	4.78%	18,125,891	17,260,131

Operating Expenses (Actual - \$9,109,342)

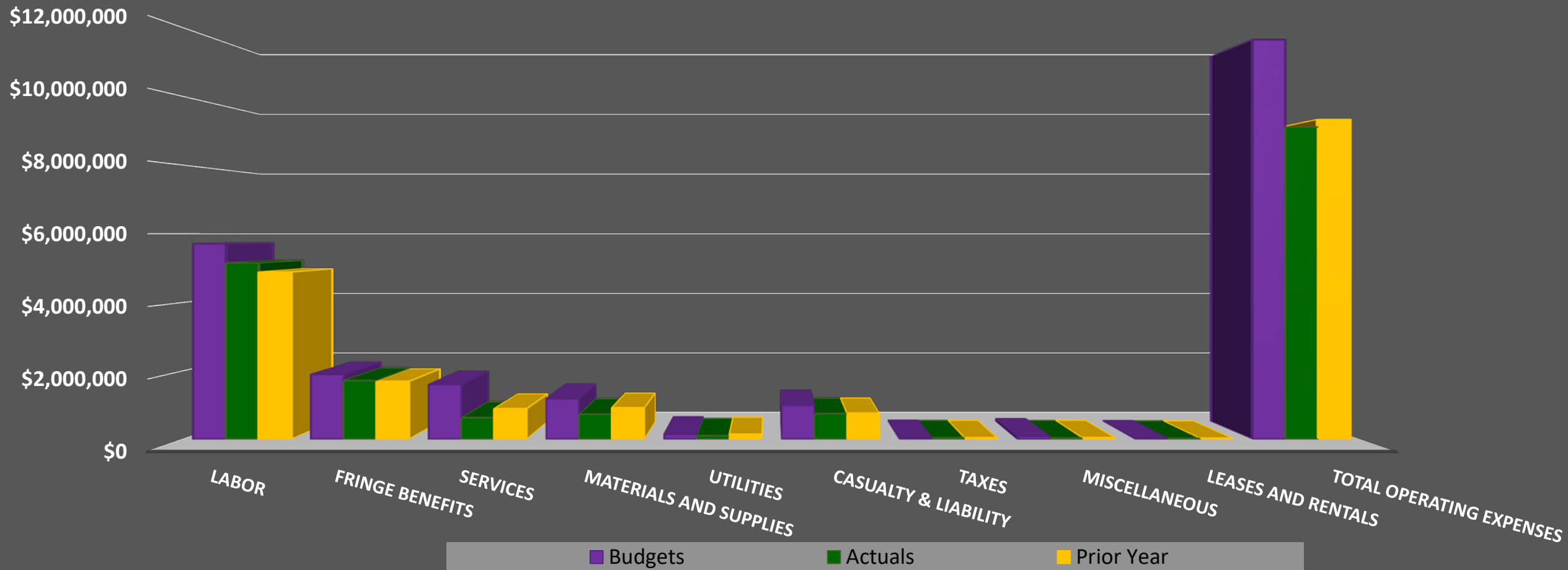

Operating Expenses

Operating Expenses for the month of January are roughly \$9.1M. Labor and Fringe Benefits, the largest expenditure at \$6.9M, comprised 75.3% of this month's actual expenses. In total, Operating Expenses for the month of January show a decrease of 2.3% from \$9.3M in December.



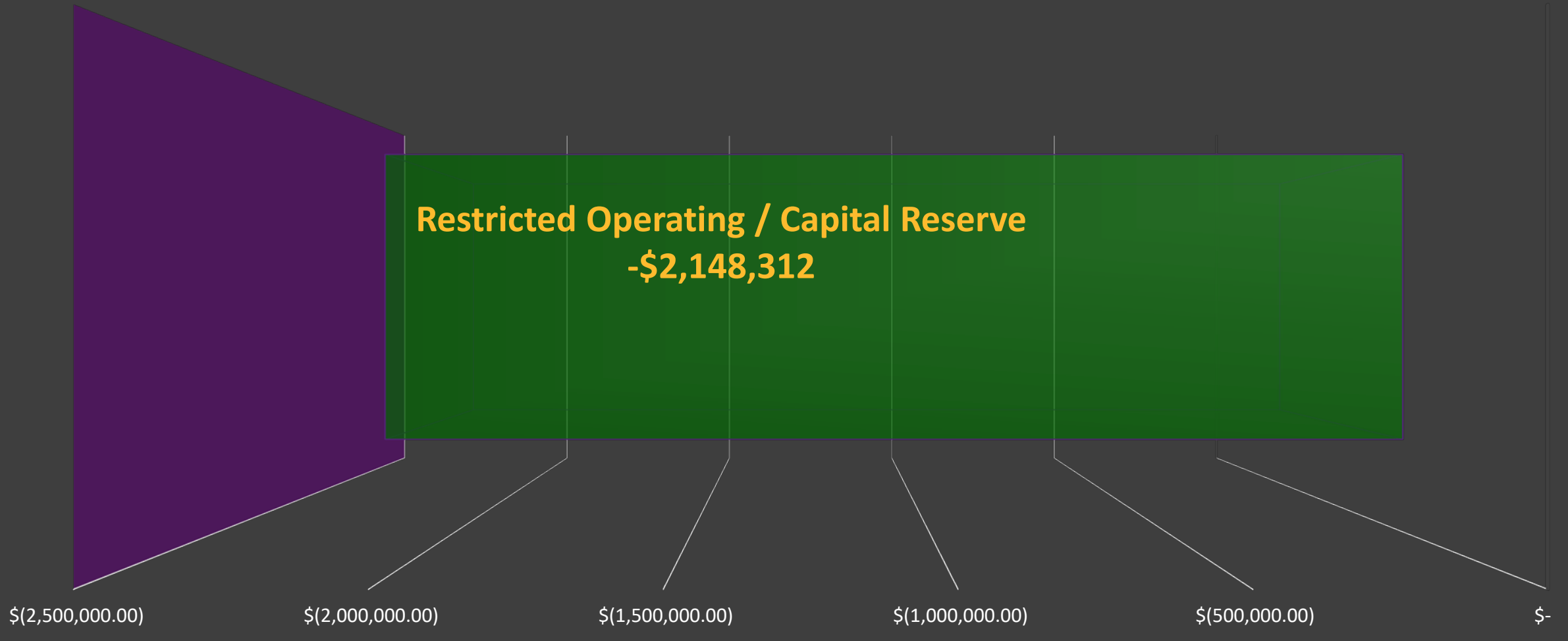

Operating Reserve

The negative variance that resulted from Net Revenue (After Government Assistance of approximately \$1.7M) reduced the Restricted Operating/Capital Reserve by \$2.1M, after the offset of \$5.1M in Debt Service.



Procurement

Purchase Orders Less than \$100K
(February 1, 2025 – February 28, 2025)

Order	Supplier	Cost Center Code	Cost Center Description	Account	Creation Date	Description	Purchase Order Amount
RTAP_01182	CARASOFT TECHNOLOGY CORP.	7500	Budget	01-7500-02-7080-171-89-00-00000-00000	2/4/25	Software License/Training	\$25,097.15
RTAP_01183	SEON SYSTEMS SALES INC	2900	Information Technology	01-2900-02-7140-161-00-00-00000-00000	2/4/25	2024 Commander License Annual Renewal - 280 Vehicles	\$19,040.00
RTAP_01184	DIXIE INDUSTRIES INC	4300	Maintenance	01-4300-04-8510-061-03-00-00000-00000	2/4/25	Materials & Supplies	\$1,892.00
RTAP_01186	EVERON LLC	2843	Facility Maintenance	01-2843-99-7670-124-00-00-00000-00000	2/5/25	Emergency Repair Sprinkler Drain System	\$3,127.78
RTAP_01187	JR CHEMICAL SALES	4300	Maintenance	01-4300-99-8620-124-00-00-00000-00000	2/5/25	Degreaser	\$410.24
RTAP_01188	JOHN HENRY ENTERPRISES IN	2843	Facility Maintenance	01-2843-99-8620-123-01-00-00000-00000	2/5/25	Materials & Supplies	\$136.00
RTAP_01189	TRI-STATE REFRIGERATION	4300	Maintenance	01-4300-02-7410-061-01-00-00000-00000	2/5/25	Vehicle Repairs And Parts	\$2,020.10
RTAP_01190	KENWORTH OF LOUISIANA LLC	4300	Maintenance	01-4300-02-7360-061-01-00-00000-00000	2/5/25	Vehicle Repairs And Parts	\$4,541.41
RTAP_01191	NU-LITE ELECTRICAL WHOLESALERS	2843	Facility Maintenance	01-2843-99-8620-123-01-00-00000-00000	2/5/25	Materials & Supplies	\$1,061.93
RTAP_01192	SIEMENS INDUSTRY, INC	2843	Facility Maintenance	01-2843-99-7610-127-89-00-00000-00000	2/5/25	Building Repairs And Parts	\$2,674.00
RTAP_01193	CCS INDUSTRIAL SERVICES INC	2843	Facility Maintenance	01-2843-99-7610-127-89-00-00000-00000	2/5/25	Building Repairs And Parts	\$850.00
RTAP_01194	M S BENBOW AND ASSOCIATES	2900	Information Technology	01-2900-02-7140-171-00-00-00000-00000	2/5/25	Software License/Training	\$700.00
RTAP_01195	BROAD AUTO GLASS	2843	Facility Maintenance	01-2843-99-7610-127-89-00-00000-00000	2/5/25	Building Repairs And Parts	\$2,899.67
RTAP_01196	NEW FLYER OF AMERICA	4300	Maintenance	01-4300-02-8510-062-01-00-00000-00000	2/6/25	Materials & Supplies	\$480.16
RTAP_01197	AIRGAS GULF STATES (USE VONDOR #1361793)	4300	Maintenance	01-4300-04-8640-061-03-00-00000-00000	2/6/25	Airgas Cylinder Rental	\$7,640.12
RTAP_01198	TRAPEZE SOFTWARE INC	2900	Information Technology	01-2900-02-7140-012-13-00-00000-00000	2/6/25	Here - Software Update For Fleet Map	\$23,145.00
RTAP_01199	MODEL1	4500	Paratransit Services	01-4500-06-7490-061-05-00-00000-00000	2/6/25	Glass Door (#7415)	\$356.88
RTAP_01200	SEON SYSTEMS SALES INC	2900	Information Technology	01-2900-02-7140-161-00-00-00000-00000	2/6/25	2024 Commander License Annual Renewal - 280 Vehicles	\$19,040.00
RTAP_01201	AMERICAN TRACTION SYSTEMS INC	4300	Maintenance	01-4300-16-8510-061-03-00-00000-00000	2/7/25	Materials & Supplies	\$12,600.00
RTAP_01203	KEN BROWN & SONS, INC.	2843	Facility Maintenance	01-2843-99-8620-125-00-00-00000-00000	2/7/25	Backflow Repair (French Market Bathroom)	\$547.88
RTAP_01204	AIR NU INC	2843	Facility Maintenance	01-2843-99-8620-125-00-00-00000-00000	2/7/25	Materials & Supplies	\$2,511.50
RTAP_01205	GRAINGER (2)	2843	Facility Maintenance	01-2843-99-8620-125-00-00-00000-00000	2/7/25	Ceiling Tiles	\$1,832.20
RTAP_01206	SOUTHEAST SAFETY & SUPPLY CO	2843	Facility Maintenance	01-2843-99-8640-166-00-00-00000-00000	2/7/25	Chemical Pads	\$1,239.00
RTAP_01207	TRANE US INC	2843	Facility Maintenance	01-2843-99-7610-127-89-00-00000-00000	2/7/25	Compressor Repair (It Computer Room)	\$3,329.00
RTAP_01208	GRAINGER (2)	4300	Maintenance	01-4300-06-8640-091-00-00-00000-00000	2/7/25	Pocket Hole Machine	\$621.10
RTAP_01209	VAUGHN'S POWER EQUIPMENT INC	4300	Maintenance	01-4300-16-8640-121-03-00-00000-00000	2/7/25	Ground Materials (Oil, Weed Eater, &Gatorline)	\$2,076.00



Procurement

Purchase Orders Less than \$100K
(February 1, 2025 – February 28, 2025)

Order	Supplier	Cost Center Code	Cost Center Description	Account	Creation Date	Description	Purchase Order Amount
RTAP_01210	SHERWIN-WILLIAMS	4300	Maintenance	01-4300-99-8640-166-03-00-00000-00000	2/7/25	Materials & Supplies	\$314.85
RTAP_01211	ULINE INC	4300	Maintenance	01-4300-99-8640-166-03-00-00000-00000	2/7/25	Materials & Supplies	\$2,960.57
RTAP_01212	NAPA	4300	Maintenance	01-4300-99-8070-031-03-00-00000-00000	2/7/25	Vehicle Repairs And Parts	\$238.72
RTAP_01213	DELL MARKETING LP	2900	Information Technology	01-2900-02-8580-170-00-00-00000-00000	2/10/25	Computer Hardware	\$16,862.45
RTAP_01215	DIXIE INDUSTRIES INC	4300	Maintenance	01-4300-16-8510-061-03-00-00000-00000	2/10/25	Fuses For Storeroom	\$1,872.00
RTAP_01216	MODEL1	4500	Paratransit Services	01-4500-06-8510-061-05-00-00000-00000	2/10/25	Heater & Module	\$1,319.07
RTAP_01217	CDWG	2900	Information Technology	01-2900-02-8580-170-00-00-00000-00000	2/11/25	Computer Hardware & Software	\$7,962.21
RTAP_01218	SIGNVERSE LLC	4600	Safety and Claims	01-4600-02-8460-166-00-00-00000-00000	2/11/25	Physical Security Promo Items	\$3,239.00
RTAP_01220	NAPA (2)	4300	Maintenance	01-4300-06-8640-091-00-00-00000-00000	2/12/25	Bed Storage System	\$8,942.10
RTAP_01221	LOUISIANA OFFICE PRODUCTS	2843	Facility Maintenance	01-2843-99-8690-181-00-00-00000-00000	2/12/25	Conference Chairs	\$0.00
RTAP_01222	UNIVERSITY OF NEW ORLEANS LAKEFRONT CAMPUS	7700	Human Resources	01-7700-02-7181-167-00-00-00000-00000	2/12/25	Professional Services/Employment	\$29,233.00
RTAP_01223	JF PETROLEUM GROUP	2843	Facility Maintenance	01-2843-99-8640-125-00-00-00000-00000	2/13/25	Pump For Eno Motor Oil Tank	\$1,470.00
RTAP_01224	EDDIE'S ACE HARDWARE	4300	Maintenance	01-4300-99-8610-121-03-00-00000-00000	2/13/25	Blacktop Patches For Potholes	\$2,684.90
RTAP_01225	PEARL MEDIA	4300	Maintenance	01-4300-99-8610-121-03-00-00000-00000	2/13/25	Sand Bags	\$2,832.80
RTAP_01226	NU-LITE ELECTRICAL WHOLESALERS	2843	Facility Maintenance	01-2843-99-8620-123-01-00-00000-00000	2/17/25	Stem Conduit Mount Photocontrol Light Sensor	\$568.51
RTAP_01227	DIXIE INDUSTRIES INC	2843	Facility Maintenance	01-2843-99-8620-123-01-00-00000-00000	2/17/25	Steel Plates	\$889.00
RTAP_01143	GRAINGER (2)	4300	Maintenance	01-4300-05-8640-181-03-00-00000-00000	2/17/25	Bottled Water	\$1,320.00
RTAP_01228	JM TEST SYSTEMS INC	4300	Maintenance	01-4300-99-8640-141-03-00-00000-00000	2/17/25	Telescopic Fiberglass Hot Stick	\$2,301.00
RTAP_01229	NAPA	4300	Maintenance	01-4300-99-8640-124-00-00-00000-00000	2/17/25	Discs & Drum Pumps	\$2,650.00
RTAP_01230	GRAINGER (2)	4300	Maintenance	01-4300-16-8640-121-03-00-00000-00000	2/18/25	Sis Equipment Replacement	\$8,183.56
RTAP_01231	NEW FLYER OF AMERICA	4300	Maintenance	01-4300-02-8510-062-01-00-00000-00000	2/18/25	Repair Parts For Accident	\$6,997.66
RTAP_01232	LA WATERS	4300	Maintenance	01-4300-02-8650-061-01-00-00000-00000	2/18/25	Bottled Water	\$2,825.82
RTAP_01233	CARASOFT TECHNOLOGY CORP.	2900	Information Technology	01-2900-02-7140-163-00-00-00000-00000	2/18/25	Software License/Training	\$14,496.76
RTAP_01234	TRUCK AND TRANSPORTATION	4300	Maintenance	01-4300-06-7580-091-00-00-00000-00000	2/18/25	Vehicle Repairs And Parts	\$1,350.00
RTAP_01235	TRANE US INC	2843	Facility Maintenance	01-2843-06-7520-125-00-00-00000-00000	2/19/25	Chiller Maintenance (3 Years)	\$26,023.35
RTAP_01236	GENFARE (2)	2943	Information Technology	01-2943-02-8460-111-13-00-00000-00000	2/19/25	Genfare Farebox Replacement Parts	\$70,000.00
RTAP_01237	AIR NU INC	4300	Maintenance	01-0000-00-1302-000-00-00-00000-00000	2/19/25	Air Filters	\$388.80
RTAP_01238	CDWG	2900	Information Technology	01-0000-00-1517-000-00-00-00000-00000	2/19/25	Dji Drone Kit	\$9,184.48
RTAP_01239	GOODYEAR TIRE AND RUBBER COMPANY	4300	Maintenance	01-4300-06-8120-081-00-00-00000-00000	2/20/25	Backhole Front Tires	\$994.99
RTAP_01240	GRAINGER (2)	2843	Facility Maintenance	01-2843-99-8620-123-01-00-00000-00000	2/20/25	Materials & Supplies	\$1,174.322



Procurement

Purchase Orders Less than \$100K
(February 1, 2025 – February 28, 2025)

Order	Supplier	Cost Center Code	Cost Center Description	Account	Creation Date	Description	Purchase Order Amount
RTAP_01241	LAMARQUE FORD	4500	Paratransit Services	01-4500-06-7310-061-05-00-00000-00000	2/20/25	Vehicle Repairs And Parts	\$24,373.50
RTAP_01242	BLUEWATER RUBBER & GASKET COMPANY	4300	Maintenance	01-0000-00-1302-000-00-00-00000-00000	2/20/25	Vehicle Repairs And Parts	\$534.00
RTAP_01243	RELIABLE TRANSMISSION SER	4300	Maintenance	01-4300-02-7310-061-01-00-00000-00000	2/20/25	Vehicle Repairs And Parts	\$10,629.38
RTAP_01244	NEW FLYER OF AMERICA (2)	4300	Maintenance	01-4300-02-8510-062-01-00-00000-00000	2/21/25	Assy Panel Driver Overhead #327	\$1,990.50
RTAP_01245	KENWORTH OF LOUISIANA LLC	4300	Maintenance	01-4300-02-7310-061-01-00-00000-00000	2/21/25	Vehicle Repairs And Parts	\$16,106.64
RTAP_01246	THE HON COMPANY	2843	Facility Maintenance	01-2843-99-8690-181-00-00-00000-00000	2/21/25	Conference Chairs	\$6,287.85
RTAP_01247	BETSY ROSS FLAG GIRLS	2843	Facility Maintenance	01-2843-99-8620-125-00-00-00000-00000	2/24/25	Materials & Supplies	\$732.00
RTAP_01248	GRAINGER (2)	4300	Maintenance	01-4300-02-8640-051-01-00-00000-00000	2/24/25	Materials & Supplies	\$140.52
RTAP_01249	GRAINGER (2)	4300	Maintenance	01-4300-99-8640-061-03-00-00000-00000	2/24/25	Materials & Supplies	\$2,602.00
RTAP_01250	HILLER COMPANIES LLC, THE	4300	Maintenance	01-4300-02-7610-061-01-00-00000-00000	2/24/25	Vehicle Repairs And Parts	\$880.00
RTAP_01251	STAR LOCK & KEY COMPANY INC	4300	Maintenance	01-4300-99-7610-181-13-00-00000-00000	2/24/25	Materials & Supplies	\$1,765.00
RTAP_01252	CONVERGINT TECHNOLOGIES	2900	Information Technology	01-2900-02-7140-170-00-00-00000-00000	2/24/25	Building Repairs And Parts	\$5,130.35
RTAP_01253	DYNAMITE DUMPSTERS	7800	Administrative Services	01-7800-02-9771-181-00-00-00000-00000	2/25/25	Restroom Trailers	\$2,850.00
RTAP_01254	GRAINGER (2)	4300	Maintenance	01-4300-06-8640-121-03-00-00000-00000	2/25/25	Wood Shaper & Feeder	\$5,969.99
RTAP_01255	GRAINGER (2)	4300	Maintenance	01-4300-99-8510-061-03-00-00000-00000	2/25/25	Materials & Supplies (Nuts & Bolts)	\$10,742.73
RTAP_01256	FASTENAL COMPANY	4300	Maintenance	01-4300-02-8510-061-01-00-00000-00000	2/25/25	Various Materials & Supplies	\$8,836.22
RTAP_01257	TRANE US INC	2843	Facility Maintenance	01-2843-99-7570-125-00-00-00000-00000	2/25/25	Chiller Maintenance (3 Years) @ Canal	\$15,293.00
RTAP_01259	UNITED RENTALS	4300	Maintenance	01-4300-02-7610-061-01-00-00000-00000	2/26/25	Manlift Cylinder Repairs	\$4,181.94
RTAP_01260	GRAINGER (2)	2843	Facility Maintenance	01-2843-99-8620-125-00-00-00000-00000	2/26/25	Materials & Supplies	\$2,009.26
RTAP_01261	TRANE US INC	2843	Facility Maintenance	01-2843-99-7610-127-89-00-00000-00000	2/26/25	Building Repairs And Parts	\$19,983.00
RTAP_01262	NEW FLYER OF AMERICA	4300	Maintenance	01-4300-02-8510-062-01-00-00000-00000	2/26/25	Vehicle Repairs And Parts	\$5,413.98
RTAP_01263	4IMPRINT INC	7700	Human Resources	01-7700-02-9496-181-89-00-00000-00000	2/26/25	Printing Services	\$2,533.35
RTAP_01264	HOSE GUYS	4300	Maintenance	01-4300-02-8510-061-01-00-00000-00000	2/26/25	Hoses & Fittings	\$845.33
Total:							\$518,979.91





Questions?



Agenda

7. DBE Report



Contract Awards February 2025

\$760,203 in contracts were awarded

- \$50,000 was awarded to DBE firms.
- Of the DBE contracts \$50,000 was awarded to DBE/SBE Prime Contractors.

Total DBE participation (commitment) is 6%.

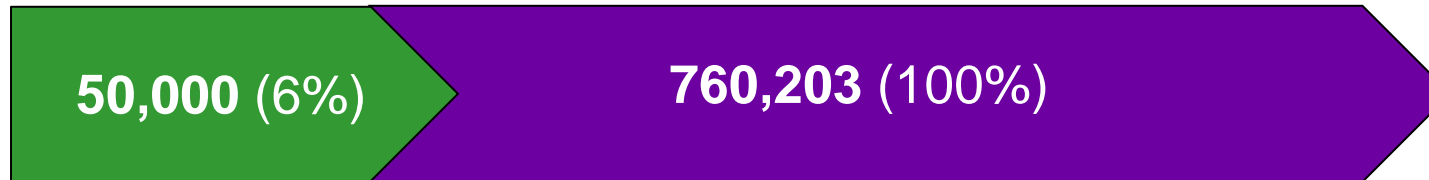

Current DBE Projects

Project	Contract Amount	DBE Goal	DBE Goal	% Goal Achieved	Tentative Completion Date
Disaster Recovery Grants Management and Administration	\$137,888	\$67,565	49%	39%	6/2025
Transit Ferry Services	\$8,442,843	\$842,442	10%	0%	1/2026
OSHA Program Development and Training	\$203,800	\$203,800	100%	61%	5/2026
Universal Accessibility Study	\$260,000	\$88,192	33.92%	0%	12/2025



Current DBE Projects

Project	Contract Amount	DBE Goal	DBE Goal	% Goal Achieved	Tentative Completion Date
On Call Technical Safety Support	\$545,572	\$545,572	100%	77%	11/2025
Drug and Alcohol Testing Services	\$95,000	\$95,000	100%	41%	9/2026

Contract Amount

DBE Goal

DBE Goal Achieved

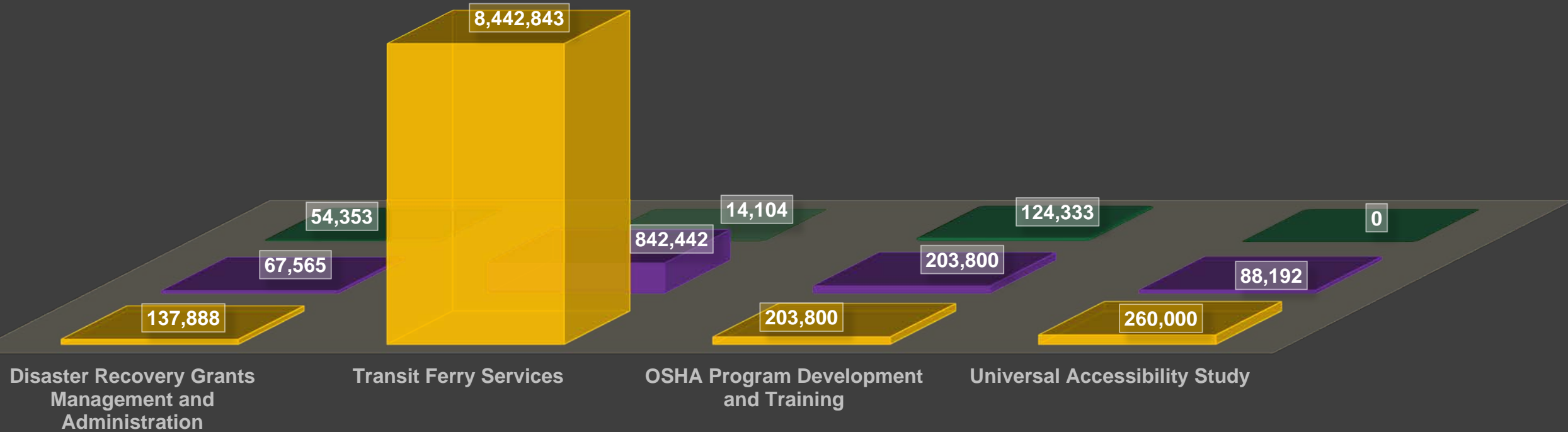

Current DBE Projects

Contract Amount

DBE Goal

DBE Goal Achieved

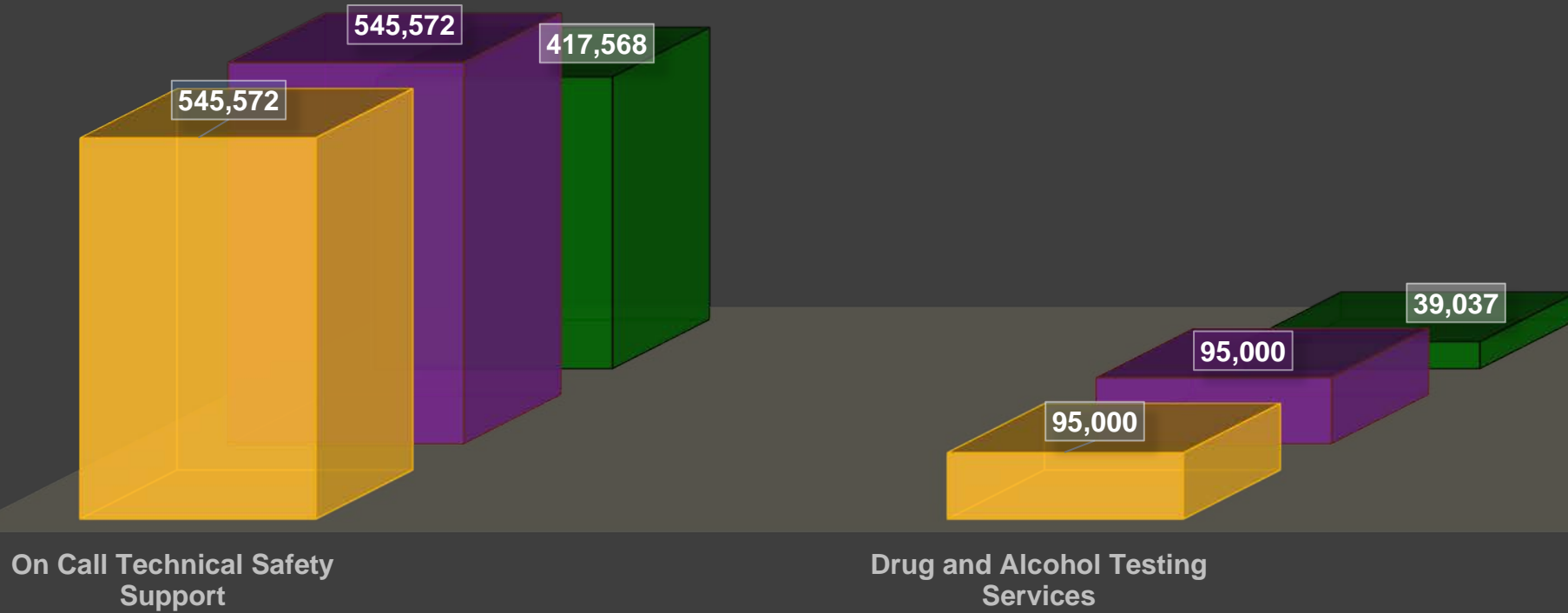

Current DBE Projects



Current SBE Projects

Project	Contract Amount	SBE Goal	SBE Goal	% Goal Achieved	Tentative Completion Date
Temporary Janitorial Services	\$1,928,000	\$1,928,000	100%	99%	3/2025
Advertising Campaigns & Media Buying Services	\$400,000	\$400,000	100%	57%	2/2028
Non-Advertisement Bus Shelters	\$832,148	\$832,148	100%	77%	3/2025
Algiers Ferry Buildings Renovation	\$1,100,000	\$1,100,000	100%	46%	3/2026
Website Services	\$300,000	\$300,000	100%	30%	5/2026



Current SBE Projects

Project	Contract Amount	SBE Goal	SBE Goal	% Goal Achieved	Tentative Completion Date
Facility Maintenance & Construction Support Services	\$1,362,506	\$1,362,506	100%	60%	12/2023
Algiers Ferry Barges Replacement	\$1,365,265	\$1,365,265	100%	1%	12/2025
Zero Emission Fleet Planning	\$150,000	\$150,000	100%	0%	5/2025
Transit Stops Inventory Improvement	\$493,430	\$493,430	100%	0%	1/2026

■ Contract Amount

■ SBE Goal

■ SBE Goal Achieved

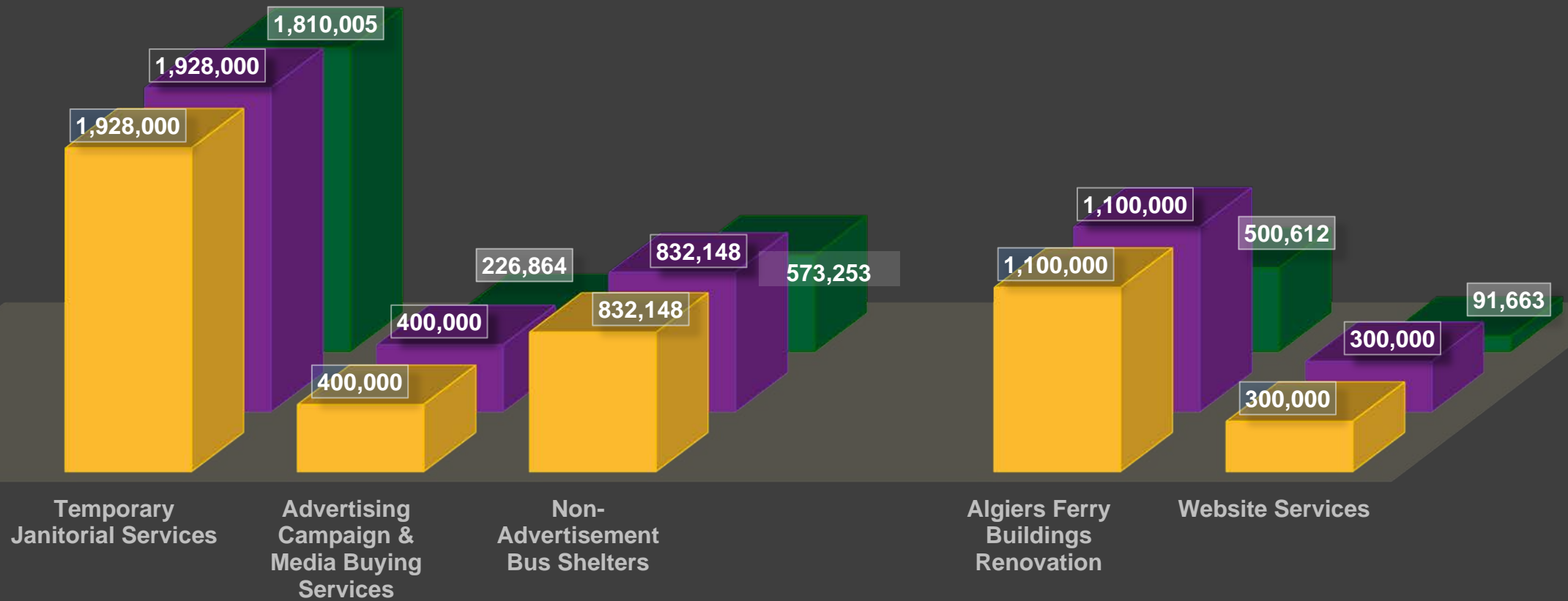

Current SBE Projects

■ Contract Amount

■ SBE Goal

■ SBE Goal Achieved

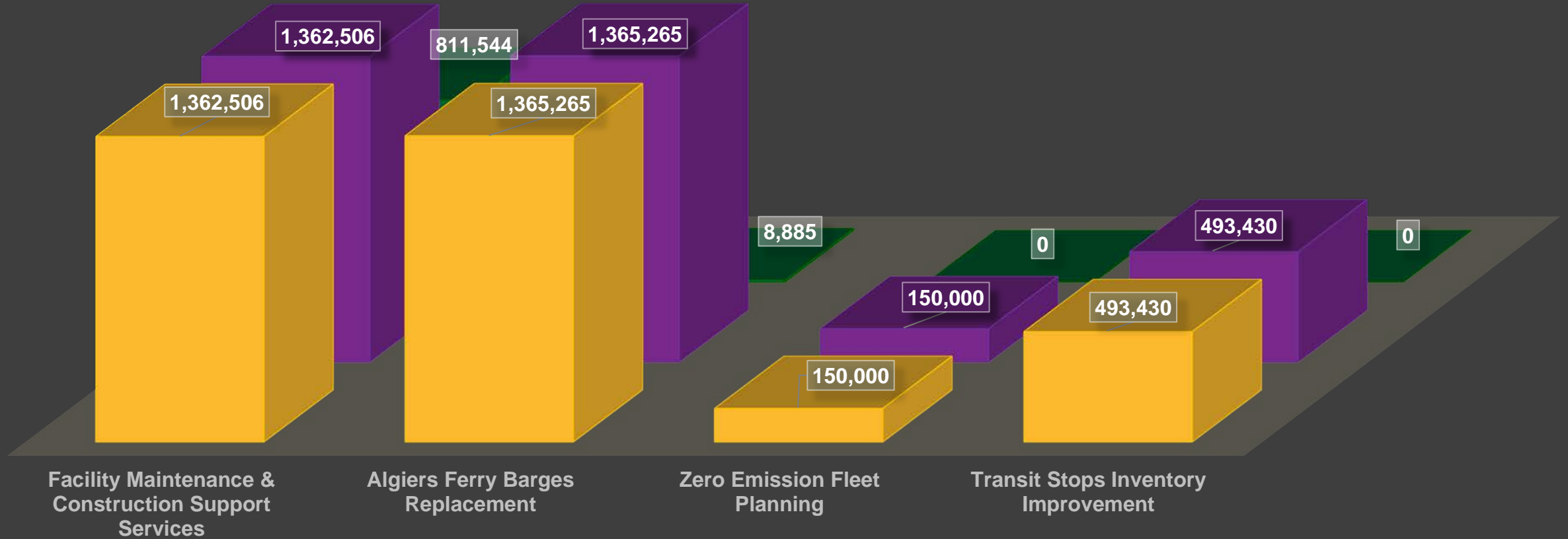

Current SBE Projects



Upcoming DBE/SBE Projects

DBE/SBE Goal

RFP 2024-012 Executive Coaching & Consultant Services
(To be awarded at April Board Meeting)

100% SBE

RFQ 2024-034 Climate Adaptive Transit Shelter Design
(Technical Evaluation date TBD)

18% DBE

RFP 2025-004 Exclusive Advertisement Rights
(Proposals due 3/10 by 1pm)

24.35% DBE

RFQ 2025-008 Standard Operating Procedure Development
(Proposals due 3/20 by 4pm)

34.61% DBE

RFQ 2025-009 Streetcar System Modernization Feasibility Study
(Proposals due 3/21 by 4pm)

32% DBE



DBE/SBE Business Development Trainings

DBE Workshop: How to Survive and Thrive the End of DEI Programs in Federal and Local Contracting

The learning objective of this workshop is to help certified small and disadvantaged business enterprise firms navigate and thrive the changing public sector contracting landscape.

Tuesday, March 25th 5:30 PM to 7:00 PM

RTA Board Room, 2nd Floor
2817 Canal Street, New Orleans



Questions?



Agenda

8. Chief Planning and Capital Project Officer's Report

Open Projects: Construction

2023 Shelter Installation

Contracting:

Engineer: Infinity

Contractor: Pivotal Engineering

Contracting Strategy: D/B/B

Project Costs:

Design: \$141,299

Construction: \$832,148

Status:

- All permits approved
- 12 of 16 sites completed
- 3 shelters installs this week underway;
- 1 delayed for water leak

Schedule:

Construction NTP: September 2023

- Anticipated Substantial Completion: [April 2025](#)



Open Projects: Construction

Interim Hubs, Phase 2

Improve lighting, landscaping and seating at interim hubs at Main Library and N.O. East Library

Contracting:

Design: GoTech (downtown) Infinity (N.O. East)

Construction: TEH

Project Budget:

Project: \$750,000

Schedule:

Construction Start: 12/4/24

Construction Completion: Downtown: **Substantially Complete**

March 2025 downtown mural/punchlist

Spring 2025 for N.O. East

Status:

Install Entergy meter to activate lighting

Punchlist downtown: utility box setting + concrete

Prepping for N.O. East improvements



Board Action:

None currently



Open Projects: Design

Algiers Ferry Buildings Renovation

Rehabilitate and modernize the 40-year-old Algiers Ferry Terminal for modern vessels and access, add Marine administrative offices, develop concessions/public space. Renovate Lower Algiers Maintenance Facility.

Contracting:

Engineer: Batture

Contractor: TBD

Contracting Strategy: D/B/B

Project Budget:

Total: \$9,861,000 (80% grant funded)

Schedule:

Design NTP: **January 2024**

Construction Bid Release: **March 2025**

Construction Start: July 2025

Substantial Completion: July 2026

Status:

Bid package complete; routing for release



Board Action:

None currently





Open Projects: Design

Algiers Ferry Barges Modernization

Replace landing barges at Algiers Point and Lower Algiers with new, standardized design for interoperability between ferry landing locations.

Contracting:

Engineer: Infinity Engineering (On-Call A&E)

Contractor: TBD

Contracting Strategy: D/B/B

Project Budget:

Total: \$13,670,000 (80% grant funded)

Schedule:

Design NTP: **November 2024**

Construction Bid Release: June 2025

Construction Start: September 2025

Substantial Completion: June 2026

Status:

30% Schematic Design due 3/17



Board Action:

None currently



Open Projects: Design

Zero Emission Bus Pilot

Purchase of three (3) electric buses and charging infrastructure. Engineering is included in the purchase.

Contracting:

Engineer: Kimley Horn

Contractor: New Flyer

Contracting Strategy: Named partner (turnkey)

Project Budget:

Total: \$6,324,288 (77% grant funded)

Schedule:

NTP for Bus Procurement: [October 2024](#)

Infrastructure Design 100% complete: June 2025

Construction NTP: September 2025

Electric Bus Roll Out: Spring - Fall 2026 (awaiting detailed bus delivery schedule)

Status:

[In-route charging site in N.O. East finalized; Resolved issues with CNO](#)
[Completed updated re-budget and issued updated PO to New Flyer](#)



Board Action:

None currently



Open Projects: Plans/Studies

Plan/Study	Scope	Status	Budget	Funding Source
Universal Accessibility Study	Roadmap for access to all RTA services regardless of ability, implementation plan and evaluation framework	Industry scan complete	\$250,000	Local (Operating)
Lo/No Implementation Planning	1) Evaluate program delivery options 2) Develop future fleet facility plan	Task 1 Complete Task 2 underway	\$180,000	Local (Operating)
Transit Stop Inventory Update & Assessment	Update transit stops inventory and ADA compliance; develop improvement program;	Finalizing inventory requirements	\$600,000	Local (Operating)



Open Projects: In Procurement

Name	Number	Solicitation	Status	Budget
Fare Modernization Initiative Consultant	2022-IT-02	RFQ for service related to: fare modernization plan; technology procurement; support implementation	Re-solicit required	NTE \$876,000
Climate-Adaptive Transit Shelter Design Services	2023-FA-04	RFQ for service related to: design and prototype Better Bus Stop shelter;	RFQ Closed: 12/19 Selection Cmte: TBD	NTE \$650,000
Streetcar System Modernization Master Plan	2025-PS-01	RFQ for services related to: streetcar system existing conditions; roadmap for accessibility, technology, fleet	Q&A: 3/7 Responses due: 3/21	\$1,000,000



Open Projects: In Development

Name	Number	Scope	Status	Budget
Carrollton Double Crossover Replacement	2019-FG-01	Installation of special trackwork at end of St Charles streetcar	Re-bid for April 2025	\$2,000,000
Program Management Services (BRT + CIP)	n/a	PM/CM Support for Capital Program	Finalizing funding Release 4/2025	On-call
Downtown Transit Center	2015-FA-01	100% Design	RFQ release 5/2025	\$33 million (total project)
BRT East-West Bank Corridor	2021-FG-01	30% Design and environmental	RFQ Release 4/2025	NTE \$4 million



Grants / Funding Request

Grant Program	Funding Request	Status	Federal Amount Awarded	Scope Request
Transit Oriented Development (TOD) Pilot Program	\$760,000 Fed \$190,000 RTA	Awarded	Full amount	Develop TOD land-use regulations, station area plans and opportunity sites along BRT
PROTECT	\$8,000,000 Fed \$2,000,000 RTA	NOFO Rescinded	n/a	Better-bus stop and shelter buildout



Questions?



Agenda

9. Five-Year Capital Improvement Plan

5-Year Capital Investment Program 2025-2029

25-027



5-Year Capital Investment Program (CIP) Overview



CIP Funding Sources by Year

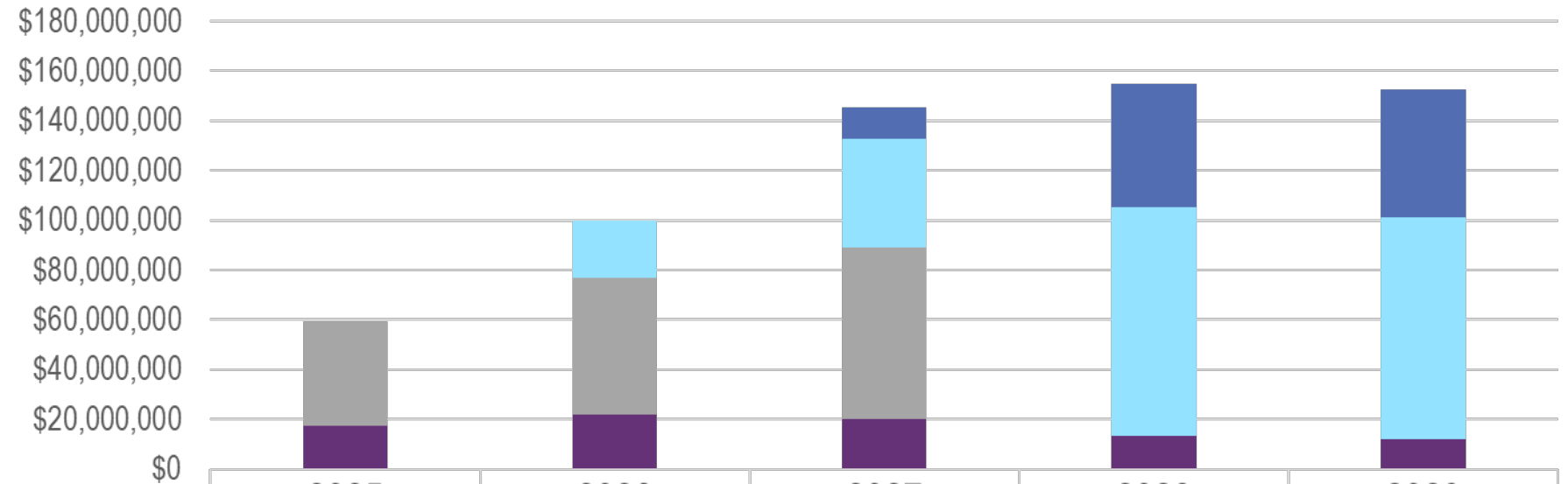

	2025	2026	2027	2028	2029
Proposed Bond Proceeds	\$0	\$0	\$12,805,914	\$49,571,278	\$51,122,808
Proposed Funding	\$0	\$23,235,753	\$43,755,375	\$92,110,750	\$89,110,750
Secured Awards	\$41,962,945	\$54,916,555	\$68,628,428	\$0	\$0
Local Funds	\$17,508,933	\$21,811,096	\$20,311,373	\$13,151,187	\$12,151,187

Notes:

1. All amounts in 2023 dollars and do not account for year of expenditure





Questions?



Agenda

10. Informational Report

2024 Annual Fare Report

25-025



Annual gross revenue, 2022-24

Point of Sale	2022	2023	2024	RY24 YOY Change
At Vehicle	\$ 6,971,477.70	\$ 6,596,894.58	\$ 5,920,461.43	-10.3%
TVM	\$ 1,648.85	\$ 40,889.95	\$ 70,804.85	73.2%
Mobile	\$ 2,792,509.75	\$ 3,727,997.40	\$ 4,525,239.95	21.4%
Admin	\$ 785,347.95	\$ 850,929.88	\$ 988,832.62	16.2%
Total	\$ 10,553,007.25	\$ 1,216,711.81	\$ 11,505,338.85	2.6%

Share of Annual Gross Revenue, by Source

Pre-paid sales (TVM, Mobile, Admin) nearly 50% of gross revenue in 2024

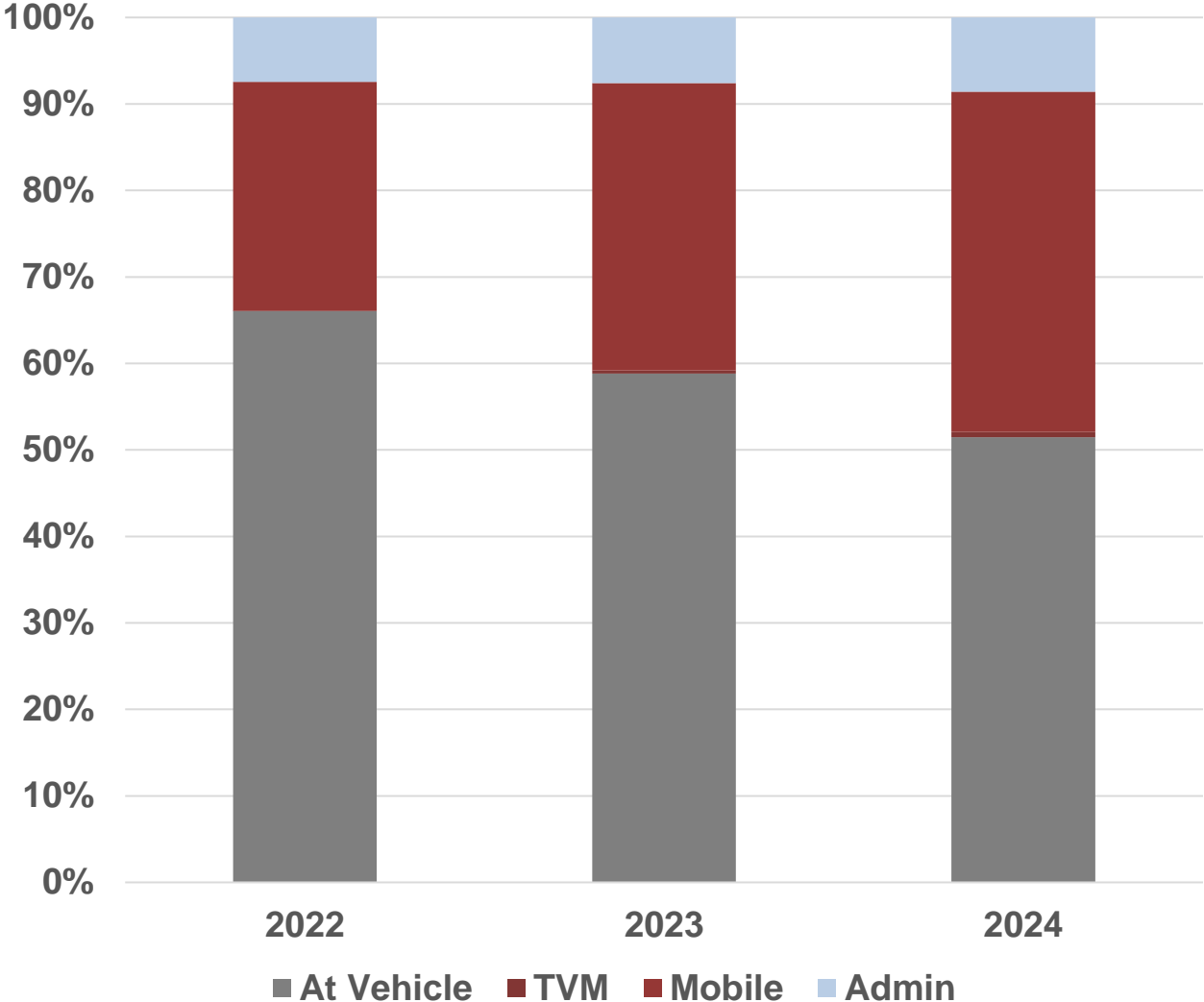



Total Sales by Product Type

	Adult	Priority Rider	Youth	Grand Total
Ferry Single Ride	98,915	4,522	6,858	110,295
Bus-SR Single Ride	3,485,561	248,804	178,544	3,912,909
Jazzy Pass	902,647	634,382	283,988	1,821,017
Opportunity Pass	31,992		14,575	46,567
Regional Ride	20,888	218	607	21,713
U-Pass	50			50
Grand Total	4,540,053	887,926	484,572	5,912,551

Transit Access Purchased (Days)

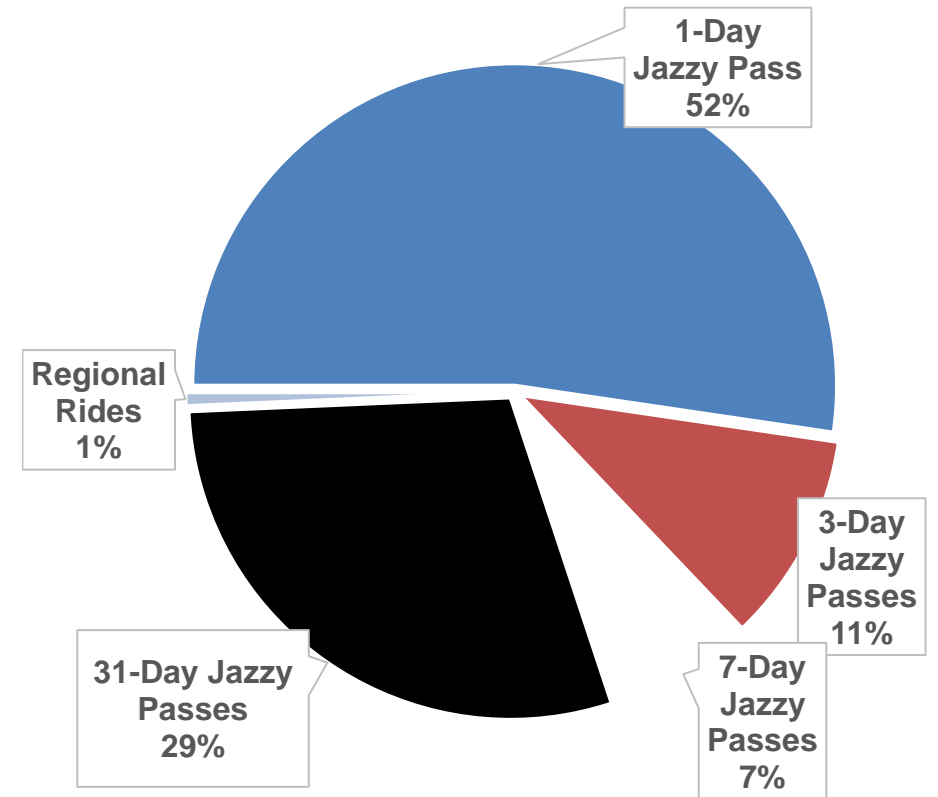



Questions?



Agenda

11. Procurements

A. Authorizations:

Purchase of Canal and Riverfront Streetcar Tires	25-022
Outside Counsel Legal Services	25-024
RTA Insurance Brokerage Services for Property and Casualty Coverages	25-028

B. Amendments:

Change Order Request – Carr Riggs, & Ingram Contract (RFQ 2019-021)	25-023
--	--------



Agenda

12. New Business



Agenda

13. Audience Questions & Comments



Agenda

14. Adjournment